

UNIT 3

FLOWING WELL PROBLEMS

1. The lease operator is expected to maintain production from all _____ assigned to him.
2. Some wells flow naturally; others are produced by pumps or gas lift.

All wells are operated to maintain production at or near the _____ set for the well while conserving the formation's _____ as much as possible.

3. As long as all wells are producing normally, total production from a lease is about the same from day to day.

The operator measures the total _____ from the lease at regular intervals.

4. He keeps accurate _____ of production.
5. The volume of produced fluid is measured by a gage line or automatic gages at the _____ tank.
6. Or, the fluid output may be *metered* to show the total _____ produced.

OVERPRODUCTION AND UNDERPRODUCTION

7. When the volume of produced fluids suddenly *increases*, one or more wells may be (overproducing/underproducing).
8. Overproduction is more likely to be a problem in a (flowing/pumping or gas lift) well.
9. If the total volume of produced fluid falls, one or more wells is (overproducing/underproducing).
10. The operator must find the well and its problem, and _____ it if he can.
11. He reports the conditions at the well to his _____.

12. Accurate records are kept of changes made at each well.

If the operator repairs a leaking line or installs a different size choke, he puts this change on his _____.

13. As long as production from the lease is steady, the operator does not need to inspect each _____ on the lease.

14. When a problem develops, he must find it, _____ it if he can, report the condition to his _____, and keep accurate _____ on all changes made at the well.

Symptoms at the Well

15. Well-head pressures are steady when the well is flowing steadily.

Tubing pressures are indicated on the _____ pressure gage.

16. Pressures in the annulus are shown on the _____ pressure gage.

17. A flow-line pressure gage may be set downstream from the choke.

This gage shows _____-_____ pressure.

18. When there is a packer in the well, (tubing/casing) pressure should not change in the flowing life of the well.

19. Well records will show whether or not there is a _____ in the well.

20. Well-head gages are accurate only to the nearest 10 to 25 PSIG.

A change of 5 PSIG in tubing or casing pressure probably (will/will not) be noticed.

21. The operator keeps continuous records of the tubing and casing pressures at each well.

When he finds well-head pressures suddenly changing, he has probably found a well that is either overproducing or _____.

22. A surface choke maintains *back pressure* on the tubing.

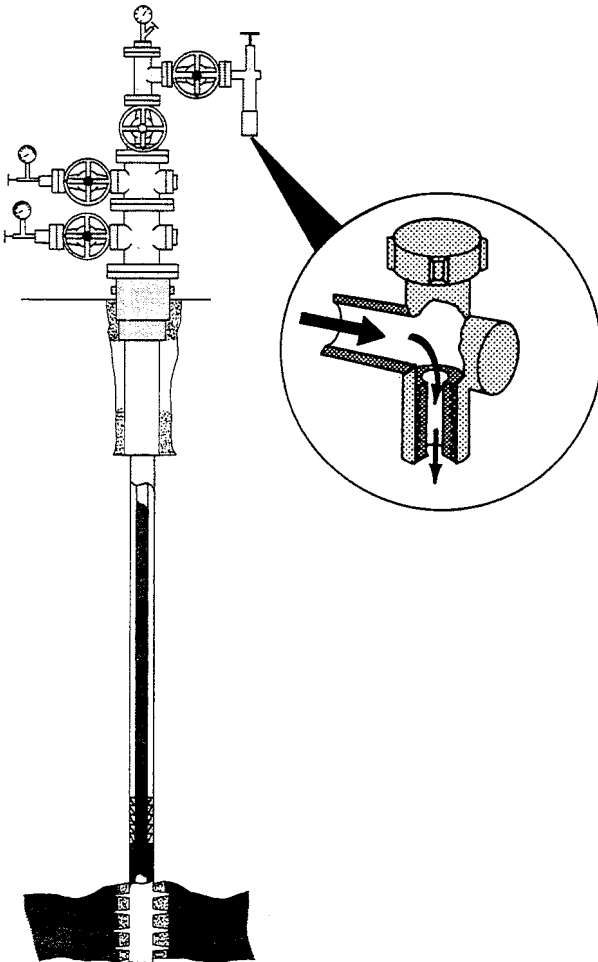

During normal operation, the tubing pressure gage reading is (higher/lower) because of the effect of the surface choke.

23. Suppose the surface choke becomes worn or eroded.

Flow through the choke (increases/decreases), and the well may begin (overproducing/underproducing).

24. The tubing pressure *upstream* from an eroded choke (rises/falls).

25. Tubing pressures (increase/decrease) when a well is overproducing because of an eroded surface choke.

26. Suppose a surface choke is plugged with solid deposits from the fluid.

Flow through the choke (increases/decreases), and the well may begin (overproducing/underproducing).

27. A plugged choke creates a higher back pressure *upstream* from the choke.

Tubing pressures (increase/decrease) when a surface choke is plugged.

28. When a well is *overproducing* because of an eroded surface choke, tubing pressure (increases/decreases).

29. When a well is *underproducing* because of a plugged surface choke, tubing pressure (increases/decreases).

30. Erosion and plugging of subsurface chokes have the opposite effect on tubing pressures.

An eroded subsurface choke will cause tubing pressure to (rise/fall).

31. A plugged subsurface choke will cause tubing pressure to (increase/decrease).

32. Underproduction is indicated by a *rise* in tubing pressure if a (surface/subsurface) choke or pipe is plugged (upstream/downstream) from the tubing pressure gage.

33. Underproduction caused by a plugged subsurface choke or by deposits in the tubing is indicated by a (rise/fall) in tubing pressure.

34. Overproduction is accompanied by a rising tubing pressure when a (surface/subsurface) choke is eroded, and by a falling tubing pressure when a (surface/subsurface) choke is eroded.

35. Besides changing pressures, changes in flowing-well production may also be indicated by changing *sounds* at the well head.

A *hissing* sound in the pipes may indicate that more (gas/oil) is being produced, and that the GOR is (rising/falling).

36. When a well is beginning to head, less fluid reaches the storage tank.

Heading causes (underproduction/overproduction).

37. Heading causes a change in the _____ the fluid makes as it flows through the line.

38. Changes in the temperature at the oil field can also affect the volume of fluid that reaches the storage tank.

Cold weather may cause solids to freeze and plug the surface lines.

Low temperatures at the field may cause (overproduction/underproduction).

39. High temperatures temporarily may cause *overproduction*.

Gas expands when temperatures (increase/decrease).

40. In very hot weather, expanding gas in the surface lines may purge the lines of liquids.

Gas expansion in the lines forces (more/less) liquid into the tank battery.

41. The first effect of gas expansion in the surface lines may be (overproduction/underproduction).

42. But when the gas has purged the lines of liquid, the gages at the tanks will begin to show a (rise/fall) in production.

43. If production from a lease is rising or falling, the operator needs to inspect each well for *changes* or *symptoms* that will help him pinpoint the problem.

One of the main symptoms that can be observed at the well head is a change in tubing or casing _____.

44. Another symptom is a change in the _____ the fluid makes as it flows from the well.

45. Not all production changes are caused by changes at the well.

If a surface vessel is malfunctioning, this could cause a _____ in the measured or metered production at the tanks.

46. If the weather turns hot or cold, this (can/cannot) affect flow through the surface lines.

47. In inspecting each well on an underproducing or overproducing lease, the operator needs to look for changes in _____ and temperature, and listen for changes in _____.

48. He needs to consider whether the problem is caused by changes at the well, or whether the problem is in the _____ equipment and flow lines.

49. If the problem is at the well, the operator tries to pinpoint it still further.

If the problem is in a surface choke or valve, the operator may be able to repair it himself.

A well-service crew will probably need to be called if the problem is in (surface/subsurface) equipment.

Some Causes of Overproduction

50. When the total volume produced increases, one or more wells is _____.

51. The lease operator inspects each well to locate the one that is _____.

52. Overproduction is often caused by eroded _____.

53. An eroded surface choke is indicated by a (rise/drop) in tubing pressure.

54. An eroded adjustable choke may be pinched down to a _____ setting if the well is overproducing.

55. On a positive choke, a badly eroded flow bean or insert must usually be _____.
56. After replacing an eroded surface choke with a new choke of the same size, the operator checks production again in a day or two.
- If the well is still overproducing, a (larger/smaller) choke size may be needed.
57. After flowing tubing pressure is steady again, the operator may consult the choke selection _____ to find the size needed for the allowable at the well.
58. Sometimes overproduction is caused by an eroded *bottom-hole* _____ or regulator.
59. An eroded bottom-hole choke is indicated by a _____ in tubing pressure.
60. The operator reports changing down-hole conditions to his _____.
61. Overproduction caused by an eroded bottom-hole choke may be temporarily reduced by installing a smaller size choke at the _____.
62. Eventually, a wireline crew will be needed to replace a (surface/bottom-hole) choke.
63. Suppose a flowing well is produced alternately from two reservoirs.
- The allowable for the well is (more/less) than the total that could flow if both reservoirs were produced at the same time.
64. Overproduction may be caused by a _____ from the reservoir that is not being produced.
65. *Unplanned communications* are leaks between different flow paths in a _____-completion well.
66. A worn tubing plug, separating tool, or side door choke may cause unplanned _____.

67. A packer with worn seals or an unseated packer can also cause _____ communications.
68. If the operator suspects overproduction from unplanned communication, he may need to _____ the well while a wireline crew is being called.
69. Sometimes the problem cannot be solved by wireline operations.
- If the problem is in tubing-run equipment, the well will need to be _____ before the equipment can be pulled for repairs.
70. If the problem is leaking tubing, the well will need to be _____ for repairs.
71. The operator can consult his _____ to find the equipment set in the well.
72. If the communication equipment is wireline-run, the problem can usually be solved by calling a _____ crew.
73. If the equipment is tubing-run, a service crew will need to be called in to _____ the well and repair the equipment.
74. Overproduction is usually caused by:
- an eroded or worn _____ at the surface or in the tubing; or by
- unplanned communication with fluid from a (higher/lower) pressure reservoir.
75. The lease operator adjusts or replaces a worn _____ choke himself.
76. He reports an eroded bottom-hole choke to his foreman, and either a _____ crew or a service crew is called in to repair the equipment.
77. The operator studies the _____ kept on the well to help pinpoint the trouble.

Some Causes of Underproduction

78. Underproduction from a plugged surface choke or from plugged surface lines shows at the well head as a (rise/drop) in tubing pressure.
79. A plugged bottom-hole choke causes tubing pressures to (rise/drop).
80. If flow from the well has stopped altogether, a safety _____ may have shut in the well.
81. If the tubing pressure gage has fallen to zero, this would mean a (surface safety valve/storm choke) has shut in the well.
82. Surface safety valves may shut in the well because of:
high or low flow-line _____; or
high or low fluid _____; or
too _____ or too _____ a rate; or
too _____ or too _____ a level in a surface vessel.
83. If a high-pressure, rate, or level pilot has triggered the valve, the problem at the well is probably not underproduction.
The problem is probably _____ production.
84. Before resetting a surface safety valve and reopening the well, the operator needs to know why the valve was triggered.
If the reason for the high or low pressure or temperature is not found and corrected, the safety valve will soon _____ the well again.
85. If a low-pressure pilot has triggered the valve, the problem probably (is/is not) underproduction.
86. Hydrates, paraffin, and other solids may wholly or partially _____ the flow path in a well.
87. Plugging may result in (underproduction/overproduction).

88. One of the first things the operator looks for in an under-producing well is _____ in the line.

89. Paraffins tend to deposit out anywhere in the flow line or tubing.

Usually, the operator will know if the oil in his wells is likely to deposit much _____.

90. Sometimes, balls or other devices are injected into surface flow lines to remove paraffin.

The flowing fluid carries the ball or plug through the line to the place where it is ejected.

The rolling ball or plug helps remove the _____ from the flow pipe.

91. Scrapers are run into the _____ on a wire line to remove paraffin.

92. If paraffin seems to be blocking the tubing, a _____ crew may need to be called.

93. Sometimes, the tubing pressure gage reading can be used to locate plugs in the line.

If the plugs are in the tubing, tubing pressure will be _____.

94. If the plugs are *downstream* from the tubing pressure gage, the gage reading will be _____.

95. A plugged surface choke causes tubing pressure to _____.

96. Plugged surface chokes may be removed from the line and _____ out by the operator.

97. Solids such as paraffin and hydrates deposit out when pressure drops cool the fluid.

One way of preventing hydrates from depositing is to _____ the fluid at the choke.

98. Another way to prevent deposits is to use subsurface chokes, so that the pressure drop occurs deep in the well-bore where temperatures are _____.

99. Or, *solvents* may be injected into the well-bore to lower the freezing point of the fluid.

It takes a (higher/lower) pressure drop for solids to form when solvents are used.

100. Flow-line heaters, regular scraping of tubing and cleaning of surface lines, and solvent injections are all forms of *preventive maintenance*.

Preventive maintenance is solving problems (before/after) they occur.

101. Preventive maintenance includes removing plugs *before* they cause _____.

102. Some companies have regular schedules set up for preventive maintenance at flowing wells.

Others expect the operator to set up his own preventive maintenance _____.

103. In *inhibition* programs, solvents under pressure are injected regularly into the tubing, annulus, or surface lines.

Inhibition programs are a form of _____ maintenance.

104. The amount of solvent or inhibitor injected must be carefully controlled.

The operator should follow technical personnel's or manufacturer's _____ carefully in all preventive maintenance procedures.

105. To be effective, preventive maintenance schedules must be _____ carefully.

106. Plastic-coated tubing may help prevent solid deposits from sticking to the tubing.

Using plastic-coated tubing is another form of _____ maintenance.

107. *Sand* in the well-bore cannot be dissolved.

Sand is carried into the well-bore from the _____.

108. Sand bridges a hundred feet long may plug the tubing.

Removing a sand bridge is a job for the _____ crew.

109. Less sand is washed into the well if the flow rate at the sand face is (higher/lower).

110. Bottom-hole flow rates can be controlled by the use of _____.

111. The best preventive maintenance for sand plugs is probably a carefully selected flow rate.

The choke size used must produce the desired _____ of flow to prevent sand bridges from forming.

112. Paraffin, hydrates, scale, and sand are major causes of (underproduction/overproduction).

113. Suppose fluid is leaking through the casing to a non-productive formation.

The fluid that leaves the well-bore through a casing leak (can/cannot) be recovered again.

114. Unplanned _____ can also cause underproduction.

115. If a well being produced through the annulus begins underproducing, the operator may suspect a casing _____.

116. In a multiple-completion well, the problem may also be a *tubing* leak.

High-pressure fluid leaking from the annulus to the tubing would cause the line from the annulus to show (overproduction/underproduction).

117. At the same time, the line from the tubing would show _____ production.

118. Usually, the higher-pressure well is produced through tubing.

Usually, a tubing leak causes flow (into/out of) the tubing, and production from the annulus is (increased/decreased) by a tubing leak.

119. If a corrosive fluid is leaking from the tubing, the well may need to be _____ immediately to protect the casing.

120. Underproduction may also be caused by a damaged packer.

Fluid may leak around the packer either into or out of the casing, depending on the _____ of the fluids.

121. Usually, unplanned communication in a multiple-completion well does not noticeably affect total production.

Since the leaking fluid is produced from the other flow line, total production (increases/decreases/remains the same).

122. For this reason, especially careful records are kept of the various flow-line and tubing _____ in a multiple-completion well.

123. An increase in one set of pressures and a decrease in another probably means there is an unplanned _____ in the well-bore.

124. In a single-completion well without a packer, unplanned tubing-annulus communication is hard to detect.

Until well-bore pressures equalize, the flow rate and tubing pressure will (rise/drop) slightly when there is a tubing leak.

125. Then, when tubing-annulus pressures equalize, production becomes _____ again.

126. In wells with a packer, leaks into the annulus show as an increase in _____ pressure.

Review

127. Overproduction is usually caused either by worn _____ or by unplanned communication with a (higher/lower) -pressure fluid.
128. *Underproduction* may be caused by _____ in the line or by unplanned communication with a _____ -pressure fluid.
129. Underproduction may also be caused by an increase in the density of the flowing fluid, which causes (an increase/a decrease) in hydrostatic BHP.
130. Or underproduction may be a sign that reservoir pressure is (increasing/decreasing).
131. Prompt replacement of eroded chokes helps prevent _____.
132. Preventive maintenance and inhibition programs prevent plugs from _____ in the line.
133. Sometimes a safety valve shuts in the well.
The operator must find the _____ that triggered the valve.
134. Surface safety valves are fail-safe valves.
The valve may have shut in the well because the _____ itself is damaged.
135. Or a high-low pilot may shut in the well because of either _____ production or _____ production.
136. Underproduction may also be caused by heading.
When a well begins to produce by heads, total production from the well usually _____.
137. A heading well may be stop-cocked, or an intermitter may be installed to maintain production closer to the _____ for the well.