



# Individual Development Plan CNC Pathway

Name: \_\_\_\_\_

College: \_\_\_\_\_

Date: \_\_\_\_\_

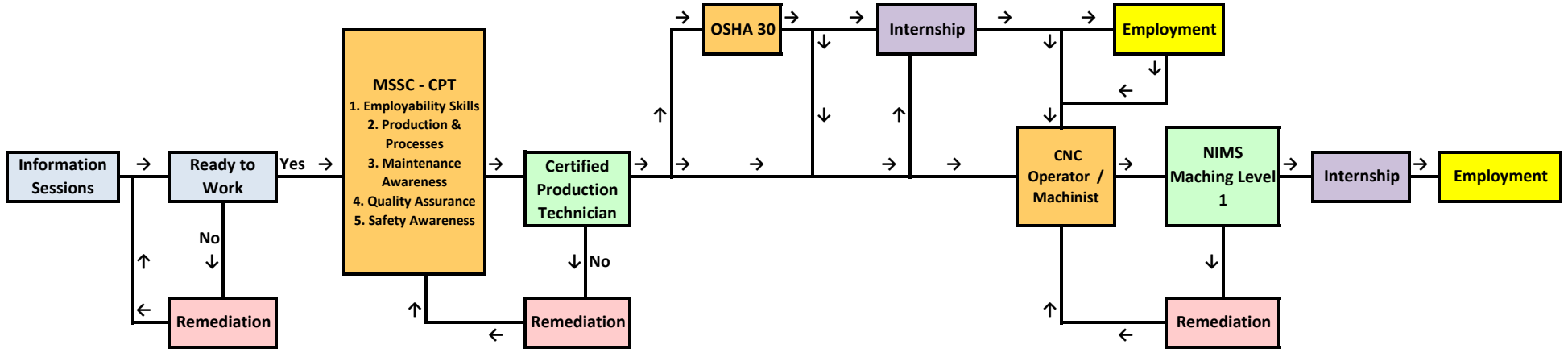

Task/Activity/Course	Date Completed/Achieved
Information Session	
Ready to Work Credential	
Intro to Manufacturing	
<b>MSSC Start Date</b>	
Safety Awareness	
Maintenance Awareness	
Production and Processes	
Quality Awareness	
Employability Skills	
CPT Certification	

Task/Activity/Course	Date Completed/Achieved
<b>OSHA Training</b>	
<b>CNC Training</b>	
<b>NIMS Maching Level 1</b>	

**Internship:**  
 Company: \_\_\_\_\_  
 Start Date: \_\_\_\_\_  
 End Date: \_\_\_\_\_  
 Pay: \_\_\_\_\_

**Employment:**  
 Company: \_\_\_\_\_  
 Start Date: \_\_\_\_\_  
 Start Pay: \_\_\_\_\_  
 6 Month Pay: \_\_\_\_\_

Comments / Follow Up (Use Back if Needed)