

# Factors Affecting Drug Activity

# Chapter Objectives

- List physiological factors that influence drugs and may lead to an altered response
- Describe how common disease states can lead to an altered drug response
- Understand common ADRs and how they can occur in one person but not others
- Understand drug-drug interactions that impact the drug at the site of action
- Describe how drug-drug interactions may alter drug disposition

# Chapter Outline

- Human Variability
- Disease States
- Adverse Drug Reactions
- Drug-Drug Interactions
- Drug-Diet Interactions

# Human Variability – Age

- Overall, metabolism declines with age.
- Neonates and infants
  - Drug distribution, metabolism, and excretion slower.
- Children (age range from 1-12 yr old.)
  - Metabolize certain drugs more rapidly, e.g. clindamycin, valproic acid, ethosuximide and theophylline.

# Human Variability – Age

- The elderly
  - Consume more drugs.
  - Changes in gastric emptying, slow circulation, decline in liver and kidney functions.

# Human Variability

- Gender
  - Women and men handle some drugs differently.
    - Propranolol, isosorbide, diazepam, temazepam, Tylenol
- Body composition and drug distribution

# Human Variability

- Pregnancy
  - Delayed gastric emptying, slow GI transit.
  - Risk of fetal exposure
- Genetics
  - Determines type and amounts of proteins produced in the body.

# Human Variability

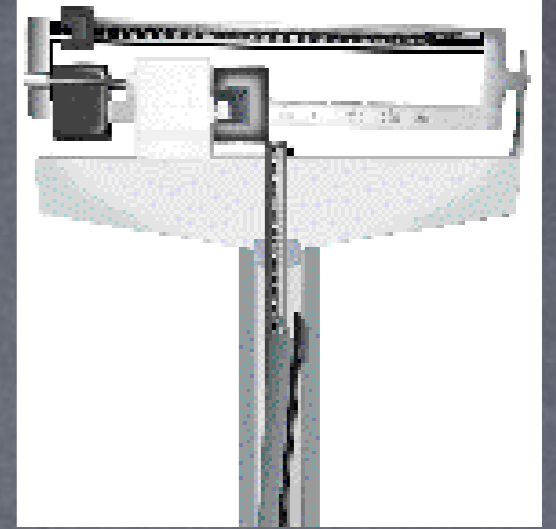

- Pharmacogenetics
  - Defines the hereditary basis of individual differences in the ADME process.
- Body weight
  - Important in dosing medication to children.
- Psychological factors
  - Influences patients responses to drugs, e.g. placebo effect.



# Diseases that affect drug disposition

- The disposition and effect of some drugs can be influenced by the presence of disease.
- Cirrhosis
  - A chronic diseases that occurs with long term alcohol abuse.

# Diseases that affect drug disposition

- Acute viral hepatitis
  - An inflammatory condition of the liver caused by viruses.
- Obstructive jaundice
  - Obstruction of the bile duct causing hepatic waste products and bile to accumulate in the liver.

# Renal Diseases

- Reduced renal function can affect the elimination of many drugs.
- As renal function decreases, the dosage of a drug that is eliminated by the kidney should be reduced.
- Decrease in renal function is measured by the amount of creatinine in the blood.

# Thyroid Disease

- Changes in thyroid function affect the disposition of many drugs.
- Hypothyroidism increases the bioavailability of digoxin, riboflavin.
- Hyperthyroidism causes increased metabolism of theophylline, propranolol, propylthiouracil, & methimazole.

# Adverse Drug Reactions

- Drugs have a mixture of two effects .
  - Therapeutic (desired)
  - Adverse effects (undesired effects)
- Adverse Drug Event (Side effects)
  - Harm caused by the drug.
  - Adverse Drug Reaction
  - Harm directly caused by the drug at normal doses.

# Adverse Drug Reactions

- Medication Error
  - Inappropriate use of a drug.

# Common Adverse Drug Reactions

- **Central Nervous System Effects**
  - CNS stimulation: agitation, confusion, disorientation.
  - CNS Depression: dizziness, drowsiness, sedation, coma.
- **Idiosyncrasy** -Unexpected reaction to a drug.

# Common Adverse Drug Reactions

- Hepatotoxic
  - Occurs with acetaminophen, isoniazide, nitrofurantoin.
- Nephrotoxic
  - Occurs with aminoglycosides, nonsteroidal anti-inflammatory drugs.



# Hypersensitive or Allergy

- Any drug can produce an allergic reaction.
- Involves
  - Antibodies antigen reaction
    - Previous sensitization with a drug or a similar drug required.
- The reaction causes the release of histamine that leads to rash, itching, and in severe cases difficulty of breathing and even death.
- Anaphylactic shock - potentially fatal type of reaction and can occur within minutes.

# Common Adverse Drug Reactions

- Gastrointestinal effects
- Occur with nonsteroidal anti-inflammatory drugs (aspirin).
- Drug dependence
- Causes withdrawal effect upon discontinuation.
- Results from chronic use of narcotic analgesics.
- Teratogenicity
- Substance causing abnormal fetal development.
- Hematological effect
- Blood coagulation, bleeding, and bone marrow disorder.
- Carcinogenicity
- Cancer causing drugs.

# Drug-Drug Interactions

- Definition:
- Administration of more than one drug at a time.
- Results in an increase or decrease of the therapeutic effects.
- Time of reaction varies.
- Enzymes involved in the metabolism of drugs primarily occur in the liver.

# Drug-Drug Interactions

- Additive Effects
- Occurs when two drugs result in an effect equal to the sum of the individual effects.
  - Vytorin - combination of Zocor and Zetia.

# Drug-Drug Interactions

- Potentiation
- Occurs when one drug with no inherent activity of its own increases the activity of another drug that produces an effect.
- carbidopa + dopa = prolonged action and longer duration of action for Parkinson's disease.

# Drug-Drug Interactions

- Synergism
- Occurs when two drugs with similar pharmacological actions produce greater effects than the sum of individual effects.
  - Trimethoprim + sulfamethoxazole (Bactrim) for antibiotic effect.
  - penicillin + vancomycin = increased antibacterial effects.

# Drug-Drug Interactions

- Antidote
  - A particular drug given to block or reduce the toxic effect of another drug.
  - Vitamin K reverses the effect of warfarin (blood thinner medicine).
  - Naloxone + morphine reverses the effect of morphine or other narcotics.

# Drug-Drug Interactions

- Chelating
- Drug binds with another drug forming a complex which reduces absorption
- Aluminum or magnesium hydroxide (antacid) + tetracycline inhibits the antibiotic effect of TCN.
- Cholestyramine + thyroxine binding of thyroxin reducing its absorption.



# Drug-Drug Interactions

- Displacement
  - One drug from a protein binding site is replaced by another drug.
  - Aspirin + warfarin = increased effect of warfarin.
- Inhibition
  - One drug inhibits the breakdown of another agent
  - Cimetidine inhibits the breakdown of digoxin causing digoxin toxicity.
- Induction
  - One drug increases an enzyme.
- Pharmacogenetics
  - Effect of a gene on drug disposition.

# Drug-Drug Interaction

- Induction: One drug increases the metabolizing enzyme that breaks down another drug.
- Phenytoin + oral contraceptives = decreased contraception effect.

# Drug-Drug Interaction

- Urinary excretion: Drugs altering the urinary pH that cause a decrease in renal reabsorption.
  - Sodium bicarbonate + Phenobarbital = increased excretion of Phenobarbital.
  - Quinidine + digoxin = digoxin excretion is reduced by 30-50%.

# Drug-Diet Interaction

- When elements of ingested nutrients interact with a drug affecting the disposition of the drug.
- Absorption
- TCN+ Iron = decreases TCN absorption.
- Phenytoin + food = increased absorption.
- Interactions that alter absorption with food or nutrient can be avoided by separating the administration of drugs and food intake by about 2 hours.

# Drug-Diet Interaction

- Specific food
- Cruciferous vegetables like cabbage and brussels sprouts may stimulate the metabolism of some drugs.
- Spinach and other green vegetables contain vitamin K and inhibit the action of warfarin.
- Tyramine containing food + monoamine oxidase (MAO) inhibitors = severe hypertension or intracranial hemorrhage.

# Terms to Remember

1. Acute viral hepatitis
2. Additive effects
3. Adverse drug reaction
4. Anaphylactic shock
5. Antidote
6. Carcinogenicity
7. Cirrhosis
8. Complexation
9. Displacement
10. Drug–diet interactions
11. Enzyme induction
12. Enzyme inhibition
13. Hypersensitivity
14. Hyperthyroidism
15. Hypothyroidism
16. Idiosyncrasy
17. Obstructive jaundice
18. Pharmacogenetics
19. Potentiation
20. Synergism

*This work is licensed under a Creative Commons 3.0 License <http://creativecommons.org/licenses/by/3.0>*



*This workforce solution is 100% funded by a grant awarded by the U.S. Department of Labor, Employment and Training Administration, TAACCCT grant agreement # TC-22505-11-60-A-25. The solution was created by the grantee and does not necessarily reflect the official position of the U.S. Department of Labor. The Department of Labor makes no guarantees, warranties, or assurances of any kind, express or implied, with respect to such information, including any information on linked sites and including, but not limited to, accuracy of the information or its completeness, timeliness, usefulness, adequacy, continued availability, or ownership. Massachusetts Community Colleges are equal opportunity employers. Adaptive equipment available upon request for persons with disabilities.*