

Air Washington Electronics – Direct Current

Contents

| | |
|--|----|
| 7 Voltage and Current Dividers..... | 1 |
| Voltage Dividers | 4 |
| Media Resources | 8 |
| Knowledge Check | 8 |
| Multiple-Load Voltage Dividers | 9 |
| Knowledge Check | 13 |
| Power in the Voltage Divider | 14 |
| Voltage Divider with Positive & Negative Voltage Requirements..... | 16 |
| Knowledge Check | 19 |
| Practical Application of Voltage Dividers..... | 20 |
| Knowledge Check | 24 |
| Voltage Divider Circuits..... | 24 |
| Media Resources | 29 |
| Knowledge Check..... | 29 |
| Potentiometer as Voltage Divider..... | 29 |
| Current divider circuits | 34 |
| Media Resources | 39 |
| 1: Voltage Divider Circuit | 40 |
| Components & Equipment Needed | 40 |
| Circuit Diagram..... | 40 |
| Procedure | 40 |
| Table for Voltage Divider Circuit Lab..... | 41 |
| Observations & Conclusions..... | 41 |
| 2: Designing a Loaded Voltage Divider | 42 |
| Components & Equipment Needed | 42 |
| Procedure | 42 |

Air Washington Electronics – Direct Current

| | |
|---|----|
| Table for Designing a Loaded Voltage Divider Circuit Lab | 43 |
| Observations & Conclusions..... | 43 |
| 3: Critical Thinking..... | 44 |
| Answers to Knowledge Checks | 45 |
| Voltage Dividers | 45 |
| Multiple-Load Voltage Dividers..... | 46 |
| Voltage Divider with Positive & Negative Voltage Requirements | 47 |
| Practical Application of Voltage Dividers | 48 |
| Additional Resources | 49 |
| Physics Resources..... | 49 |
| Video Resources | 49 |
| References | 50 |
| Attributions | 51 |
| Table of Figures..... | 52 |
| Table of Tables | 53 |

Voltage Dividers

Most electrical and electronics equipment use voltages of various levels throughout their circuitry. One circuit may require a 90-volt supply, another a 150-volt supply, and still another a 180-volt supply. These voltage requirements could be supplied by three individual power sources. This method is expensive and requires a considerable amount of room. The most common method of supplying these voltages is to use a single voltage source and a **voltage divider**. Before voltage dividers are explained, a review of voltage references may be of help.

Recall that some circuits are designed to supply both positive and negative voltages. You may wonder if a negative voltage has any less potential than a positive voltage. The answer is that 100 volts is 100 volts. Whether it is negative or positive does not affect the feeling you get when you are shocked.

Voltage polarities are considered as being positive or negative in respect to a reference point, usually ground. Figure 1 will help to illustrate this point.

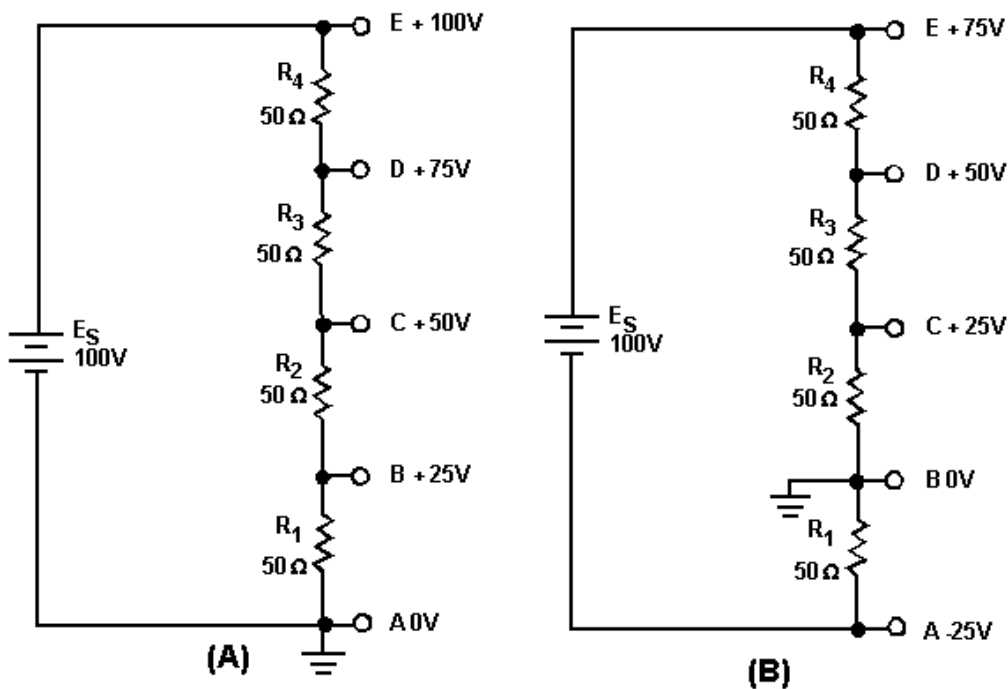

Figure 1: Voltage polarities.

Figure 1(A) shows a series circuit with a voltage source of 100 volts and four 50-ohm resistors connected in series. The ground, or reference point, is connected to one end of resistor R_1 . The current in this circuit determined by Ohm's law is 0.5 amp. Each resistor develops (drops) 25 volts. The five tap-off points indicated in the schematic are points at which the voltage can be measured. As indicated on the schematic, the voltage measured at each of the points from point A to point E starts at zero volts and becomes more positive in 25 volt steps to a value of positive 100 volts.

In Figure 1(B), the ground, or reference point has been moved to point B. The current in the circuit is still 0.5 amp and each resistor still develops 25 volts. The total voltage developed in the circuit remains at 100 volts, but because the reference point has been changed, the voltage at point A is negative 25 volts. Point E, which was at positive 100 volts in Figure 1(A), now has a voltage of positive 75 volts. As you can see the voltage at any point in the circuit is dependent on three factors: current through the resistor, ohmic value of the resistor, and reference point in the circuit.

A typical voltage divider consists of two or more resistors connected in series across a source voltage (E_s). The source voltage must be as high or higher than any voltage developed by the voltage divider. As the source voltage is dropped in successive steps through the series resistors, any desired portion of the source voltage may be "tapped off" to supply individual voltage requirements. The values of the series resistors used in the voltage divider are determined by the voltage and current requirements of the loads.

Figure 2 is used to illustrate the development of a simple voltage divider. The requirement for this voltage divider is to provide a voltage of 25 volts and a current of 910 milliamps to the load from a source voltage of 100 volts. Figure 2(A) provides a circuit in which 25 volts is available at point B. If the load was connected between point B and ground, you might think that the load would be supplied with 25 volts. This is not true since the load connected between point B and ground forms a parallel network of the load and resistor R_1 . (Remember that the value of resistance of a parallel network is always less than the value of the smallest resistor in the network.)

Air Washington Electronics – Direct Current

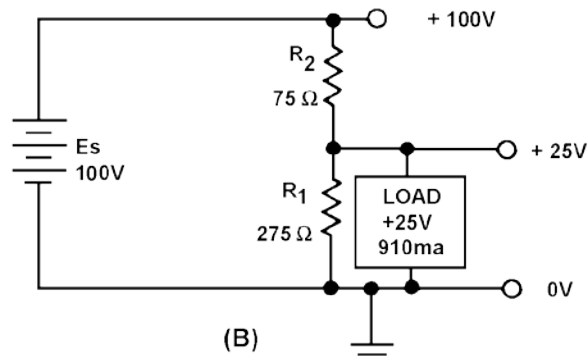
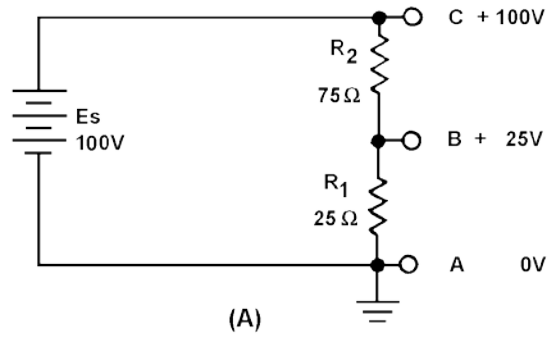

Since the resistance of the network would now be less than 25 ohms, the voltage at point B would be less than 25 volts. This would not satisfy the requirement of the load.

To determine the size of resistor used in the voltage divider, a rule-of-thumb is used. The current in the divider resistor should equal approximately 10% of the load current. This current, which does not flow through any of the load devices, is called **bleeder current**.

Given this information, the voltage divider can be designed using the following steps:

Determine the load requirement and the available voltage source.

$$\begin{aligned}E_s &= 100V \\E_{load} &= 25V \\I_{load} &= 910mA\end{aligned}$$

Select bleeder current by applying the 10% rule-of-thumb.

$$\begin{aligned}I_{R1} &= 10\% \times I_{load} \\I_{R1} &= .1 \times 910\text{mA} \\I_{R1} &= 91\text{mA}\end{aligned}$$

Calculate bleeder resistance.

$$\begin{aligned}R_1 &= \frac{E_{R1}}{I_{R1}} \\R_1 &= \frac{25\text{V}}{91\text{mA}} \\R_1 &= 274.73\Omega\end{aligned}$$

The value of R_1 may be rounded off to 275 ohms:

$$R_1 = 275\Omega$$

Calculate the total current (load plus bleeder).

$$\begin{aligned}I_T &= I_{load} + I_{R1} \\I_T &= 910\text{mA} + 91\text{mA} \\I_T &= 1\text{A (rounded off)}\end{aligned}$$

Calculate the resistance of the other divider resistor(s).

$$\begin{aligned}E_{R2} &= E_s - E_{R1} \\E_{R2} &= 100\text{V} - 25\text{V} \\E_{R2} &= 75\text{V} \\R_2 &= \frac{E_{R2}}{I_T} \\R_2 &= \frac{75\text{V}}{1\text{A}} \\R_2 &= 75\Omega\end{aligned}$$

The voltage divider circuit can now be drawn as shown in Figure 2(B).

Media Resources

Internet Archive - FEDFLIX

- Loaded Voltage Dividers (January 1, 1974)
 - <https://archive.org/details/gov.dod.dimoc.39981>

Wisc-Online.com

- [Voltage Dividers](#)

Knowledge Check

1. What information must be known to determine the component values for a voltage divider?
2. If a voltage divider is required for a load that will use 450 mA of current, what should be the value of bleeder current?
3. If the load in question 50 requires a voltage of +90 V, what should be the value of the bleeder resistor?
4. If the source voltage for the voltage divider in question 50 supplies 150 volts, what is the total current through the voltage divider?
5. A voltage divider is required to supply a single load with +150 V and 300 mA. The source voltage is 250 V. Based on this information, answer the following questions. (Hint: Draw the circuit).
 - A. What should be the value of the bleeder current?
 - a) 3 A
 - b) 300 mA
 - c) 30 mA
 - d) 3 mA
 - B. What should be the ohmic value of the bleeder resistor?
 - a) 50
 - b) 500
 - c) 5 k
 - d) 50 k

C. What is the value of total current?

- a) 303 mA
- b) 330 mA
- c) 600 mA
- d) 3300 mA

Multiple-Load Voltage Dividers

A multiple-load voltage divider is shown in Figure 3. An important point that was not emphasized before is that when using the 10% rule-of-thumb to calculate the bleeder current, you must take 10% of the total load current.

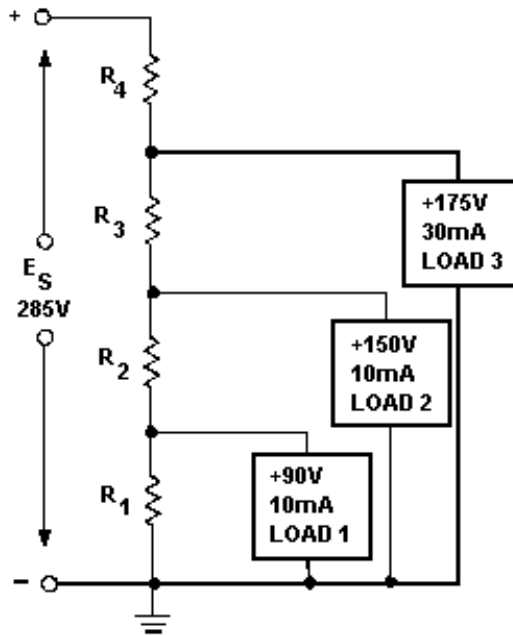

Figure 3: Multiple-load voltage divider.

Given the information shown in Figure 3, you can calculate the values for the resistors needed in the voltage-divider circuits. The same steps will be followed as in the previous voltage divider problem.

Given:

$$\begin{aligned}\text{Load 1: } E &= 90\text{V} \\ I &= 10\text{mA}\end{aligned}$$

$$\begin{aligned}\text{Load 2: } E &= 150\text{V} \\ I &= 10\text{mA}\end{aligned}$$

$$\begin{aligned}\text{Load 3: } E &= 175\text{V} \\ I &= 30\text{mA}\end{aligned}$$

$$E_s = 285\text{V}$$

The bleeder current should be 10% of the total load current.

$$\begin{aligned}I_{R1} &= 10\% \times I(\text{load total}) \\ I_{R1} &= 10\% \times (10\text{mA} + 10\text{mA} + 30\text{mA}) \\ I_{R1} &= 5\text{mA}\end{aligned}$$

Since the voltage across R_1 (E_{R1}) is equal to the voltage requirement for load 1, Ohm's law can be used to calculate the value for R_1 .

$$R_1 = \frac{E_{R1}}{I_{R1}}$$

$$R_1 = \frac{90\text{V}}{5\text{mA}}$$

$$R_1 = 18\text{k}\Omega$$

The current through R_2 (I_{R2}) is equal to the current through R_1 plus the current through load 1.

$$\begin{aligned}I_{R2} &= I_{R1} + I_{\text{load1}} \\ I_{R2} &= 5\text{mA} + 10\text{mA} \\ I_{R2} &= 15\text{mA}\end{aligned}$$

The voltage across R_2 (E_{R2}) is equal to the difference between the voltage requirements of load 1 and load 2.

$$\begin{aligned}E_{R2} &= E_{\text{load2}} - E_{\text{load1}} \\E_{R2} &= 150\text{V} - 90\text{V} \\E_{R2} &= 60\text{V}\end{aligned}$$

Ohm's law can now be used to solve for the value of R_2 .

$$\begin{aligned}R_2 &= \frac{E_{R2}}{I_{R2}} \\R_2 &= \frac{60\text{V}}{15\text{mA}} \\R_2 &= 4\text{k}\Omega\end{aligned}$$

The current through R_3 (I_{R3}) is equal to the current through R_2 plus the current through load 2.

$$\begin{aligned}I_{R3} &= I_{R2} + I_{\text{load2}} \\I_{R3} &= 15\text{mA} + 10\text{mA} \\I_{R3} &= 25\text{mA}\end{aligned}$$

The voltage across R_3 (E_{R3}) equals the difference between the voltage requirement of load 3 and load 2.

$$\begin{aligned}E_{R3} &= E_{\text{load3}} - E_{\text{load2}} \\E_{R3} &= 175\text{V} - 150\text{V} \\E_{R3} &= 25\text{V}\end{aligned}$$

Ohm's law can now be used to solve for the value of R_3 .

$$\begin{aligned}R_3 &= \frac{E_{R3}}{I_{R3}} \\R_3 &= \frac{25\text{V}}{25\text{mA}} \\R_3 &= 1\text{k}\Omega\end{aligned}$$

The current through R_4 (I_{R4}) is equal to the current through R_3 plus the current through load 3. I_{R4} is equal to total circuit current (I_T).

$$\begin{aligned}I_{R4} &= I_{R3} + I_{load3} \\I_{R4} &= 25\text{mA} + 30\text{mA} \\I_{R4} &= 55\text{mA}\end{aligned}$$

The voltage across R_4 (E_{R4}) equals the difference between the source voltage and the voltage requirement of load 3.

$$\begin{aligned}E_{R4} &= E_S - E_{load3} \\E_{R4} &= 285\text{V} - 175\text{V} \\E_{R4} &= 110\text{V}\end{aligned}$$

Ohm's law can now be used to solve for the value of R_4 .

$$\begin{aligned}R_4 &= \frac{E_{R4}}{I_{R4}} \\R_4 &= \frac{110\text{V}}{55\text{mA}} \\R_4 &= 2\text{k}\Omega\end{aligned}$$

With the calculations just explained, the values of the resistors used in the voltage divider are as follows:

$$\begin{aligned}R_1 &= 18\text{k}\Omega \\R_2 &= 4\text{k}\Omega \\R_3 &= 1\text{k}\Omega \\R_4 &= 2\text{k}\Omega\end{aligned}$$

Knowledge Check

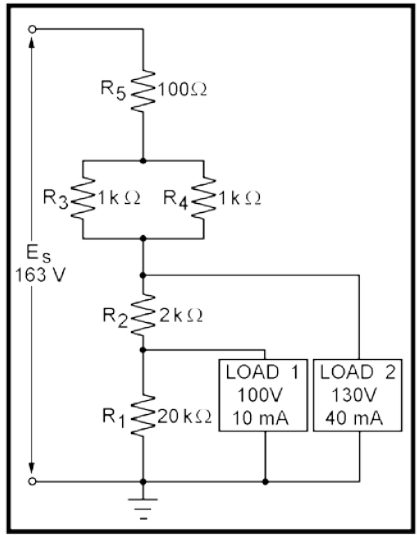

32NVE151

1. In the circuit above, why must the value of R1 be calculated first?
 - a. For convenience
 - b. The current through R2 depends on the
 - c. value of R1
 - d. The voltage drop across R1 depends on the value of load 1
 - e. In any circuit, values for resistors labeled R1 are calculated first

2. In the circuit above, how is the current through R2 calculated?
 - a. By adding IR1 and the current requirement of load 1
 - b. By adding the current requirements of load 1 and load 2
 - c. By subtracting the current requirement of load 1 from the current requirement of load 2
 - d. By subtracting the current requirement of load 2 from the current requirement of load 1

3. In the circuit above, how is the voltage drop across R2 calculated?
 - a. By adding the voltage requirements of load 1 and load 2
 - b. By subtracting the voltage drops across R5 and R3 from the source voltage
 - c. By subtracting the voltage requirement of load 1 from the voltage requirement of load 2
 - d. By subtracting the voltage requirements of load 1 and load 2 from the source voltage

4. In the circuit above, what is the minimum wattage rating required for R5?
 - a. 1 W
 - b. 2 W
 - c. 1/2 W
 - d. 1/4 W

5. In the circuit above, what is the total power supplied by the source?
 - a. 3.765 W
 - b. 7.965 W
 - c. 8.209 W
 - d. 8.965 W

6. In the circuit above, what is the purpose of using the series-parallel network consisting of R3, R4, and R5 in place of a single resistor?
 - a. It provides the desired resistance with resistor values that are easily obtainable
 - b. It provides the close tolerance required for the circuit
 - c. It is more reliable than the use of a single resistor
 - d. It costs less by using three resistors of lower wattage rating than a single, large power resistor

Power in the Voltage Divider

Power in the voltage divider is an extremely important quantity. The power dissipated by the resistors in the voltage divider should be calculated to determine the power handling requirements of the resistors. Total power of the circuit is needed to determine the power requirement of the source.

The power for the circuit shown in Figure 3 is calculated as follows:

Given: $E_{R1} = 90V$
 $I_{R1} = 5mA$

Solution: $P_{R1} = E_{R1} \times I_{R1}$
 $P_{R1} = 90V \times 5mA$
 $P_{R1} = .45W$

Air Washington Electronics – Direct Current

The power in each resistor is calculated just as for R_1 . When the calculations are performed, the following results are obtained:

$$\begin{aligned}P_{R2} &= .9\text{W} \\P_{R3} &= .625\text{W} \\P_{R4} &= 6.05\text{W}\end{aligned}$$

To calculate the power for load 1:

Given:

$$\begin{aligned}E_{\text{load1}} &= 90\text{V} \\I_{\text{load1}} &= 10\text{mA}\end{aligned}$$

Solution:

$$\begin{aligned}P_{\text{load1}} &= E_{\text{load1}} \times I_{\text{load1}} \\P_{\text{load1}} &= 90\text{V} \times 10\text{mA} \\P_{\text{load1}} &= .9\text{W}\end{aligned}$$

The power in each load is calculated just as for load 1. When the calculations are performed, the following results are obtained.

$$\begin{aligned}P_{\text{load2}} &= 1.5\text{W} \\P_{\text{load3}} &= 5.25\text{W}\end{aligned}$$

Total power is calculated by summing the power consumed by the loads and the power dissipated by the divider resistors. The total power in the circuit is 15.675 watts. The power used by the loads and divider resistors is supplied by the source. This applies to all electrical circuits; power for all components is supplied by the source. Since power is the product of voltage and current, the power supplied by the source is equal to the source voltage multiplied by the total circuit current ($E_s \times I_T$).

In the circuit of Figure 3, the total power can be calculated by:

Given:

$$\begin{aligned}E_s &= 285\text{V} \\I_T &= 55\text{mA} (I_{R4})\end{aligned}$$

Solution:

$$P_T = E_s \times I_T$$
$$P_T = 285V \times 55mA$$
$$P_T = 15.675W$$

Voltage Divider with Positive & Negative Voltage Requirements

In many cases the load for a voltage divider requires both positive and negative voltages.

Positive and negative voltages can be supplied from a single source voltage by connecting the ground (reference point) between two of the divider resistors. The exact point in the circuit at which the reference point is placed depends upon the voltages required by the loads.

For example, a voltage divider can be designed to provide the voltage and current to three loads from a given source voltage.

Given:

Load 1: $E = -25V$
 $I = 300mA$

Load 2: $E = +50V$
 $I = 50mA$

Load 3: $E = +250V$
 $I = 100mA$

$E_s = 310V$

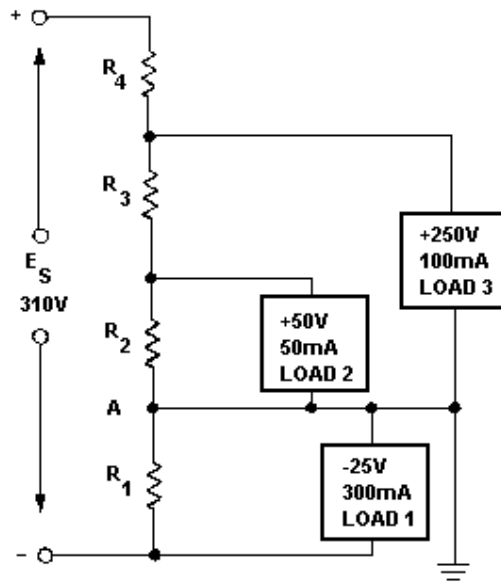

Figure 4: Voltage divider providing both positive and negative voltages

The circuit is drawn as shown in Figure 4. Notice the placement of the ground reference point. The values for resistors R_1 , R_3 , and R_4 are computed exactly as was done in the last example. I_{R1} is the bleeder current and can be calculated as follows:

Solution:

$$I_{R1} = 10\% \times I(\text{load total})$$

$$I_{R1} = 10\% \times (300\text{mA})$$

$$I_{R1} = 30\text{mA}$$

Calculate the value of R_1 .

$$R_1 = \frac{E_{R1}}{I_{R1}}$$

$$R_1 = \frac{25\text{V}}{45\text{mA}}$$

$$R_1 = 556\Omega$$

Calculate the current through R_2 using Kirchhoff's current law. At point A:

$$\begin{aligned} I_{R1} + I_{load1} + I_{R2} + I_{load2} + I_{load3} &= 0 \\ 45\text{mA} + 300\text{mA} + I_{R2} - 50\text{mA} - 100\text{mA} &= 0 \\ 345\text{mA} + I_{R2} - 150\text{mA} &= 0 \\ 195\text{mA} + I_{R2} &= 0 \\ I_{R2} &= -195\text{mA} \end{aligned}$$

Since $E_{R2} = E_{load2}$, you can calculate the value of R_2 . Solution:

$$\begin{aligned} R_2 &= \frac{E_{R2}}{I_{R2}} \\ R_2 &= \frac{50\text{V}}{195\text{mA}} \\ R_2 &= 256\Omega \end{aligned}$$

Calculate the current through R_3 .

$$\begin{aligned} I_{R3} &= I_{R2} + I_{load2} \\ I_{R3} &= 195\text{mA} + 50\text{mA} \\ I_{R3} &= 245\text{mA} \end{aligned}$$

The voltage across R_3 (E_{R3}) equals the difference between the voltage requirements of loads 3 and 2.

$$\begin{aligned} E_{R3} &= E_{load3} - E_{load2} \\ E_{R3} &= 250\text{V} - 50\text{V} \\ E_{R3} &= 200\text{V} \end{aligned}$$

Calculate the value of R_3 .

$$\begin{aligned} R_3 &= \frac{E_{R3}}{I_{R3}} \\ R_3 &= \frac{200\text{V}}{245\text{mA}} \\ R_3 &= 816\Omega \end{aligned}$$

Calculate the current through R_4 .

$$\begin{aligned} I_{R4} &= I_{R3} + I_{load3} \\ I_{R4} &= 245\text{mA} + 100\text{mA} \\ I_{R4} &= 345\text{mA} \end{aligned}$$

The voltage across E_{R4} equals the source voltage (E_s) minus the voltage requirement of load 3 and the voltage requirement of load 1. Remember Kirchhoff's voltage law which states that the sum of the voltage drops and emfs around any closed loop is equal to zero.

$$\begin{aligned}E_{R4} &= E_s - E_{load3} - E_{load1} \\E_{R4} &= 310V - 250V - 25V \\E_{R4} &= 35V\end{aligned}$$

Calculate the value of R_4 .

$$\begin{aligned}R_4 &= \frac{E_{R4}}{I_{R4}} \\R_4 &= \frac{35V}{345mA} \\R_4 &= 101.4\Omega\end{aligned}$$

With the calculations just explained, the values of the resistors used in the voltage/divider are as follows:

$$\begin{aligned}R_1 &= 556\Omega \\R_2 &= 256\Omega \\R_3 &= 816\Omega \\R_4 &= 101\Omega\end{aligned}$$

From the information just calculated, any other circuit quantity, such as power, total current, or resistance of the load, could be calculated.

Knowledge Check

1. A single voltage divider provides both negative and positive voltages from a single source voltage through the use of a:
 - a. ground between two of the dividing resistors
 - b. ground to the positive terminal of the source
 - c. ground to the negative terminal of the source
 - d. ground to the input of all loads requiring a negative voltage

Practical Application of Voltage Dividers

In actual practice the computed value of the bleeder resistor does not always come out to an even value. Since the rule-of-thumb for bleeder current is only an estimated value, the bleeder resistor can be of a value close to the computed value. (If the computed value of the resistance were 510 ohms, a 500- ohm resistor could be used.) Once the actual value of the bleeder resistor is selected, the bleeder current must be recomputed. The voltage developed by the bleeder resistor must be equal to the voltage requirement of the load in parallel with the bleeder resistor.

The value of the remaining resistors in the voltage divider is computed from the current through the remaining resistors and the voltage across them. These values must be used to provide the required voltage and current to the loads.

If the computed values for the divider resistors are not even values; series, parallel, or series-parallel networks can be used to provide the required resistance.

Example: A voltage divider is required to supply two loads from a 190.5 volts source. Load 1 requires +45 volts and 210 milliamps; load 2 requires +165 volts and 100 milliamps.

Calculate the bleeder current using the rule-of-thumb.

Given: $I_{load1} = 210mA$
 $I_{load2} = 100mA$

Solution: $I_{R1} = 10\% \times (210mA + 100mA)$
 $I_{R1} = 31mA$

Calculate the ohmic value of the bleeder resistor.

Given: $E_{R1} = 45V (E_{load1})$
 $I_{R1} = 31mA$

Solution: $R_1 = \frac{E_{R1}}{I_{R1}}$
 $R_1 = \frac{45V}{31mA}$
 $R_1 = 1451.6\Omega$

Since it would be difficult to find a resistor of 1451.6 ohms, a practical choice for R_1 is 1500 ohms. Calculate the actual bleeder current using the selected value for R_1 .

Given: $E_{R1} = 45V$
 $R_1 = 1.5k\Omega$

Solution: $I_{R1} = \frac{E_{R1}}{R_1}$
 $I_{R1} = \frac{45V}{1.5k\Omega}$
 $I_{R1} = 30mA$

Using this value for I_{R1} , calculate the resistance needed for the next divider resistor. The current (I_{R2}) is equal to the bleeder current plus the current used by load 1.

Given: $I_{R1} = 30mA$
 $I_{load1} = 210mA$

Solution: $I_{R2} = I_{R1} + I_{load1}$
 $I_{R2} = 30mA + 210mA$
 $I_{R2} = 240mA$

The voltage across R_2 (E_{R2}) is equal to the difference between the voltage requirements of loads 2 and 1, or 120 volts.

Calculate the value of R_2 .

Given: $E_{R2} = 120V$
 $I_{R2} = 240mA$

Solution: $R_2 = \frac{E_{R2}}{I_{R2}}$
 $R_2 = \frac{120V}{240mA}$
 $R_2 = 500\Omega$

The value of the final divider resistor is calculated with I_{R3} ($I_{R2} + I_{load 2}$) equal to 340 mA and E_{R3} ($E_s - E_{load 2}$) equal to 25.5V.

Given: $E_{R3} = 25.5V$
 $I_{R3} = 340mA$

Solution: $R_3 = \frac{E_{R3}}{I_{R3}}$
 $R_3 = \frac{25.5V}{340mA}$
 $R_3 = 75\Omega$

A 75-ohm resistor may not be easily obtainable, so a network of resistors equal to 75 ohms can be used in place of R_3 .

Any combination of resistor values adding up to 75 ohms could be placed in series to develop the required network. For example, if you had two 37.5-ohm resistors, you could connect them in series to get a network of 75 ohms. One 50-ohm and one 25-ohm resistor or seven 10-ohm and one 5-ohm resistor could also be used.

A parallel network could be constructed from two 150-ohm resistors or three 225-ohm resistors. Either of these parallel networks would also be a network of 75 ohms.

The network used in this example will be a series-parallel network using three 50-ohm resistors. With the information given, you should be able to draw this voltage divider network.

Once the values for the various divider resistors have been selected, you can compute the power used by each resistor using the methods previously explained. When the power used by each resistor is known, the wattage rating required of each resistor determines the physical size and type needed for the circuit. This circuit is shown in Figure 5.

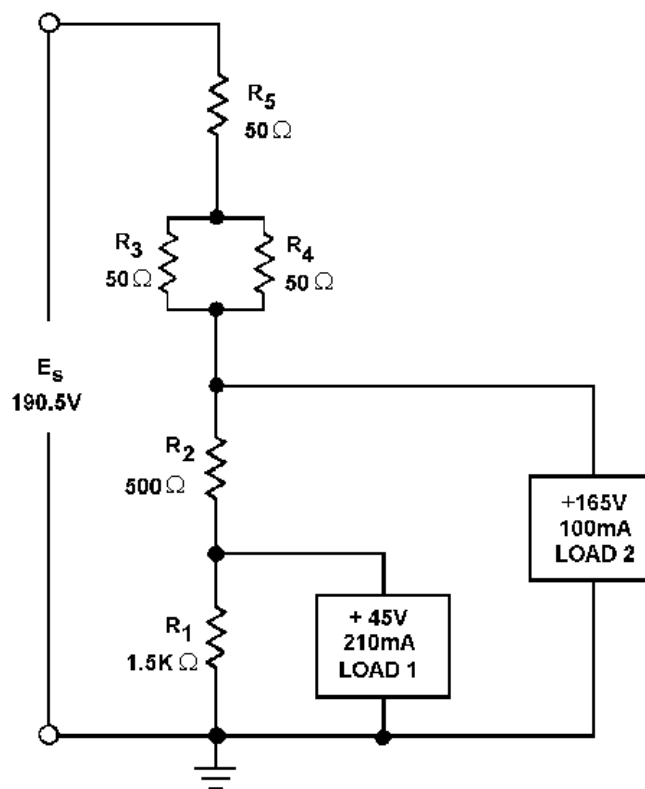

Figure 5: Practical example of a voltage divider.

Knowledge Check

1. In Figure 5, why is the value of R_1 calculated first?
2. Figure 5, how is (a) the current through R_2 and (b) the voltage drop across R_2 computed?
3. In Figure 5 what is the power dissipated in R_1 ?
4. In Figure 5, what is the purpose of the series-parallel network R_3 , R_4 , and R_5 ?
5. In Figure 5, what should be the minimum wattage ratings of R_3 and R_5 ?
6. If the load requirement consists of both positive and negative voltages, what technique is used in the voltage divider to supply the loads from a single voltage source?

Voltage Divider Circuits

Analyzing a simple series circuit, the voltage drops across individual resistors can be determined:

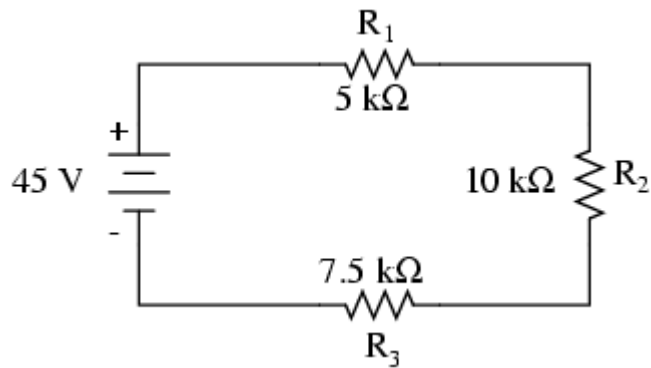

Figure 6: Analysis of a simple voltage divider.

| | R_1 | R_2 | R_3 | Total | |
|---|-------|-------|-------|-------|-------|
| E | | | | 45 | Volts |
| I | | | | | Amps |
| R | 5k | 10k | 7.5k | | Ohms |

Figure 7: Table of known values

From the given values of individual resistances, we can determine a total circuit resistance, knowing that resistances add in series:

| | R_1 | R_2 | R_3 | Total | |
|---|-------|-------|-------|--------------|-------|
| E | | | | 45 | Volts |
| I | | | | | Amps |
| R | 5k | 10k | 7.5k | 22.5k | Ohms |

Figure 8: Total circuit resistance.

From here, we can use Ohm's law to determine the total current, which will be the same as each resistor current, currents being equal in all parts of a series circuit:

| | R_1 | R_2 | R_3 | Total | |
|---|-----------|-----------|-----------|-----------|-------|
| E | | | | 45 | Volts |
| I | 2m | 2m | 2m | 2m | Amps |
| R | 5k | 10k | 7.5k | 22.5k | Ohms |

Figure 9: Ohm's law to determine current.

Now, knowing that the circuit current is 2 mA, we can use Ohm's law to calculate voltage across each resistor:

| | R_1 | R_2 | R_3 | Total | |
|---|-----------|-----------|-----------|-------|-------|
| E | 10 | 20 | 15 | 45 | Volts |
| I | 2m | 2m | 2m | 2m | Amps |
| R | 5k | 10k | 7.5k | 22.5k | Ohms |

Figure 10: Ohm's law to determine voltage drops.

It should be apparent that the voltage drop across each resistor is proportional to its resistance, given that the current is the same through all resistors. Notice how the voltage across R_2 is double that of the voltage across R_1 , just as the resistance of R_2 is double that of R_1 .

If we were to change the total voltage, we would find this proportionality of voltage drops remains constant:

| | R_1 | R_2 | R_3 | Total | |
|---|-------|-------|-------|-------|-------|
| E | 40 | 80 | 60 | 180 | Volts |
| I | 8m | 8m | 8m | 8m | Amps |
| R | 5k | 10k | 7.5k | 22.5k | Ohms |

Figure 11: Individual voltage drops are proportional to resistance.

The voltage across R_2 is still exactly twice that of R_1 's drop, despite the fact that the source voltage has changed. The proportionality of voltage drops (ratio of one to another) is strictly a function of resistance values.

With a little more observation, it becomes apparent that the voltage drop across each resistor is also a fixed proportion of the supply voltage. The voltage across R_1 , for example, was 10 volts when the battery supply was 45 volts. When the battery voltage was increased to 180 volts (4 times as much), the voltage drop across R_1 also increased by a factor of 4 (from 10 to 40 volts). The **ratio** between R_1 's voltage drop and total voltage, however, did not change:

$$\frac{E_{R1}}{E_{total}} = \frac{10 \text{ V}}{45 \text{ V}} = \frac{40 \text{ V}}{180 \text{ V}} = 0.22222$$

Figure 12: Relationship between voltage drops and total voltage.

Likewise, none of the other voltage drop ratios changed with the increased supply voltage either:

$$\frac{E_{R2}}{E_{total}} = \frac{20 \text{ V}}{45 \text{ V}} = \frac{80 \text{ V}}{180 \text{ V}} = 0.44444$$

$$\frac{E_{R3}}{E_{total}} = \frac{15 \text{ V}}{45 \text{ V}} = \frac{60 \text{ V}}{180 \text{ V}} = 0.33333$$

Figure 13: Ratios between voltage drops and total voltage

For this reason a series circuit is often called a voltage divider for its ability to proportion -- or divide -- the total voltage into fractional portions of constant ratio. With a little bit of algebra, we can derive a formula for determining series resistor voltage drop given nothing more than total voltage, individual resistance, and total resistance:

| | |
|---|---|
| Voltage drop across <i>any</i> resistor | $E_n = I_n R_n$ |
| Current in a series circuit | $I_{total} = \frac{E_{total}}{R_{total}}$ |
| ... <i>Substituting</i> $\frac{E_{total}}{R_{total}}$ <i>for</i> I_n <i>in the first equation</i> ... | |
| Voltage drop across any <i>series</i> resistor | $E_n = \frac{E_{total}}{R_{total}} R_n$ |
| ... Or ... | |
| <div style="border: 1px solid black; padding: 10px; width: fit-content; margin: 0 auto;"> $E_n = E_{total} \frac{R_n}{R_{total}}$ </div> | |

Figure 14: Voltage divider formula.

The ratio of individual resistance to total resistance is the same as the ratio of individual voltage drop to total supply voltage in a voltage divider circuit. This is known as the **voltage divider formula**, and it is a short-cut method for determining voltage drop in a series circuit without going through the current calculation(s) of Ohm's law.

Using this formula, we can re-analyze the voltage drops of Figure 6 in fewer steps:

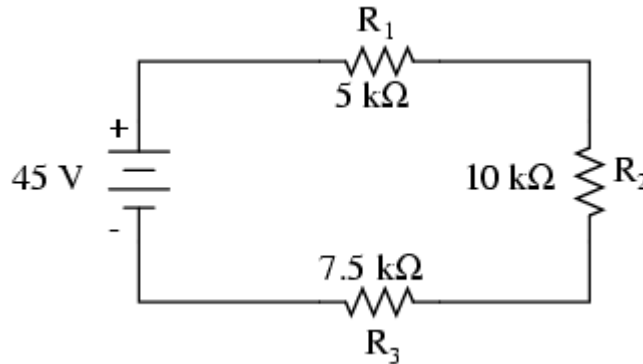

$$E_{R1} = 45 \text{ V} \frac{5 \text{ k}\Omega}{22.5 \text{ k}\Omega} = 10 \text{ V}$$

$$E_{R2} = 45 \text{ V} \frac{10 \text{ k}\Omega}{22.5 \text{ k}\Omega} = 20 \text{ V}$$

$$E_{R3} = 45 \text{ V} \frac{7.5 \text{ k}\Omega}{22.5 \text{ k}\Omega} = 15 \text{ V}$$

Figure 15: Analysis of Figure 6 using voltage divider formula

Voltage dividers find wide application in electric meter circuits, where specific combinations of series resistors are used to "divide" a voltage into precise proportions as part of a voltage measurement device.

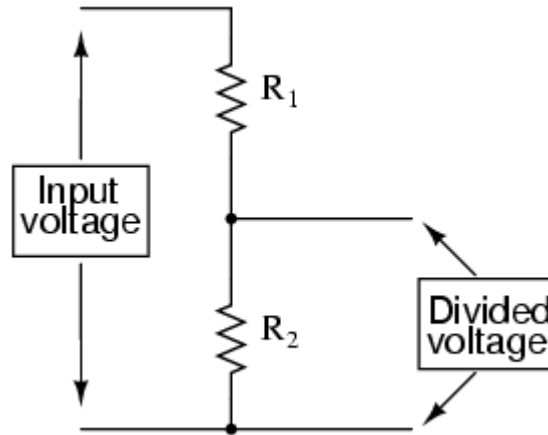

Figure 16: A voltage divider circuit.

Media Resources

Wisc-Online.com

- [Voltage Divider Rule](#)

Knowledge Check

1. [Voltage Divider Rule Practice Problems](#) from Wisc-Online.com

Potentiometer as Voltage Divider

One device frequently used as a voltage-dividing component is the **potentiometer**, which is a resistor with a movable element positioned by a manual knob or lever. The movable element, typically called a **wiper**, makes contact with a resistive strip of material (commonly called the **slide wire** if made of resistive metal wire) at any point selected by the manual control:

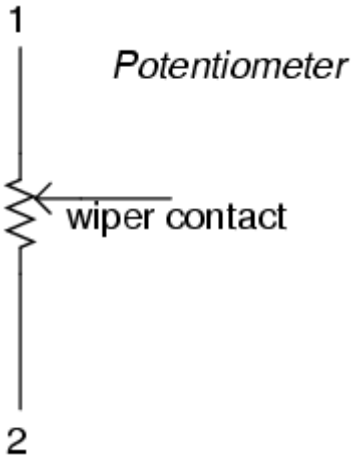

Figure 17: Potentiometer

As indicated in Figure 17, the wiper contact is the left-facing arrow symbol drawn in the middle of the vertical resistor element. As it is moved up, it contacts the resistive strip closer to terminal 1 and further away from terminal 2, lowering resistance to terminal 1 and raising resistance to terminal 2. As it is moved down, the opposite effect results (Figure 18). The resistance as measured between terminals 1 and 2 is constant for any wiper position.

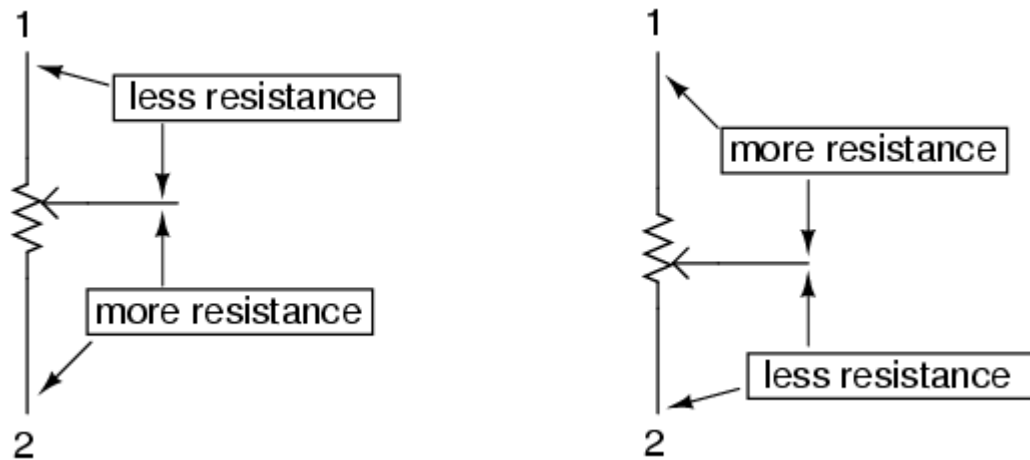

Figure 18: Schematic of Potentiometer

Shown in Figure 19 are internal illustrations of two potentiometer types, rotary and linear:

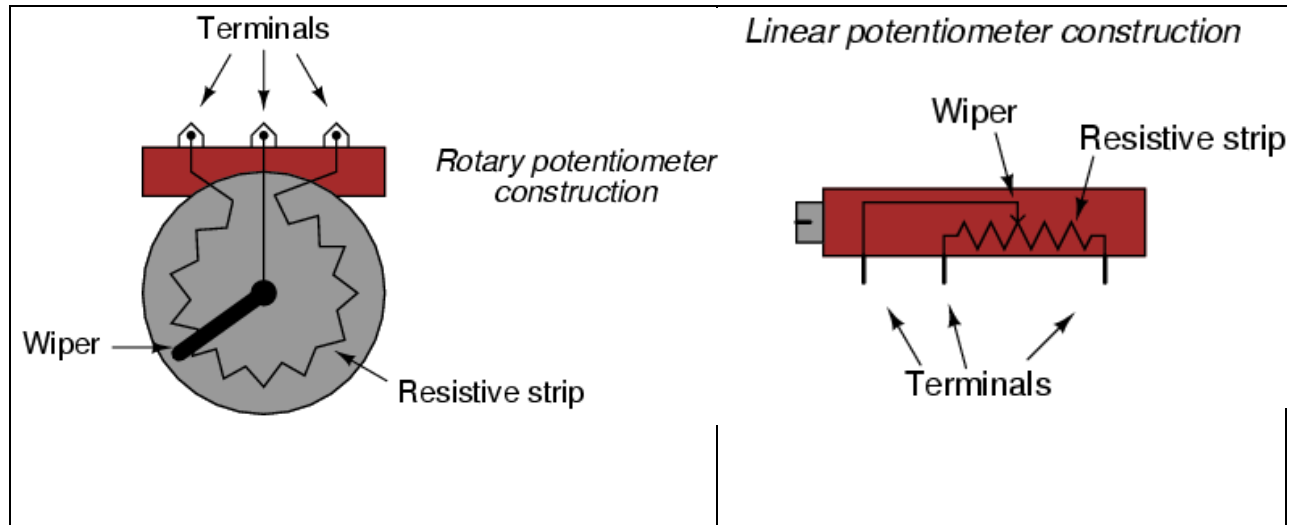

Figure 19: Internal illustrations of potentiometers.

Some linear potentiometers are actuated by straight-line motion of a lever or slide button. Others, like the one depicted in the previous illustration, are actuated by a turn-screw for fine adjustment ability. The latter units are sometimes referred to as **trim pots**, because they work well for applications requiring a variable resistance to be "trimmed" to some precise value. It should be noted that not all linear potentiometers have the same terminal assignments as shown in this illustration. With some, the wiper terminal is in the middle, between the two end terminals.

Figure 20 shows a real, rotary potentiometer with exposed wiper and slide wire for easy viewing. The shaft which moves the wiper has been turned almost fully clockwise so that the wiper is nearly touching the left terminal end of the slide wire:

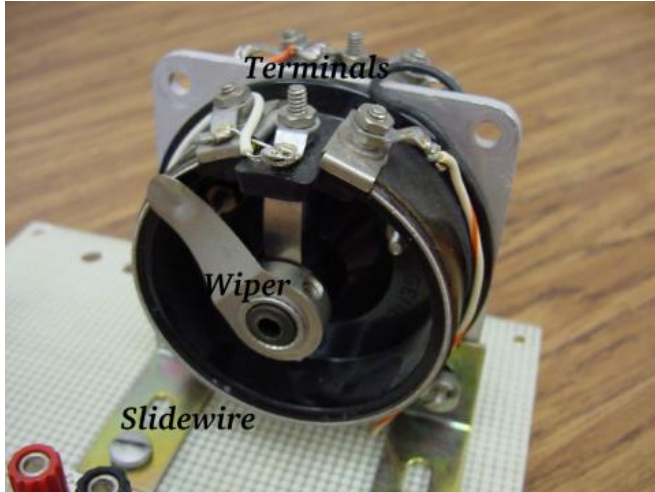

Figure 21: Rotary Potentiometer with wiper turned completely to the left.

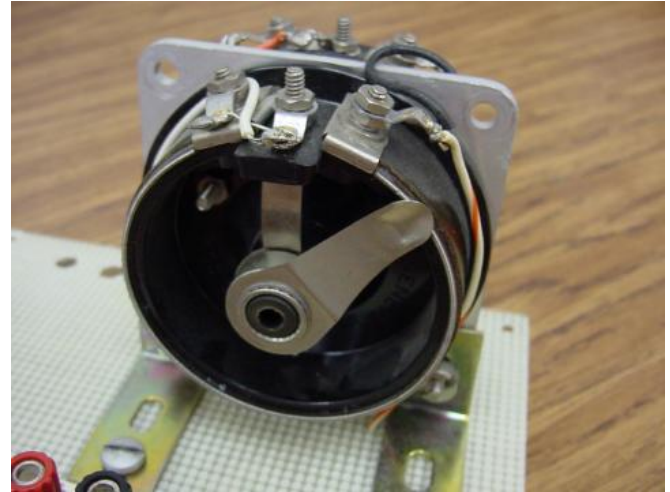

Figure 20: Rotary Potentiometer with wiper turned completely to the right.

Figure 21 shows the same potentiometer with the wiper shaft moved almost to the full-counterclockwise position, so that the wiper is near the other extreme end of travel.

If a constant voltage is applied between the outer terminals (across the length of the slide wire), the wiper position will tap off a fraction of the applied voltage, measurable between the wiper contact and either of the other two terminals. The fractional value depends entirely on the physical position of the wiper, as shown in Figure 22:

Using a potentiometer as a variable voltage divider

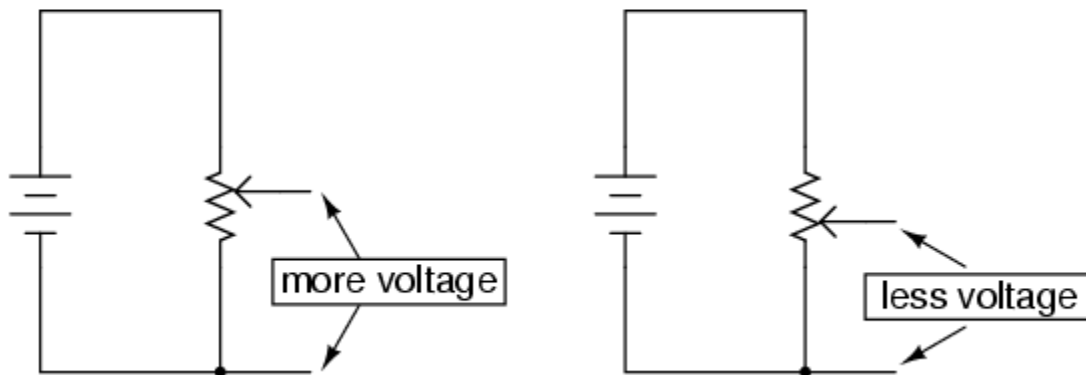

Figure 22: Potentiometer as variable voltage divider.

Just like the fixed voltage divider, the potentiometer's voltage **division ratio** is strictly a function of resistance and not of the magnitude of applied voltage. In other words, if the potentiometer knob or lever is moved to the 50 percent (exact center) position, the voltage dropped between wiper and either outside terminal would be exactly 1/2 of the applied voltage, no matter what that voltage happens to be, or what the end-to-end resistance of the potentiometer is. In other words, a potentiometer functions as a variable voltage divider where the voltage division ratio is set by wiper position.

This application of the potentiometer is a very useful means of obtaining a variable voltage from a fixed-voltage source such as a battery. If a circuit you're building requires a certain amount of voltage that is less than the value of an available battery's voltage, you may connect the outer terminals of a potentiometer across that battery and "dial up" whatever voltage you need between the potentiometer wiper and one of the outer terminals for use in your circuit:

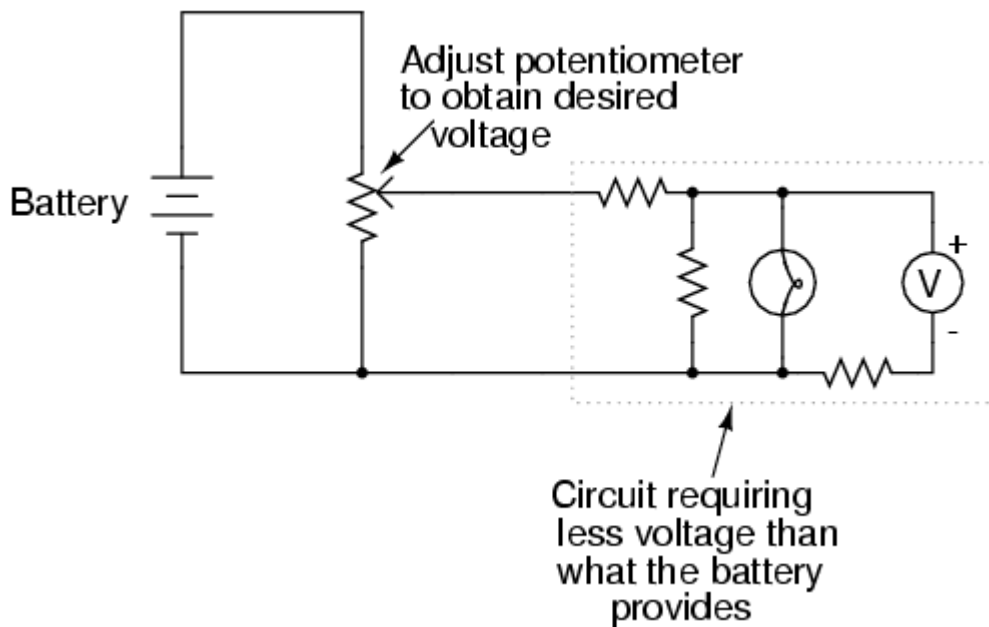

Figure 23: Practical application of a potentiometer as voltage divider.

When used in this manner, the name potentiometer makes perfect sense: they meter (control) the potential (voltage) applied across them by creating a variable voltage-divider ratio. This use

of the three-terminal potentiometer as a variable voltage divider is very popular in circuit design.

Current divider circuits

Let's analyze a simple parallel circuit, determining the branch currents through individual resistors:

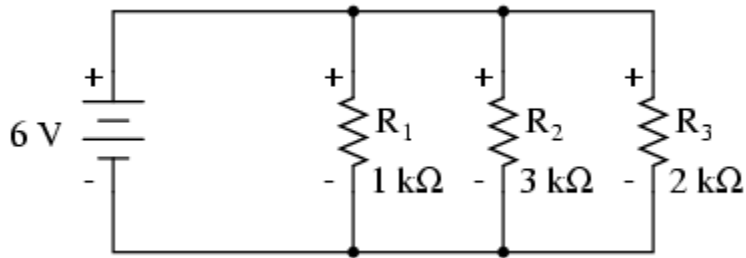

Figure 24: Analysis of a simple current divider circuit.

Knowing that voltages across all components in a parallel circuit are the same, we can fill in our voltage/current/resistance table with 6 volts across the top row:

| | R ₁ | R ₂ | R ₃ | Total | |
|---|----------------|----------------|----------------|-------|-------|
| E | 6 | 6 | 6 | 6 | Volts |
| I | | | | | Amps |
| R | 1k | 3k | 2k | | Ohms |

Figure 25: Table of known values.

Using Ohm's law we can calculate each branch current:

| | R_1 | R_2 | R_3 | Total | |
|---|-----------|-----------|-----------|-------|-------|
| E | 6 | 6 | 6 | 6 | Volts |
| I | 6m | 2m | 3m | | Amps |
| R | 1k | 3k | 2k | | Ohms |

Figure 26: Use Ohm's law to determine each branch current.

Knowing that branch currents add up in parallel circuits to equal the total current, we can arrive at total current by summing 6 mA, 2 mA, and 3 mA:

| | R_1 | R_2 | R_3 | Total | |
|---|-------|-------|-------|------------|-------|
| E | 6 | 6 | 6 | 6 | Volts |
| I | 6m | 2m | 3m | 11m | Amps |
| R | 1k | 3k | 2k | | Ohms |

Figure 27: Use rules of parallel circuits to determine total current.

The final step, of course, is to figure total resistance. This can be done with Ohm's law in the "total" column, or with the parallel resistance formula from individual resistances. Either way, we'll get the same answer:

| | R_1 | R_2 | R_3 | Total | |
|---|-------|-------|-------|---------------|-------|
| E | 6 | 6 | 6 | 6 | Volts |
| I | 6m | 2m | 3m | 11m | Amps |
| R | 1k | 3k | 2k | 545.45 | Ohms |

Figure 28: Use Ohm's law to determine total resistance.

Once again, it should be apparent that the current through each resistor is related to its resistance, given that the voltage across all resistors is the same. Rather than being directly proportional, the relationship here is one of inverse proportion. For example, the current through R_1 is twice as much as the current through R_3 , which has twice the resistance of R_1 .

If we were to change the supply voltage of this circuit, we find that these proportional ratios do not change:

| | R_1 | R_2 | R_3 | Total | |
|---|-------|-------|-------|--------|-------|
| E | 24 | 24 | 24 | 24 | Volts |
| I | 24m | 8m | 12m | 44m | Amps |
| R | 1k | 3k | 2k | 545.45 | Ohms |

Figure 29: Individual currents are proportional to resistance.

The current through R_1 is still exactly twice that of R_3 , despite the fact that the source voltage has changed. The proportionality between different branch currents is strictly a function of resistance.

Also reminiscent of voltage dividers is the fact that branch currents are fixed proportions of the total current. Despite the fourfold increase in supply voltage, the ratio between any branch current and the total current remains unchanged:

$$\frac{I_{R1}}{I_{total}} = \frac{6 \text{ mA}}{11 \text{ mA}} = \frac{24 \text{ mA}}{44 \text{ mA}} = 0.54545$$

$$\frac{I_{R2}}{I_{total}} = \frac{2 \text{ mA}}{11 \text{ mA}} = \frac{8 \text{ mA}}{44 \text{ mA}} = 0.18182$$

$$\frac{I_{R3}}{I_{total}} = \frac{3 \text{ mA}}{11 \text{ mA}} = \frac{12 \text{ mA}}{44 \text{ mA}} = 0.27273$$

Figure 30: Ratios between branch currents and total current.

For this reason a parallel circuit is often called a current divider for its ability to proportion -- or divide -- the total current into fractional parts. With a little bit of algebra, we can derive a formula for determining parallel resistor current given nothing more than total current, individual resistance, and total resistance:

| | |
|---|--|
| Current through <i>any</i> resistor | $I_n = \frac{E_n}{R_n}$ |
| Voltage in a parallel circuit | $E_{\text{total}} = E_n = I_{\text{total}} R_{\text{total}}$ |
| <i>... Substituting $I_{\text{total}} R_{\text{total}}$ for E_n in the first equation ...</i> | |
| Current through any <i>parallel</i> resistor | $I_n = \frac{I_{\text{total}} R_{\text{total}}}{R_n}$ |
| ... Or ... | |
| <div style="border: 1px solid black; padding: 10px; width: fit-content; margin: 0 auto;"> $I_n = I_{\text{total}} \frac{R_{\text{total}}}{R_n}$ </div> | |

Figure 31: Current divider formula.

The ratio of total resistance to individual resistance is the same ratio as individual (branch) current to total current. This is known as the **current divider formula**, and it is a short-cut method for determining branch currents in a parallel circuit when the total current is known.

Using the original parallel circuit as an example (Figure 24), we can re-calculate the branch currents using this formula, if we start by knowing the total current and total resistance:

$$I_{R1} = 11 \text{ mA} \frac{545.45 \Omega}{1 \text{ k}\Omega} = 6 \text{ mA}$$

$$I_{R2} = 11 \text{ mA} \frac{545.45 \Omega}{3 \text{ k}\Omega} = 2 \text{ mA}$$

$$I_{R3} = 11 \text{ mA} \frac{545.45 \Omega}{2 \text{ k}\Omega} = 3 \text{ mA}$$

Figure 32: Analysis of Figure 24 using current divider formula.

If you take the time to compare the two divider formulae, you'll see that they are remarkably similar. Notice, however, that the ratio in the voltage divider formula is R_n (individual resistance) divided by R_{Total} , and how the ratio in the current divider formula is R_{Total} divided by R_n :

| | |
|---|---|
| <i>Voltage divider formula</i> | <i>Current divider formula</i> |
| $E_n = E_{total} \frac{R_n}{R_{total}}$ | $I_n = I_{total} \frac{R_{total}}{R_n}$ |

Figure 33: Voltage divider and current divider formulas.

It is quite easy to confuse these two equations, getting the resistance ratios backwards. One way to help remember the proper form is to keep in mind that both ratios in the voltage and current divider equations must equal less than one. After all these are *divider* equations, not *multiplier* equations! If the fraction is upside-down, it will provide a ratio greater than one, which is incorrect. Knowing that total resistance in a series (voltage divider) circuit is always greater than any of the individual resistances, we know that the fraction for that formula must be R_n over R_{Total} . Conversely, knowing that total resistance in a parallel (current divider) circuit is always less than any of the individual resistances, we know that the fraction for that formula must be R_{Total} over R_n .

Current divider circuits also find application in electric meter circuits, where a fraction of a measured current is desired to be routed through a sensitive detection device. Using the current divider formula, the proper shunt resistor can be sized to proportion just the right amount of current for the device in any given instance:

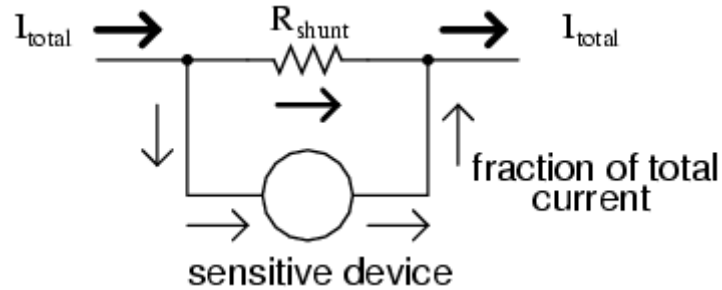

Figure 34: Application of a current divider in a meter.

Media Resources

Wisc-Online.com

- [Current Divider Rule](#)

1: Voltage Divider Circuit

Components & Equipment Needed

- DC Power Supply
- Breadboard & Jumper Wires
- Resistors: 1k (3), 270 Ω , 430 Ω , 510 Ω

Circuit Diagram

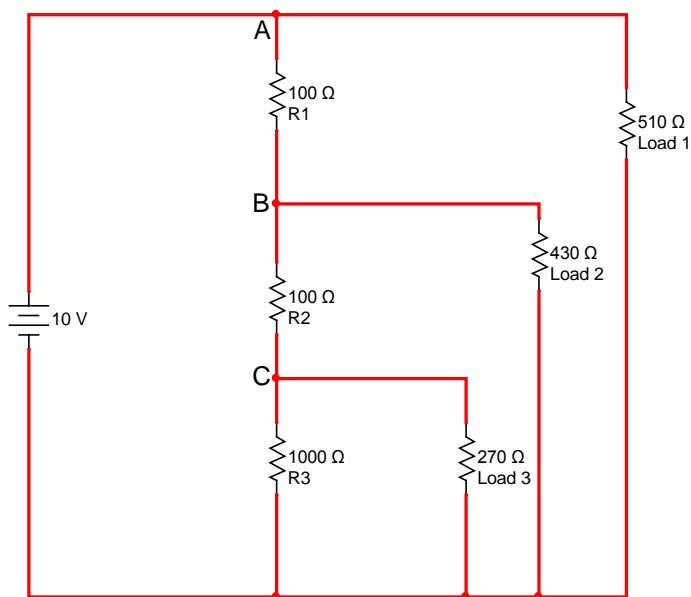

Procedure

Step 1: Build the circuit shown in the schematic.

Step 2: Take measurements and perform calculations as required in the table below.

Table for Voltage Divider Circuit Lab

| | Calculated Value | Measured Value | % Difference |
|-------------|------------------|----------------|--------------|
| V_{R1} | | | |
| V_{R2} | | | |
| V_{R3} | | | |
| V_{Load1} | | | |
| V_{Load2} | | | |
| V_{Load3} | | | |
| V_{Total} | | | |
| I_{Load1} | | | |
| I_{Load2} | | | |
| I_{Load3} | | | |
| I_{Total} | | | |
| I_b | | | |

Table 1: Voltage Divider Circuits Lab

Observations & Conclusions

In your lab report, include your results from Table 1 as well as any observations or conclusions you may have made during this exercise.

Answer following questions in your lab report:

1. If you were to remove Load 3, what would happen to total current? Does anything change in regards to Load 1 or Load 2? Please explain.

2: Designing a Loaded Voltage Divider

Components & Equipment Needed

- DC Power Supply
- Breadboard & Jumper Wires
- Resistors: TBD

Procedure

Step 1: Design a loaded voltage divider using the specifications below. Enter your calculated values in the Table 2.

- Load A requires 9 V and about 10 mA
- Load B requires 5 V and about 8 mA
- Load C requires 2 V and about 3 mA

Step 2: Build the loaded voltage divider on a breadboard using standard value ($\pm 5\%$) resistors. Be aware that your values may not come out exact, so use the best possible resistance for the circuit. Use a design similar to that shown in the schematic of the first activity (Voltage Divider Circuit).

Step 3: Measure and record the values in the table below. Calculate the percentage of difference between your calculated and measured values.

Table for Designing a Loaded Voltage Divider Circuit Lab

| | Calculated Value | Measured Value | % Difference |
|-------------|------------------|----------------|--------------|
| R_1 | | | |
| R_2 | | | |
| R_3 | | | |
| V_{R1} | | | |
| V_{R2} | | | |
| V_{R3} | | | |
| V_{Load1} | | | |
| V_{Load2} | | | |
| V_{Load3} | | | |
| V_{Total} | | | |
| I_{Load1} | | | |
| I_{Load2} | | | |
| I_{Load3} | | | |
| I_{Total} | | | |
| I_b | | | |

Table 2: Loaded Voltage Divider Circuit Lab

Observations & Conclusions

In your lab report, include your results from Table 2 as well as any observations or conclusions you may have made during this exercise.

Answer following questions in your lab report:

1. If R_3 were to open, what would happen to the rest of the circuit? Would any of the other loads be affected? Please explain your answer.

3: Critical Thinking

Your supervisor has decided that you are ready to accept new challenges and asks you to take the lead in solving a new customer's dilemma.

A new customer has decided that they would like to utilize two (2) of your company's "SuperBright 1600" lamps and the new sensor array that was recently developed. They are not interested in purchasing any of the power supplies as they already have a 100 V power supply in place that is being used to run another part of their system.

The specs for the "SuperBright 1600" indicate that they require a 24V power supply and have a resistance of $15\ \Omega$ each. The Sensor Array requires 12V and has a resistance of $1500\ \Omega$. **Recall that there is an existing requirement on the power supply of 100 V and 500 mA.**

They would like you to design a system that will allow them to operate all four (4) of these components from a single 100 V power supply.

In addition to your calculations and a table of calculated and actual values, your supervisor will want a schematic created in Multisim that he can show to the customer.

Points to remember:

- List the known values
- List the requirements
- Only $\pm 5\%$ Standard Value resistors can be used. Also, make sure they are the correct wattage. Use rated resistors in Multisim as these will "blow" if they are over loaded. For the loads, use a resistor for the simulation.

Answers to Knowledge Checks

Voltage Dividers

1. What information must be known to determine the component values for a voltage divider?

A. The source voltage and load requirements (voltage and current).

2. If a voltage divider is required for a load that will use 450 mA of current, what should be the value of bleeder current?

A. 45 mA rule-of-thumb.

3. If the load in question 50 requires a voltage of +90 V, what should be the value of the bleeder resistor?

A. 2 k Ω

4. If the source voltage for the voltage divider in question 50 supplies 150 volts, what is the total current through the voltage divider?

A. 495 mA

5. A voltage divider is required to supply a single load with +150 V and 300 mA. The source voltage is 250 V. Based on this information, answer the following questions. (Hint: Draw the circuit).

A. What should be the value of the bleeder current?

- a) 3 A
- b) 300 mA
- c) 30 mA
- d) 3 mA

B. What should be the ohmic value of the bleeder resistor?

- a) 50
- b) 500
- c) 5 k
- 50 k

C. What is the value of total current?

- a) 303 mA
- b) 330 mA
- c) 600 mA
- d) 3300 mA

Multiple-Load Voltage Dividers

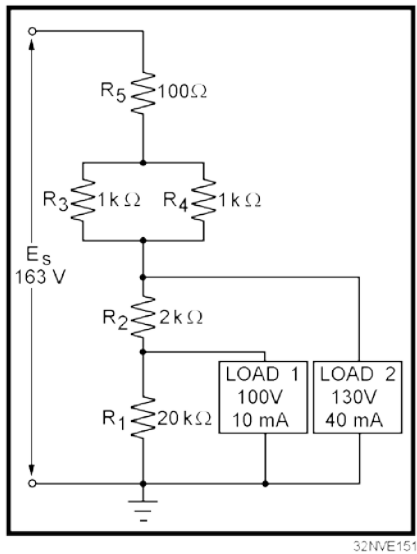

1. In the circuit above, why must the value of R1 be calculated first?
 - a. For convenience
 - b. The current through R2 depends on the
 - c. value of R1
 - d. The voltage drop across R1 depends on the value of load 1
 - e. In any circuit, values for resistors labeled R1 are calculated first

2. In the circuit above, how is the current through R2 calculated?
 - a. By adding IR1 and the current requirement of load 1
 - b. By adding the current requirements of load 1 and load 2
 - c. By subtracting the current requirement of load 1 from the current requirement of load 2
 - d. By subtracting the current requirement of load 2 from the current requirement of load 1

3. In the circuit above, how is the voltage drop across R2 calculated?
 - a. By adding the voltage requirements of load 1 and load 2
 - b. By subtracting the voltage drops across R5 and R 3 from the source voltage
 - c. By subtracting the voltage requirement of load 1 from the voltage requirement of load 2
 - d. By subtracting the voltage requirements of load 1 and load 2 from the source voltage

4. In the circuit above, what is the minimum wattage rating required for R5?
 - a. 1 W
 - b. 2 W
 - c. 1/2 W
 - d. 1/4 W

5. In the circuit above, what is the total power supplied by the source?
 - a. 3.765 W
 - b. 7.965 W
 - c. 8.209 W
 - d. 8.965 W

6. In the circuit above, what is the purpose of using the series-parallel network consisting of R3, R4, and R5 in place of a single resistor?
 - a. It provides the desired resistance with resistor values that are easily obtainable
 - b. It provides the close tolerance required for the circuit
 - c. It is more reliable than the use of a single resistor
 - d. It costs less by using three resistors of lower wattage rating than a single, large power resistor

Voltage Divider with Positive & Negative Voltage Requirements

1. A single voltage divider provides both negative and positive voltages from a single source voltage through the use of a:
 - a. ground between two of the dividing resistors
 - b. ground to the positive terminal of the source
 - c. ground to the negative terminal of the source
 - d. ground to the input of all loads requiring a negative voltage

Practical Application of Voltage Dividers

1. In Figure 5, why is the value of R_1 calculated first?
 - A. **R_1 is the bleeder resistor. Bleeder current must be known before any of the remaining divider resistor ohmic values can be computed.**
2. Figure 5, how is (a) the current through R_2 and (b) the voltage drop across R_2 computed?
 - A. **(a) By adding the bleeder current (I_{R1}) and the current through load 1 (b) By subtracting the voltage of load 1 from the voltage of load 2.**
3. In Figure 5 what is the power dissipated in R_1 ?
 - A. **1.35 W**
4. In Figure 5, what is the purpose of the series-parallel network R_3 , R_4 , and R_5 ?
 - A. **The series-parallel network drops the remaining source voltage and is used to take the place of a single resistor (75 ohms) when the required ohmic value is not available in a single resistor.**
5. In Figure 5, what should be the minimum wattage ratings of R_3 and R_5 ?
 - A. **$R_3 = 2W$; $R_5 = 6W$**
6. If the load requirement consists of both positive and negative voltages, what technique is used in the voltage divider to supply the loads from a single voltage source?
 - A. **The ground (reference point) is placed in the proper point in the voltage divider so that positive and negative voltages are supplied.**

Additional Resources

Physics Resources

Georgia State University – HyperPhysics

<http://hyperphysics.phy-astr.gsu.edu/hbase/hframe.html>

Video Resources

Khan Academy – Electricity and magnetism

<https://www.khanacademy.org/science/physics/electricity-and-magnetism>

References

Kuphaldt, T. (n.d.). *Current divider circuits*. Retrieved April 14, 2014, from All About Circuits.

Kuphaldt, T. (n.d.). *Voltage divider circuits*. Retrieved April 14, 2014, from All About Circuits:
http://www.allaboutcircuits.com/vol_1/chpt_6/1.html

United States Navy. (2003). Module 1 - Introduction to Matter, Energy, and Direct Current. In *Navy Electricity and Electronics Training Series (NEETS)*. Pensacola, FL: Naval Education and Training Professional Development and Technology Center.

Attributions

Kuphaldt, T. All about Circuits. CC BY 1.0 <http://creativecommons.org/licenses/by/1.0/>

United States Navy. Navy Electricity and Electronics Training Series (NEETS). Public Domain per
Distribution Statement A
<http://www.dtic.mil/dtic/submit/guidance/distribstatement.html>

Table of Figures

Source of figures indicated in parentheses. Some figures were modified by Olympic College.

| | |
|---|----|
| Figure 1: Voltage polarities. (US NAVY) | 4 |
| Figure 2: Simple voltage divider. (US NAVY) | 6 |
| Figure 3: Multiple-load voltage divider. (US NAVY) | 9 |
| Figure 4: Voltage divider providing both positive and negative voltages(US NAVY) | 17 |
| Figure 5: Practical example of a voltage divider. (US NAVY) | 23 |
| Figure 6: Analysis of a simple voltage divider. (Kuphaldt, T.) | 24 |
| Figure 7: Table of known values (Kuphaldt, T.) | 24 |
| Figure 8: Total circuit resistance. (Kuphaldt, T.) | 25 |
| Figure 9: Ohm’s law to determine current. (Kuphaldt, T.) | 25 |
| Figure 10: Ohm’s law to determine voltage drops. (Kuphaldt, T.) | 25 |
| Figure 11: Individual voltage drops are proportional to resistance. (Kuphaldt, T.) | 26 |
| Figure 12: Relationship between voltage drops and total voltage. (Kuphaldt, T.) | 26 |
| Figure 13: Ratios between voltage drops and total voltage (Kuphaldt, T.) | 27 |
| Figure 14: Voltage divider formula. (Kuphaldt, T.) | 27 |
| Figure 15: Analysis of Figure 6 using voltage divider formula (Kuphaldt, T.) | 28 |
| Figure 16: A voltage divider circuit. (Kuphaldt, T.) | 29 |
| Figure 17: Potentiometer (Kuphaldt, T.) | 30 |
| Figure 18: Schematic of Potentiometer (Kuphaldt, T.) | 30 |
| Figure 19: Internal illustrations of potentiometers. (Kuphaldt, T.) | 31 |
| Figure 20: Rotary Potentiometer with wiper turned completely to the left. (Kuphaldt, T.) | 32 |
| Figure 21: Rotary Potentiometer with wiper turned completely to the right. (Kuphaldt, T.) | 32 |
| Figure 22: Potentiometer as variable voltage divider. (Kuphaldt, T.) | 32 |
| Figure 23: Practical application of a potentiometer as voltage divider. (Kuphaldt, T.) | 33 |
| Figure 24: Analysis of a simple current divider circuit. (Kuphaldt, T.) | 34 |
| Figure 25: Table of known values. (Kuphaldt, T.) | 34 |
| Figure 26: Use Ohm’s law to determine each branch current. (Kuphaldt, T.) | 35 |
| Figure 27: Use rules of parallel circuits to determine total current. (Kuphaldt, T.) | 35 |
| Figure 28: Use Ohm’s law to determine total resistance. (Kuphaldt, T.) | 35 |

| | |
|--|----|
| Figure 29: Individual currents are proportional to resistance. (Kuphaldt, T.) | 36 |
| Figure 30: Ratios between branch currents and total current. (Kuphaldt, T.) | 36 |
| Figure 31: Current divider formula. (Kuphaldt, T.) | 37 |
| Figure 32: Analysis of Figure 24 using current divider formula. (Kuphaldt, T.) | 38 |
| Figure 33: Voltage divider and current divider formulas. (Kuphaldt, T.) | 38 |
| Figure 34: Application of a current divider in a meter. (Kuphaldt, T.) | 39 |

Table of Tables

Created by Olympic College

| | |
|---|----|
| Table 1: Voltage Divider Circuits Lab | 41 |
| Table 2: Loaded Voltage Divider Circuit Lab | 43 |