

## COURSE OUTLINE

<b>Course Number</b>	AM-123
<b>Title:</b>	Hybrid training
<b>Approval Date:</b>	Not yet approved
<b>Credits:</b>	3
<b>Length of course:</b>	88 lecture/lab hours
<b>Grading Method:</b>	A-F or Pass/No Pass
<b>Prerequisites:</b>	None
<b>Co- requisites</b>	None
<b>Recommended:</b>	AM-129 Electrical
<b>Required:</b>	None
<b>Certified General Education Area(s):</b>	None
<b>Related Instruction Area:</b>	None
<b>Uses library resources:</b>	None
<b>Department:</b>	Automotive Technology: Auto Mechanics
<b>Outline developed by:</b>	Rick Lockwood
<b>Course Approved as:</b>	Career Technical Preparatory

### Course Description:

Provide students with knowledge of theory and physical description of hybrid vehicles. The student will have the opportunity to acquire practical experience in the area of diagnosing and repairing hybrid vehicles.

### Student Learning Outcomes:

Upon successful completion of this course, students will be able to:

1. demonstrate how to service all hybrid systems,
2. explain how AC-DC and DC-DC converters work,
3. demonstrate how to test high voltage battery and related components,
4. demonstrate how to remove and replace high voltage battery packs.

### Major Topic Outline:

1. The history of hybrids.
  - a. How it began
  - b. series and parallel designs
2. High voltage safety
  - a. Gloves
  - b. Equipment
  - c. Warning lables

3. basic electric principles.
  - a. Ohm's law
  - b. Amp's, Ohm's, voltage, and watts
4. 3 phase motor operation.
  - a. Capacitors
  - b. Transistors
5. AC-DC Inverters
  - a. Operation of an inverter
  - b. How to test inverters
6. DC-DC converters
  - a. Operation of a converter
  - b. How to test converter
7. CVT transmission
  - a. Servicing
  - b. Theory of operation
8. Resolvers
  - a. Theory of operation
  - b. Testing
9. Interlock circuits
  - a. Theory of operation
  - b. Testing
10. Electric steering
  - a. Types of steering racks
  - b. Theory of operation
  - c. Calibrating steering racks
11. Braking system
  - a. Precautions
  - b. Testing anti-lock brake systems
  - c. Servicing hybrid brake systems
12. A/C system
  - a. Electric compressor
  - b. Servicing hybrid A/C systems
13. High voltage battery
  - a. Battery types
  - b. Servicing and testing hybrid battery's
  - c. High voltage battery removal

**COURSE DATA:**

Course Title: General repair 3 Hybrid training

Course No. AM 123

Quarter/Year: Fall/2013 Winter/2014 Spring/2014

Credits: 3

Class Meeting Times: Friday 7:30am to 2:50pm

**INSTRUCTOR INFORMATION:**

**AM 123 Instructor Name:** Rick Lockwood

**Office Location:** B-264

**Office Hours:** Fall - W,Th – 10 am – 3 pm

**Email address:** rickl@clackmas.edu

**Office Phone:** 503-594-3053

**Fax:** 503-650-6640

**Dept. Phone:** 503-594-3047

**Course Description:**

Hybrid vehicle introduction provides students with knowledge of theory and physical description of hybrid systems. The students will have the opportunity to acquire practical experience and learn the procedures for servicing and repairing hybrid vehicles.

**Course Objectives:**

This course is intended to:

- Provide the students with information on the safety hazards of hybrid vehicles.
- Explain and demonstrate service requirements that are unique to hybrid vehicles.
- Allow the students to have a real life experience of working on hybrid vehicles.

**Course Prerequisites:**

None

**Student Learning Outcomes:**

Upon successful completion of this course, students will be able to:

1. demonstrate how to service all hybrid systems,
2. explain how AC-DC and DC-DC converters work,
3. demonstrate how to test a high voltage battery and its related components,
4. demonstrate how to remove and replace high voltage battery packs.

**References:**

Manufacturer's Repair Manuals and various other tests, CD's, DVD's, work sheets and information hand-out sheets will be made available.

**Length of Course:**

11 weeks

**Required Text:**

Hybrid and Alternative Fuel Vehicles 3rd edition: by James Halderman

**Course Outline:**

1. The history of hybrids.
  - a. How it began
  - b. series and parallel designs
2. High voltage safety
  - a. Gloves
  - b. Equipment
  - c. Warning labels
3. basic electric principles.
  - a. Ohm's law
  - b. Amp's, Ohm's, voltage, and watts
4. 3 phase motor operation.
  - a. Capacitors
  - b. Transistors
5. AC-DC Inverters
  - a. Operation of an inverter
  - b. How to test inverters
6. DC-DC converters
  - a. Operation of a converter
  - b. How to test converter
7. CVT transmission
  - a. Servicing
  - b. Theory of operation
8. Resolvers
  - a. Theory of operation
  - b. Testing
9. Interlock circuits
  - a. Theory of operation
  - b. Testing
10. Electric steering

- a. Types of steering racks
- b. Theory of operation
- c. Calibrating steering racks
- 11. Braking system
  - a. Precautions
  - b. Testing anti-lock brake systems
  - c. Servicing hybrid brake systems
- 12. A/C system
  - a. Electric compressor
  - b. Servicing hybrid A/C systems
- 13. High voltage battery
  - a. Battery types
  - b. Servicing and testing hybrid battery's
  - c. High voltage battery removal

### **Reference Materials**

**Service manuals and other reference books are available for student use. They are kept in the Tech Data Center and must stay there.**

### **Withdrawal From Course**

**If you must leave the course don't just stop coming to school. Contact a counselor so that you may properly withdraw.**

### **Credit by Petition and Challenge Exams**

**If you feel that you already have the skills taught by this course you may be excluded from taking it by a credit petition procedure. To get academic credit you must take a challenge exam. See a Counselor for details.**

### **Referral To Counselor**

**If the instructor feels that the student had a problem which will hinder his/her success in the course, a counselor may be asked to contact the student so that a solution may be worked out for the problem.**

### **Safety and Accidents**

**All injuries, large or small, must be reported to the instructor. First aid kit location and procedures will be covered by the instructor. The College does not provide accident insurance. However, student health insurance is available through student services and is well worth its low cost.**

**Smoking, Food and Beverages**

**NO FOOD OR DRINKS ARE ALLOWED IN THE CLASSROOM OR SHOP AREA.  
Smoking is not allowed inside campus buildings.**

### **Diagnostic Testing**

**If you are not really sure of what you want in the way of occupational training, diagnostic testing is available from the counseling department.**

### **Learning Resource Center/Remedial Services**

**Even a mechanic has to be able to read, write and figure math with a certain degree of skill. Reading may be a skill of particular importance to a mechanic since most automotive shop manuals are written for about a 16th grade reading level. If you think you could use some help in any of these areas, don't be afraid or ashamed to ask for it. Tutorial service are available through the Learning Resource Center.**

**If you qualify for RD 12, you must earn at least one credit per term, or you would not be allowed to register for automotive classes the following term.**

### **Cleanup**

**Auto mechanics is, by nature, a somewhat dirty business. A little cleanup effort on everyone's part is necessary. Each person will be involved in a cleanup assignment.**

**Since the college does not provide cleanup service for the auto shop, it is necessary for students and instructors to cooperate in keeping the shop clean. Anyone who refuses to participate in housekeeping activities will be dismissed from the program.**

### **Shop Work**

**All shop work will be scheduled by the automotive instructors to a waiting list. The instructor will select from that list the jobs which best meet the instructional needs. There will be no unscheduled work in the shop.**

**Student mechanics assigned to a job are expected to work on and complete the assigned job in a professional manner.**

**All jobs must be paid for before the job can leave the shop.  
All vehicles must be road tested by the instructor before the vehicle is released to the owner.**

### **Lockers**

**Lockers will be furnished for your tools, books and clothing. Use them; items left laying around may be lost or stolen.**

	<b>NUMBER</b>
<b>COMBINATION</b>	
Wall Locker _____	
Tool locker → _____	

### **Clothing And Footwear**

**Clothing Requirements: Regular work shoes, safety glasses and coveralls.**

**All Students must have coveralls and safety glasses for use during lab periods. Used coveralls are available at many dry cleaning establishments for a low cost.**

**Definition of work shoes: All students must wear leather work shoes or boots. These shoes or boots must be of a stiff leather type. No student will be allowed to work in tennis shoes, soft leather running shoes or soft leather casual shoes. For the safety of all students in the shop area this rule will be strictly enforced.**

### **Attendance**

**Attendance is of number one importance in this class. Failure to attend regularly will have a definite effect on the development of your skills, your satisfactory progress in the course and your final grade. Attendance records are kept with a regular time clock and you must punch in and out each day. Your percentage of attendance is figured from your time card and is used in determining the final grade.**

**Do yourself a favor; don't waste your tuition money come to class every day.**

### **Student Expectations**

**The following is a condensation of what is expected of each student who wishes to receive a passing grade.**

- 1. Good attendance - 0% of the final grade**
- 2. Weekly work assignments - 40% of the final grade**
- 3. Final / Midterm- 30% of the final grade**

#### **4. Weekly Quizzes- 30%**

##### **Automotive Students Tested Into RD 12 (Developmental Reading)**

**RD 12 is a required course for graduation unless you can test out of it. It is specifically designed to improve your reading skills so that you can do better in your automotive classes. The course uses automotive material, and in some cases uses your automotive text books.**

**RD 12 can be of great help in doing well in your automotive courses. The automotive department policy is:**

**ALL STUDENTS WHO QUALIFY FOR RD-12 MUST EARN AT LEAST ONE CREDIT PER TERM TO BE ELIGIBLE FOR ENROLLMENT THE FOLLOWING TERM.**

##### **Grading System**

**The student's performance in the class will be evaluated on the following criteria:**

- 1. Quiz Scores 30%**
- 2. Attendance**
- 3. Project Completion 40%**
- 4. Final/Midterm 30%**

##### **Test Scores:**

**There will be 9 quizzes one final and one midterm exam.**

##### **Grade Scale:**

**90-100 A**  
**80-89 B**  
**70-79 C**  
**60-69 D**  
**Less than 60 F**

##### **Incomplete:**

**An incomplete grade will be given to the student if the instructor feels that he/she falls within the following areas:**



- 1. The student has not enough time in class for the instructor to determine a valid letter grade.**
- 2. The student had an accident or illness which prevented successful completion of the term.**
- 3. Not all of the tests and projects have been completed.**

### **REPAIR ORDER POLICY**

**It is the policy of the Automotive Department to give a student an INCOMPLETE if the student has NOT closed out his/her repair order by the end of each term. All parts must be paid for at the time of purchase.**

### **Withdraw:**

**The "W" grade will be given to a student who spends less than 50% of the term in class and has completed little or none of the required work. A withdrawal grade may be given if the individual ceases coming to class but does not officially drop the class through the registrar's office.**

### **Tools:**

**Each student must have a basic mechanic's tool set. The cost of this set is \$800 to \$3000. The list of tools on the last page of this syllabus is the required tool list for automotive courses. Automotive students must have the tools on the required tool list within two weeks of the beginning of the term. Students who do not have all tools on the list will not be able to participate in shop activities which require tools.**

### **SAFETY RULES**

#### **Handling Liquids Safely**

- 1. Know the location and use for various fire extinguishers for each type of fire.**
- 2. Using open flames or striking spark is prohibited in rooms where flammable liquids are used or stored.**
- 3. Sparks near an automobile storage battery creates a hazard and can cause an accident. The accumulation of hydrogen in the top of the cell during a charge is very explosive. Do not test a battery by flashing the terminals with a piece of wire.**

**4. When removing the battery from the car always use a battery strap or carrier. Hold the battery upright so there is no danger of spilling acid, and hold it away from your body. Always wear protective clothing when working around batteries.**

**5. Handle brake fluid carefully so that it does not splash in the eyes or on the skin.**

**6. It should not be necessary to siphon gasoline from the tank. However, if this is done, do not start siphoning by mouth. Gasoline often contains poisonous tetraethyl lead.**

**7. Keep only small quantities of gasoline, stored in safety containers properly labeled, in the shop. Store all flammable liquids in a fireproof room that has been approved by the Fire Marshall.**

**8. Do not operate an engine if there is a gasoline leak from the carburetor, fuel pump or gas lines.**

**9. Avoid placing live wires near fuel lines, carburetor or gas tank. Before starting the engine, make certain that it is properly timed (to avoid back fire), there are no short circuits, all electrical connections are in order, and there are no leaks in the fuel system.**

**10. Sparks from static electricity are always a hazard when you pour or pump gasoline from one container to another. To preclude the possibility of such sparks during filling operations, a wire bond should be provided between the storage container and the container being filled. In addition, it is advisable to ground the bonding wire or the receiving container.**

**11. Never use gasoline for cleaning parts. Grease, oil and dirt can be removed from metal parts with nonflammable solutions or high flash paint solvents. All solvents and solutions should be used in special degreasing tanks and with adequate ventilating facilities.**

**12. Do not wash hands and arms in gasoline. Dermatitis may result because gasoline takes the natural oil out of skin. Many soaps are available which will remove greasy dirt.**

**13. Do not wear oil or gasoline soaked clothing in the shop. A spark, a hot exhaust manifold or an open flame can easily ignite such clothing.**

**14. Dispose of oil or gasoline rags, waste, etc. in self closing air tight metal containers provided for this purpose. Contents of storage containers should be disposed of daily.**

**15. Using gasoline to remove oil and grease from the floor is prohibited. Spilled gasoline is a fire hazard and should be removed immediately.**

**16. Wipe up any spilled oil, grease or other liquids at once. They are slipping hazards, use oil absorbent materials on the oily spots.**

**17. Keep hands and arms away from sharp and rough edges of the vehicle while lubricating the vehicle.**

**18. Never put hands in front of a grease gun nozzle when the handle is pulled. High pressure grease guns can force grease under the skin.**

**19. All lubricants should be stored in containers with lids and kept in a fireproof room when not in use.**

**20. Be careful not to inhale sprayed or atomized oil. Wait until the oil has settled before resuming work on the car. Do not spray oil toward other workers.**

### **Lifting Devices and Working Under A Vehicle**

**1. Little lifting is required in the modern auto shop. Most lifting is done with hoists, jacks and other lifting devices. In the use of this equipment, know and follow the safe practices involved. If lifting is required, lift with the legs not the back and get help for heavy and/or bulky objects.**

**2. An approved hoist should be used for all work under a vehicle.**

**3. Never crawl or work under a car that is not blocked up. This precaution should be followed even for inspection. Jack stands are provided for holding the car up after it has been raised by a jack. Remember jacks are for raising the car only; they are not to be used for holding the car up.**

**4. Follow these precautions when working under cars:**

- a. Use a creeper**
- b. Keep legs clear of passageways**
- c. Close car doors.**
- d. Do not place tools and equipment on the car above the worker.**
- e. Prohibit other persons working on top of the car.**
- f. Protect eyes with safety glasses, goggles, or face shield.**

**5. Creepers, tools or other equipment should not be left where anyone can step on or trip over them.**

**6. Fasten chain hoists securely and do not overload chain slings. Inspect chain hoists before using; test by lifting only a short distance. Do not use a jack if there is any doubt about its safe operating condition.**

- 7. When two wheels are off the floor, block the other wheels.**
- 8. Never lift or lower a car if someone is working under it.**
- 9. Turn or remove jack handles so that no one can trip over them.**
- 10. Do not lean over a jack handle or a handle socket under load.**
- 11. Operate hydraulic, pneumatic or electric power car hoists strictly according to manufacturer's instructions and do not raise weights beyond the rated capacity of the hoist. The instructor should always inspect the contact of the car with the hoist and he should be in attendance during the lifting operation.**
- 12. Before a car is raised on a drive or type hoist, set brakes, block wheels and check to see that the car is not in gear.**
- 13. Do not rock a vehicle on a hoist unless it is designed for that purpose.**
- 14. Use all safety devices provided on a hoist and see that everyone is in the clear before lowering the hoist.**

### **Electrical Equipment**

**Use extension cords and sockets that are in good condition. Portable lights should be protected by a rubber or neoprene covered steel guard. If the steel guard is not covered with this material, be careful, the guard can become very hot after the bulb has burned for awhile. Do not place cords or wires where they become tripping hazards. Certain portable cords and lights are suspended from the ceiling to prevent this from happening. Make sure that all portable electric tools are grounded with a third wire and that the power cords on portable tools are in good condition.**

### **Tools**

**Instruction about the proper use of power tools or equipment will be given prior to use. Be sure transmission guards and point of operation guards are in place before using power machinery. Defective tools and equipment should be reported to the instructor immediately. Mushroomed chisels and draft pins, hammers with broken handles, defective screw drivers, spread wrenches and greasy tools can cause serious accidents. KEEP THE SHOP AND ALL TOOLS CLEAN AND FREE OF GREASE.**

### **Engines**

- 1. Burns may result from working on a car that has not cooled off. Most frequently these are caused by coming in contact with the manifold, exhaust system, or radiator coolant.**

**2. Engines should be operated only under the immediate supervision of the instructor and only if the shop is equipped for removing exhaust fumes.**

**3. When starting an engine, do not pour gasoline in the carburetor.**

**4. Before starting the engine, make sure the car is out of gear and the wheels are blocked. In cars with automatic transmissions, make sure the shifting lever is in the neutral or park position. Always check to see that tools have not been left on the engine.**

**5. Be especially cautious around moving parts; flywheels, fan blades, fan belts, gears and pulleys. Keep sleeves rolled up when working on any moving machinery. Do not attempt to oil or wipe moving parts of the engine.**

**6. To avoid burns from accidental short circuits and to prevent accidental engagement of the starter, be sure to disconnect the battery before working on the power plant of the car.**

**7. When using an engine analyzer or other testing equipment, always make your connections before starting the engine. Attempting to attach connections while the engine is running is a dangerous practice and may cause serious injury because of all the moving parts.**

**8. Never consider a job complete until you check to make sure all lock washers, cotter pins, or locking devices are in place. Be sure cotter pin ends do not protrude to cause cuts or scratches.**

**Remember, just reading rules is not enough to prevent you from having an accident. Read them and KNOW them. The proper and safe way to do a job is the only way to do that job. The knowledge of how to prevent injury to yourself or others is an integral part of knowing how any operation is performed.**

Equal Employment Opportunity CASE is a WIA Title I- financially assisted program and is therefore an equal opportunity employer/ program which provides auxiliary aids and services upon request to individuals with disabilities by calling 711 or 800.648.3458 TTY. US Department of Labor The CASE grant project (\$18,679,289) is 100% funded through the US Department of Labor's Trade Adjustment Assistance Community College and Career Training program. DOL Attribution This workforce solution was funded by a grant awarded by the US Department of Labor's Employment and Training Administration. The solution was created by the grantee and does not necessarily reflect the official position of the US Department of Labor. The Department of Labor makes no guarantees, warranties or assurances of any kind, express or implied, with respect to such information, including any information on linked sites and including, but not limited to, accuracy of the information or its completeness, timeliness, usefulness, adequacy, continued availability or ownership.

This work is licensed under a Creative Commons Attribution 4.0 International License.



# Task to be completed-Compression test.

**Toyota Prius**

name \_\_\_\_\_

List any precautions below before performing compression test.

---

---

---

List all required tools to perform compression test.

---

---

List below the compression reading for one cylinder.

\_\_\_\_\_ psi.

What is the compression specification for this engine?

\_\_\_\_\_ psi.

What is the allowable pressure differential from highest to lowest compression readings?

\_\_\_\_\_ psi.

Is there any possible way to perform a relative compression test on this vehicle?

---

---

## Task to be completed-Inverter cooling system service.

**Toyota Prius**

name\_\_\_\_\_

List any precautions before performing inverter cooling system service.

---

---

---

List any special tool required to perform service.

---

---

What is the torque specification for the drain plug?

\_\_\_\_\_ ft. lbs.

Where is the inverter coolant drain plug located?

---

How do you ensure that all the air is purged from the inverter system?

---

---

---

What type of coolant should be used in this system?

---





# Task to be completed-Compression test.

## 2011 Chevrolet Volt

List any precautions below before performing compression test.

---

---

---

List all required tools to perform compression test.

---

---

What is the first required step in order to perform a compression test after the vehicle is pulled into the service bay?

---

If the theft deterrent system becomes active and does not allow the engine to crank, how do you reset it?

---

List below the compression reading for one cylinder.

\_\_\_\_\_ psi.

What is the compression specification for this engine?

\_\_\_\_\_ psi.

What is the allowable pressure differential from highest to lowest compression readings?

\_\_\_\_\_ psi.

Is there any possible way to perform a relative compression test on this vehicle?

---

---



# Check Sheet for UYV 32 hands-on Training

# Prius Gen I

Team name \_\_\_\_\_

	<b>Action</b>	<b>Note</b>	<b>Done</b>
1	Locate Service Plug and Fuse		
2	Locate Vacuum Valve on Exhaust. What is it for?		
3	Locate READY light		
4	Find the Turtle light		
5	Locate Inverter Pump		
6	12 volt CCA. What is the spec?		
7	Do a Gas Gauge reset of the inclinators		
8	Locate Resolver connector MGI / MG2		
9	Locate Drain and Fill for CVT		
10	Use Mastertech .. CAN?		
11	Re set the Maintenance light		
12	Locate DC-DC converter		
13	Locate components of Brake-by-wire		
14	Locate Inverter for MG1 and MG2		
15	Remove one ignition coils or Injector and listen to CVT rattle while running		
16	Install bad MAF and drive car		

17			

# Hybrid and Alternative Fuel Vehicles

## Instructor's Resource Manual

### Chapter 1

### Carbon-Based Fuels and the Environment

#### Chapter Summary

1. Hybrid electric vehicles (HEVs) are capable of providing better fuel economy than a comparable size vehicle that uses an internal combustion engine (ICE) alone.
2. Today's society is based on the use of carbon-based fuels, which are made from the remains of living plants and animals.
3. Carbon atoms are attached to hydrogen atoms to form hydrocarbons, abbreviated HC.
4. The Clean Air Act (CAA) was created to establish standards to protect public health. The CAA established the Environmental Protection Agency (EPA), which in turn established emission standards.
5. Anthropogenic (man-made) greenhouse gases are causing an increase in the concentration of CO<sub>2</sub> in the atmosphere.
6. The Kyoto Protocol calls for countries to voluntarily reduce the formation of greenhouse gasses by at least 5% below 1990 levels. To help reduce the generation of greenhouse gasses, reduce the total amount of fuel burned.
7. Global warming is thought to be occurring and is likely caused by the increased production of greenhouse gasses.

---

#### Key Terms

AT-PZEV 4 \* Bin Number 4 \* CAA 3 \* CARB 3 \* Carbohydrates 1 \* Carbon 1 \* Carbon Dioxide 2 \* Carbon Footprint 9 \* Carbon Monoxide 2 \* EPA 3 \* Global warming 11 \* Greenhouse Gas (GHG) 7 \* Hydrocarbons 2 \* ILEV 4 \* IPCC 7 \* Irradiance 6 \* Kyoto Protocol 7 \* LEV 3 \* Nitrogen 2 \* NLEV 4 \* ODS 8 \* Organic 1 \* Oxygen 2 \* Ozone 6 \* Peak Oil 10 \* pH 9 \* PZEV 4 \* Smog 2 \* Soot 3 \* Stratosphere 6 \* SULEV 3 \* Tier 3 \*

TLEV 3 \* Troposphere 6 \* ULEV II 3 \* Ultraviolet (UV) radiation 6 \* UVA 6 \* UVB 6 \* UVC 6 \* VOC 8 \* ZEV 4

## **Objectives**

1. Describe the role of hybrid and alternative fuel vehicles in today's society: reference (Page 1 )
2. Identify carbon-based fuels: reference (Page 1)
3. Describe how organic materials decompose into carbon-based fuels: reference (Page 1)
4. Explain the difference between carbon-based and non-carbon based energy: sources reference (Page 1)
5. Explain the federal and California Air resources Board emission standards: reference(Pages 4-5)
6. List Alternative to carbon-based fuels reference (Page 2)
7. List the factors that will be needed to reduce the carbon footprint: reference (Pages 10)

## **Lecture Resources:**

### **Additional Topics:**

How biodiesel Fuel Works (Page 2)

Search the Internet

Website: <http://auto.howstuffworks.com/fuel-efficiency/alternative-fuels/biodiesel.htm>

Ethanol Fuel (Page 2)

Search the Internet

Website: <http://video.answers.com/alternative-fuel-ethanol-production-516992857>

History of the Clean Air Act (Page 3)

Search the Internet

Website: [http://epa.gov/oar/caa/caa\\_history.html](http://epa.gov/oar/caa/caa_history.html)

OZONE (Page 10)

Search the Internet

Website: <http://www.epa.gov/ozone/>

Health Effects of Air pollution (Page 11)

Search the Internet

Website: <http://www.lbl.gov/Education/ELSI/Frames/pollution-health-effects-f.html>

KYOTO PROTOCOL (Page 8)

Search the Internet

Website: [http://unfccc.int/kyoto\\_protocol/items/2830.php](http://unfccc.int/kyoto_protocol/items/2830.php)

Acid Rain (Page 9)

Search the Internet

Website: <http://epa.gov/acidrain/effects/health.html>

Carbon Footprint (Page 13)

Search the Internet

Website: [http://www.footprintnetwork.org/en/index.php/GFN/page/carbon\\_footprint/](http://www.footprintnetwork.org/en/index.php/GFN/page/carbon_footprint/)

How the Hydrogen Economy Works (Page 15)

Search the Internet

Website: <http://auto.howstuffworks.com/fuel-efficiency/fuel-economy/hydrogen-economy.htm>

## **Discuss**

1. Ask students to discuss the emissions ratings used to categorize Tier 2 vehicle types under the Clean Air Act Amendments (CAAA) of 1990. Ask them to identify a ULEV and a ZEV vehicle. Students may use the Internet to determine which vehicles fall into these categories. (Pages 3)
2. Ask students to talk about the federal EPA Bin Number and its significance in terms of tailpipe emissions. Ask students to identify Bin 3 and Bin 10 vehicles currently on the market reference (Page 5)
3. Discuss how the two levels of Ozone affect human health and the planet reference (Page 8)

## Demonstrate

1. Show students the location of the vehicle emissions control information (VECI) label under the hood of a vehicle, and discuss the types of information it provides to the service technician. (Page 4)
2. Show students an example of a calibration code on a controller case. What is the significance of these codes? (Page 4)

## Student Activities

1. MAL: None, we should create some for MAL

## Review Questions / Answers

1. What is the purpose or the need for hybrid electric vehicles in today's society? (Text page 1)

**The purpose or need for hybrid electric vehicles is to reduce the use of oil and reduce emissions.**

2. What is meant by the term "carbon-based society?" (Text page 1)

**A carbon-based society means that most power comes from carbon-based fuels, such as coal and gasoline, which all started as organic living plants and animals.**

3. What are hydrocarbons? List eight hydrocarbons. (Text page 2)

**Hydrocarbons are molecules which contain both hydrogen and carbon. Eight common hydrocarbons include: methane, ethane, propane, butane, pentane, hexane, heptane, and octane.**

4. What are the meanings of the following terms: TLEV, LEV, ULEV, SULEV, ZEV, NLEV, PZEV, and AT-PZEV? (Text pages 3-4)

**TLEV – transitional low-emission vehicle**

**LEV – low-emission vehicle**

**ULEV – ultra low-emission vehicle**

**SULEV – super ultra low-emission vehicle**

**ZEV – zero-emission vehicle**

**PZEV – partial zero-emission vehicle**

**AT-PZEV – advanced technology partial zero-emission vehicle**

5. Which type of ultraviolet radiation is the most harmful to living organisms on earth? (Text page 6)

**UVB**

6. What are six things that people can do to reduce their individual carbon footprint? (Text page 10)

**1) Turn off electrical devices when not in use**

**2) Turn down central heating 1 or 2 degrees**

**3) Drive less**

**4) Carpool**

**5) Use compact florescent bulbs instead of incandescent**

**6) Replace older appliances with new more efficient units**

**CHAPTER QUIZ QUESTIONS AND ANSWERS:**

1. The major greenhouse gas from gasoline-powered vehicles is \_\_\_\_\_. (Text page 9)

a. Carbon monoxide (CO)

**b. Carbon dioxide (CO<sub>2</sub>) x**

c. Oxides of nitrogen (NO<sub>x</sub>)

d. Unburned hydrocarbons (HCs)

2. Particulate matter (PM) is also called \_\_\_\_\_. (Text page 8)

**a. Soot x**

b. HC

c. CO<sub>2</sub>

d. Smog

3. The earth's atmosphere contains \_\_\_\_\_ ; \_\_\_\_\_. (Text page 2)



- a. 78% hydrogen; 21% oxygen
  - b. 21% nitrogen; 78% oxygen
  - c. 78% nitrogen; 21% oxygen     x**
  - d. 21% inert gases; 78% oxygen
4. Which hydrocarbon (HC) molecule contains seven carbon atoms? (Text page 2)
- a. Methane
  - b. Ethane
  - c. Pentane
  - d. Heptane     x**
5. Which of the following result in smog when exposed to sunlight? (Text pages 2-3)
- a. Unburned hydrocarbon (HC)
  - b. Oxides of nitrogen (NO<sub>x</sub>)
  - c. Carbon dioxide (CO<sub>2</sub>)
  - d. Both a and b     x**
6. Which of the California emission standards has the tightest requirements? (Text page 5)
- a. SULEV     x**
  - b. ULEV
  - c. LEV
  - d. TLEV
7. Which of the following ultraviolet radiation types is the most harmful to living organisms? (Text page 6)
- a. UVA
  - b. UVB     x**
  - c. UVC

- d. None of the above
8. Why is sunburn more likely to occur at high altitudes as compared to sea level? (Text page 8)
- a. **There is less ozone above to block the UV rays**     **x**
  - b. You are closer to the sun
  - c. There is less oxygen
  - d. It is colder at high altitudes and sunburn is therefore less likely
9. To reduce your carbon footprint, what action(s) can be performed? (Text page 10)
- a. Drive a hybrid electric vehicle instead of a conventional gasoline-engine vehicle.
  - b. Drive fewer miles.
  - c. Insulate homes.
  - d. **All of the above**     **x**
10. Peak oil means \_\_\_\_\_. (Text page 10)
- a. The oil that is closest to the surface of the earth
  - b. **When worldwide oil production peaks and then starts to decline**   **x**
  - c. When the use of oil peaks and starts to decline
  - d. Good crude oil that burns without creating greenhouse gases

## ASE / NATEF Correlation Charts

### Suggestions for related instruction (web links / books / movies / etc.)

1. <http://www.automotto.com/entry/rechargeable-car-batteries/>
2. <http://www.autoresearchanddesign.com/>
3. <http://www.nrel.gov/hydrogen/>
4. <http://voices.yahoo.com/vehicle-fuel-economy-outlook-till-2025-10597657.html?cat=15>
5. <http://www.earthobservatory.nasa.gov/Features/UVB/>

6. <http://carbonatedseltzer.com/carbonated-seltzer-links/salty-taste-of-homemade-soda-water/>

# Chapter 2

## Introduction to Hybrid Vehicles

### Chapter Summary

1. Hybrids use two different power sources to propel the vehicle.
2. A mild hybrid with a lower voltage system (36-50 volts) is capable of increasing fuel economy and reducing exhaust emissions but is not capable of using the electric motor alone to propel the vehicle.
3. A medium hybrid uses a higher voltage than a mild hybrid (140-150 volts) and offers increased fuel economy over a mild hybrid design but is not capable of operating using the electric motor alone.
4. A full or strong hybrid uses a high-voltage system (250-650 volts) and is capable of operating using the electric motor(s) alone and achieves the highest fuel economy improvement of all types of hybrids.
5. Early in vehicle history, electric vehicles were more popular than either steam- or gasoline-powered vehicles.
6. Legislation passes in California in 1998, which mandated zero-emission vehicles (ZEVs), caused the vehicle manufacturers to start producing electric vehicles. When the law was changed to allow the substitution of other vehicles that produced lower emissions, but not zero, it helped promote the introduction of hybrid electric vehicles (HEVs).
7. A hybrid vehicle is defined as having two power sources to propel the vehicle.
8. Electric motors are perfect for vehicle use because they produce torque at low speed, whereas internal combustion engines need to have an increase speed before they produce maximum power and torque.

---

### Key Terms

• Assist hybrid 22 • BAS 19 • BEV 14 • EV 14 • Full hybrid 22 • HEV 14 • HOV lane 20 • Hybrid 21 • ICE 14 • Idle stop mode 21 • Medium hybrid 22 • Micro-hybrid drive 20 • Mild hybrid 21 • Motoring mode 19 • Parallel-hybrid design 17 • Power-assist mode 21 • Quiet mode 21 • Series-hybrid design 16 • Series-parallel hybrid 18 • Strong hybrid 22 • ZEV 15

## Objectives

1. Describe the different types of hybrid electric vehicles. (Pages 16-20)
2. Explain how a hybrid vehicle is able to achieve an improvement in fuel economy compared to a conventional vehicle design. (Page 20)
3. Discuss the advantages and disadvantages of the various hybrid designs. (Page 21)
4. Describe HEV components, including motors, energy sources, and motor controllers. (Pages 16, 17, and 18)
5. Discuss the operation of a typical hybrid electric vehicle. (Page 16)

## Lecture Resources:

### Search the Internet

1. Have the students use the Internet to research current hybrid vehicles that are being sold. Ask students to select on vehicle and provide information about it, including why the vehicle is classified as a hybrid. Have them share their findings with the class. (Page 14)
2. Have the student's research details of the California ZEV mandate. Ask them to identify current ZEV vehicles that are available and to share their findings with the class. (Page 15)
3. The cost of a hybrid or ZEV vehicle will be higher than that of a conventional vehicle. Have the students use the Internet to determine the average cost of hybrid and/or ZEV vehicles and discover any tax rebates or other cost benefits available as a result of their purchase. Ask students to share their findings with the class. [http://www.fueleconomy.gov/feg/tax\\_hybrid.shtml](http://www.fueleconomy.gov/feg/tax_hybrid.shtml) (Page 16)
4. Have the students use the Internet to identify alternative power supplies-independent and/or self-sustaining-that can support heating and air conditioning systems in hybrid vehicles. Have students create a chart that depicts the alternate sources and share their work with the class. (Page 17)
5. Have the students search the Internet to identify suppliers of BAS conversion systems. Are there any available? Have them share and discuss their findings as a class. (Page 18)

6. Have the students use the Internet to find information on micro-hybrid-drive systems. How common is their use? What is the cost? Have students share their findings in a class discussion (Page 19)

### **Additional Topics:**

Driving and Owning a hybrid electric Vehicle (Page 16)

Search the Internet

<http://www.hybridcars.com/mileage-stories/driving-habits.html>

Classifications of hybrid electric vehicles (Page 17)

Search the Internet

<http://www.articlesnatch.com/Article/Classifications-Of-Hybrid-Electric-Vehicles/3656156>

Belt alternator starter system (Page 19)

Search the Internet

<http://www.hybridcars.com/types-systems/belt-alternator-starters.html>

Common features of most hybrids (Page 21)

Search the Internet

<http://www.fueleconomy.gov/feg/hybridtech.shtml>

### **Discuss**

1. Ask the students to discuss the evolution of automobiles. Have them share how automobiles have changed over time. What advances will future vehicles have? (Page 14)
2. Review with students the different methods of propulsion. What two common combinations are being used to classify vehicles as hybrids? (Page 14)
3. Review the basic principles of Ohm's law: 1 volt is required to push 1 ampere through 1 ohm of resistance; therefore, if the voltage is doubled, then the number of amperes of current flowing through a circuit will also double if the resistance of the circuit remains the same. How does Ohm's law apply to electric vehicles? (Page 14)
4. **SAFETY**- Remind students to use insulated tools when working on vehicles that use high voltage. (Page 16)

5. Gather information about the newest ZEV vehicles available. Ask students to identify the current benefits, problems, and future of these vehicles. (Page 16)
6. Have the students consider the benefits or drawbacks concerning the cost of a vehicle versus fuel savings. How long will you need to drive a vehicle with fuel savings in order to offset its extra cost as compared to driving an internal combustion engine vehicle? (Page 16)
7. Show the Students the charge port for a hybrid electric vehicle. Discuss the procedure involved with recharging along with the electrical requirements of a charging facility. (Page 16)
8. Have the students compare and contrast components of series and parallel hybrid vehicles, referring to Figures 2-4 through 2-6. Ask students to identify the pros and cons of the components. (Pages 17-18)
9. Have the students identify other fuels that can replace diesel fuel. How will these alternate fuels help reduce fuel cost? (Page 17)
10. **Environment-** Are there better ways to create the electricity required to charge hybrid electric vehicles without using standard power plants? Most power plants create harmful emissions, so using this to supply of electricity may reduce or negate the purposes of using hybrid electric vehicles. Ask students to share their thoughts on this issue. (Page 17)
11. Review idle stop mode with the students and highlight the difference between a conventional starter and a voltage motor generator. (Page 18)
12. Have students talk about belt alternator starter systems. What are the advantages of BAS system? (Page 19)
13. **Hands-On-** If you have access to a vehicle with a BAS system, have students identify the components of the system, referring to figure 2-9 as needed. (Page 20)
14. Discuss the benefits and drawbacks of a BAS system. Should a vehicle with a BAS system be considered a hybrid vehicle? Can a BAS system be added to a conventional diesel vehicle to help it be considered a full hybrid vehicle? (Page 19)
15. **Hands-On-** If you can obtain a BAS conversion kit, have the class convert a common ICE vehicle into a mild hybrid by adding on a BAS system. This is also an opportunity for students to review safety procedures and electrical principles and develop a better understanding of hybrid vehicles. (Page 20)

16. What is a bidirectional tensioner and what role does it play in a micro-hybrid-drive system? Why does this belt tensioner need to provide tension in both directions? (Page 20)
17. **Environment-** Review the importance of lowering CO<sub>2</sub>. Discuss with students that conversion of nonhybrid vehicles is needed to help lower CO<sub>2</sub> levels. Point out the two features that can move nonhybrid vehicles into the mild hybrid category: idle stop and regenerative brakes. (Page 20)

## Demonstrate

1. Measure amperage and voltage in series and parallel circuits on a vehicle, or a learning aid. Call student's attention to the change in amperes and voltages between series and parallel circuits. (Page 16)
2. Start a hybrid vehicle with students. Have them compare and contrast this start with a combustion engine vehicle start. Ask students to discuss the differences between the two starts. (Page 16)
3. While a hybrid engine is in idle stop mode, connect a five gas analyzer. Have students take note of the CO<sub>2</sub> reading to confirm zero or low CO<sub>2</sub> levels in idle stop mode. Next connect a five-gas analyzer to an ICE and compare CO<sub>2</sub> readings at idle. Have students discuss the results. (Page 20)

## Student Activities

1. MAL- Chapter 18.1 Activity Label HEV1 (Page 15)
2. MAL-Chapter 39 NATEF Sheet Electrical Circuit (Page 16)
3. MAL-Chapter 39 NATEF Sheet Series circuit work sheet #1 (Page 16)
4. MAL-Chapter 39 NATEF Sheet Series circuit work sheet #2 (Page 16)
5. MAL-Chapter 39 NATEF Sheet Parallel circuit work sheet #1 (Page 16)
6. MAL-Chapter 39 NATEF Sheet Parallel circuit work sheet #2 (Page 16)
7. MAL- Chapter 14 NATEF Sheet Math Problem excise (Page 16)
8. MAL-Chapter 10 Diagnostic Assessment "Stop Safely Now Warning light Concern" (Page 16)
9. MAL- Chapter 89.1 Activity: Label HEV components. (Page 19)
10. MAL- Chapter 18 Review questions 18.1, 18.2, 18.3, 19.1

## Review Questions / Answers

1. What are the advantages and disadvantages of a series hybrid design? (Text page 17)  
**A series hybrid uses the electric motor to propel the vehicle which sometimes results in a less**



**complex powertrain. However, to maintain the battery charge, using an ICE to charge the batteries adds to the weight and complexity of the vehicle.**

2. What type of hybrid electrical vehicle is a Toyota Prius and Ford Escape hybrid? (Text page 18)  
**Both are considered to be a series-parallel design hybrid because they are able to operate and propel the vehicle using battery power alone even if they can do so for a limited distance.**
  
3. What are the advantages and disadvantages of mild, medium, and full hybrid vehicles? (Text pages 21-22)  
**Mild and medium hybrids cost less than full (strong) hybrids. Mild hybrids are the least expensive to manufacture but also provide the least improvement in fuel economy. Full hybrids cost more, but deliver greater fuel savings.**
  
4. Why does a BAS system cost less than the other types of hybrid vehicles? (Text pages 19-21)  
**A belt alternator starter (BAS) system cost less because there does not need to be a connection between the engine and the transmission as is needed on other types of hybrids.**
  
5. What are the four modes of operation of a typical hybrid vehicle? (Text page 21)  
**The four modes of operation of a typical hybrid electric vehicle include: idle stop, regenerative braking, power assist, and electric vehicle mode (full hybrid only).**

#### **CHAPTER QUIZ QUESTIONS AND ANSWERS:**

1. The GM EV1 was what type of vehicle? (Text page 15)
  - a. **Totally electric powered X**
  - b. A first-generation hybrid electric vehicle (HEV)
  - c. A series-type HEV
  - d. A parallel-type HEV
  
2. Which type of hybrid uses 36 to 42 volts? (Text pages 21-22)
  - a. **Mild hybrid X**
  - b. Medium hybrid
  - c. Full hybrid
  - d. Strong hybrid
  
3. Which type of hybrid is capable of propelling the vehicle using just the electric motor? (Text page 22)

- a. BAS type
  - b. Strong (full) hybrid X**
  - c. Medium hybrid
  - d. Mild hybrid
4. About how fast does a motor-generator crank the internal combustion engine? (Text page 17)
- a. About 1,000 RPM X**
  - b. About 2,000 RPM
  - c. About 150-300 RPM
  - d. About 400-600 RPM
5. Which type of hybrid electric design is costs the least? (Text page 19)
- a. Strong hybrid design
  - b. Series hybrid design
  - c. Parallel hybrid design
  - d. BAS design X**
  - e.
6. Which type of hybrid electric vehicle has idle stop operation? (Text page 21)
- a. Strong hybrids only
  - b. Strong, mild, and medium hybrids X**
  - c. Mild hybrids only
  - d. Medium hybrids only
7. Technician A says that most hybrids require that they be plugged into an electrical outlet at night to provide the electrical power to help propel the vehicle. Technician B says that the internal combustion engine in an HEV will often stop running when the vehicle is stopped. Which technician is correct? (Text page 16)
- a. Technician A only
  - b. Technician B only X**
  - c. Both Technicians A and B
  - d. Neither Technician A nor B
8. Technician A says that most hybrids use the series hybrid design. Technician B says that most hybrids have 42-volt batteries. Which technician is correct? (Text pages 16-18; 22)
- a. Technician A only
  - b. Technician B only
  - c. Both Technicians A and B

d. Neither Technician A nor B X

9. Electric motors are better than an internal combustion engine to propel a vehicle because\_\_\_\_\_.  
(Text page 22)

- a. They produce high torque at low speeds
- b. They do not burn fuel and therefore do not release carbon dioxide into the environment
- c. They are quiet
- d. **All of the above are correct X**

10. All of the following are characteristic of a hybrid electric vehicle (HEV), **except** \_\_\_\_\_. (Text page 16)

- a. High voltages (safety issue)
- b. **Lower fuel economy X**
- c. Lower amount of carbon dioxide released to the atmosphere
- d. Quiet

## ASE / NATEF Correlation Charts

### Suggestions for related instruction (web links / books / movies / etc.)

1. <http://voices.yahoo.com/vehicle-fuel-economy-outlook-till-2025-10597657.html?cat=15>
2. <http://www.brighthub.com/engineering/mechanical/articles/2267.aspx>
3. <http://www.kele.com/templates/content.aspx?id=4717>
4. <http://www.hybridcars.com/types-systems/belt-alternator-starters.html>
5. <http://www.hybridcars.com/suvs-minivans/ford-escape-hybrid-overview.html>

# Chapter 3

## Hybrid Engine Systems

### Chapter Summary

1. The four strokes of the four-stroke cycle are intake, compression, power, and exhaust.
2. Engines are classified by number and arrangement of cylinders and by number and location of valves and camshafts, as well as by type of mounting, fuel used, cooling method, and induction pressure.
3. Engine size is called displacement and represents the volume displacement or swept by all of the pistons.
4. Engine power is expressed in horsepower, which is a calculated value based on the amount of torque or twisting force the engine produces.
5. The Atkinson cycle is used on most hybrid engines due to its greater efficiency.
6. Many inline hybrid engines use an offset crankshaft and low-friction pistons to reduce internal friction.
7. All hybrid engines use coil-on-plug ignition systems and the Honda Insight uses indexed spark plugs.
8. All hybrid engines use electronically controlled port fuel injection and some use gasoline direct injection
9. Most hybrid electric vehicle use a wide-band oxygen sensor to help the engine achieve the lowest possible exhaust emissions.

### Key Terms

• 720° cycle 26 • ACM 36 • Active fuel management 35 • ANC 36 • APP 38 • APS 38 • Atkinson cycle 26 • BHP 29 • Compression ratio (CR) 28 • COP 37 • Cylinder deactivation 35 • Displacement 27 • Drive-by-wire 38 • Electronic throttle control (ETC) 38 • EMI 37 • ERFS 43 • Four-stroke cycle 24 • GDI 45 • Horsepower 29 • ICE 24 • Major thrust surface 29 • Miller cycle 26 • MRFS 43 • Nernst cell 40 • Offset crankshaft 31 • Power 29 • Pumping losses 27 • PVV 44 • Servomotor 38 • TDC 24 • Torque 28 • VTEC 35 • Wide-band oxygen sensor 39 • Work 29

### Objectives

1. Explain how a four-stroke-cycle gasoline engine operates. (Page 24)

2. Explain the Atkinson cycle and how it affects engine efficiency. (Page 26)
3. List the various methods by which vehicle engines are classified and measured. (Page 27)
4. Describe the importance of using the specified oil in the engine of a hybrid-electric vehicle. (Page 37)
5. Describe how the fuel injection and ignition systems work on hybrid gasoline engines. (Pages 39-37)
6. Explain how active control engine mounts function. (Page 37)
7. Describe how wide-band oxygen sensors work. (Page 39)
8. Explain how variable valve timing is able to improve engine power and reduce exhaust emissions (Page 31)

## **Lecture Resources:**

### Search the Internet

1. Have the students search the Internet to find out the difference between a four-stroke engine and a two-stroke engine. (Page 24)
2. Have the students research the Internet and determine the advantage of an overhead valve engine design as opposed to a push-rod design. (page 26)
3. Ask the students to research the Internet and determine what the function of SAE is. (Page 27)
4. Have the students use the Internet to research why offsetting the pin will maximize engine efficiency. Have them share their results with the class. (Page 30)
5. Have the students research the Internet and discover the benefits of variable valve timing. Have them discuss their findings in class. (Page 31)
6. Have students search the Internet and discover the benefits of variable valve timing. Have them discuss their findings in class. (Page 32)
7. Have the students search the Internet to find out the advantages of variable valve timing. Have them share their findings in class, (Page 33)
8. Have the students search the Internet for various types of cylinder deactivation systems that are used. Have them discuss their findings in class. (Page 34)

9. Have the students search the Internet to find out which modern production automobile was the first to offer multiple cylinder deactivations. Have them share their findings in class. (Page 35)
10. Have the students search the Internet for information on the difference between Group II, Group III, Group IV, and Group V base oils. Have the students compare flash point, pour point, and so on. Ask them to write a report on their findings. (Page 36)
11. Have the students use the Internet to search platinum spark plugs. What are their advantages? What is the cost comparison of regular and platinum spark plugs? Ask students to create a comparison list to share with the class. (Page 38)
12. Have the students use the Internet to research uses of zirconia-based electrolyte materials. Why are these materials used? What are their benefits? Ask students to share their findings with the class. (Page 39)
13. Have the students use the Internet to research the cost of zirconia and Titania oxygen sensors. Is one type more expensive than the other? What would account for the cost of each? Have students present their findings to the class. (Page 40)
14. Have the students use the Internet to determine how many vehicle manufacturers use wide-band oxygen sensors. Have students make a list of manufacturers and share their findings with the class. (Page 41)
15. Have the students write a paper on the different types of oxygen sensors. Have them describe construction, materials, and operating characteristics. Also, have them describe testing procedures for each type of sensor. Grade students' papers on content and accuracy. (Page 42)
16. Have the students' research the Internet for vehicles with direct-injection systems and manufacturers that offer them. Have them make a list of manufacturers and include key points about the systems. Ask students to share their findings with the class. (Page 43)
17. Have the students' research fuel rails on the Internet. Have them check for manufacturers' recalls. Have them list their findings and share them with the class. (Page 44)
18. Have the students use the Internet to research products that claim to clean fuel injectors and reduce deposits. Are these products effective? Ask students to report their findings to the class. (Page 45)

**ASSESS-** Grade the students on their ability to correctly describe the for-stroke engine cycle. (Page 25)

**CROSS Curricular Activity: MATH** Have students find the formula for calculating the volume of a cylinder and then calculate the volume. (Page 28)

**ASSESS-** Have students write a brief report comparing torque and horsepower, using mathematic examples to explain the difference. Grade the information for correctness. (Page 29)

**CROSS Curricular Activity: Science** Have the students research the properties and uses of Zirconium oxide. Are there other materials that can produce voltage in the presence of oxygen? Ask students to report their findings to the class. (Page 42)

**ASSESS** Have the students describe the speed-density and mass airflow fuel-injection systems. Ask them to compare and contrast the two systems. Grade them on their understanding of the systems and their ability to differentiate them. (Page 33)

**ASSESS-** Have the students draw wiring diagrams of two-primary-wire and three-primary-wire COP ignition system. Grade them on the accuracy of their wiring diagrams. (Page 37)

**ASSESS** Have the students explain electronic and mechanical returnless fuel systems. Have them compare and contrast the systems. Grade students on their understanding of each system as well as of similarities and differences. (Page 45)

### **Additional Topics:**

Hybrid Internal Combustion Engine (ICE) (Page 24)

Search the Internet

<http://www.hybrid-vehicle.org/hybrid-vehicle-ice.html>

Atkinson Cycle (Page 26)

Search the Internet

<http://www.animatedengines.com/atkinson.html>

Pumping Losses (Page 26)

Search the Internet

<http://www.sesusa.org/Drlz/pumping.html>

## Discuss

1. Ask the students to explain the four-stroke cycle operation (Page 24)
2. Ask the students to discuss why an 8-cylinder engine will operate more smoothly than a 4-cylinder engine. (Page 24)
3. Ask students what is drawn into the cylinder in a typical nondirect fuel injected engine. (Answer: Fuel and air). (Page 25)
4. **TIP-** Many newer engines are using direct injection due to its approximately 10% efficient increase. (Page 25)
5. Ask the students where the camshaft is located in a push-rod engine as opposed to where it is located in an overhead valve engine. (Answer: In the block, and in the head, respectively. (Page 26)
6. Ask the students to explain the difference between an OTTO cycle and a Atkinson cycle. (Page 26)
7. Ask the students to explain Pumping Losses. (Page 26)
8. Ask students to discuss as a class the benefits of the Atkinson cycle over an OTTO cycle for use with hybrid electric vehicle. (Page 27)
9. **Hands-on-** Have the students look up the engine displacement using service information for various vehicles. Since all spec are now metric, have the students calculate the equivalent size in cubic inches. (Page 28)
10. Ask students how a build-up of carbon on top of the piston would affect compression ratio. (Answer: it would increase the compression ratio). (Page 28)
11. **TIP-** While most modern gasoline engines have a compression ratio of 8 to 10:1; diesel engines have a compression ratio of 20 to 22:1. (Page 28)
12. **Hands-on-** Have the students look up the torque specs for various engine fasteners. (Page 29)
13. **Hands-on-** Have the students calculate horsepower based of these RPM and torque specs: 2500RPM/150 lb.ft, 3000RPM/170 lbs.ft, 3500RPM/ 200lb.ft, and 4000PRM/ 225 lb.ft. (Page 28)
14. **Hands-on-** Have student take answers from last hands-on and calculate horsepower loss at 6000 feet above sea level. (Page 28)



15. Ask Students to discuss how the piston and rod assembly function together and how their reciprocating motion is turned into rotary motion. (Page 30)
16. Have the students discuss the purpose of the different parts of the piston assembly and why they are important to the overall performance of the internal Combustion engine (ICE). (Page 30)
17. Ask the students what advantages the overhead camshaft has as opposed to the cam-in-block design. (Page 30)
18. **TIP-** Tell the students that connecting rods are not to be mixed during disassembly. (Page 30)
19. **Hands-On-** For a vehicle that uses variable valve timing, have the students use the service information to read a description of the variable valve timing and how it is controlled on that vehicle. (Page 31)
20. **Hans-on-** Have students search service information to determine what controls the camshaft position actuator oil control valve. (Page 32)
21. Ask the students to discuss the advantages of intake and exhaust camshaft phasing (Page 33)
22. **TIP-** the control solenoid screen can become plugged if the oil is not changed regularly. This can cause changes in performance and emissions. (Page 33)
23. **Hands-on-** Have the students use service information to research the VTEC system used by Honda. (Page 34)
24. Show the students an example of a camshaft with excessive lobe wear. (Page 34)
25. **Hands-on-** have the students use service information to determine how the camshaft, camshaft bearings, and lifters receive their lubrication. (Page 34)
26. Ask the students to discuss the main purpose of cylinder deactivation. (Answer: Fuel economy.) (Page 35)
27. **TIP-** When installing new lifters, immerse them in clean oil and pump them up manually to eliminate the air from the lifter. (Page 35)
28. Discuss why manufacturers do not recommend single-viscosity oil in modern engines. Ask students why it was okay for single-viscosity oil to be used in older engines and engines designed for high performance. (Page 36 )

29. **TIP-** The internal combustion engine (ICE) lubrication system absorbs one-third of the heat produced by the engine. (Page 36)
30. Have the students talk about ignition coil operation. What process does an ignition use to produce a high-voltage spark from an ignition coil? (Page 37)
31. Have students talk about the primary and secondary ignition circuits. How do the two circuits function independently and how do they interact? (Page 37)
32. Have the students discuss the construction of an ignition coil. What is at the core of an ignition coil? What is the purpose of the core? (Page 37)
33. Using an ignition system wiring diagram, have the students locate the triggering device. How does this triggering device work? (Page 37)
34. Have the students discuss spark plug heat range and how it affects engine operation and emissions. Is it ever acceptable or beneficial to vary from manufacturers' recommendations? (Page 38)
35. Have the students discuss electronic throttle control systems. What are the components of an electronic throttle control system? How is the accelerator pedal position sensor similar to a throttle position sensor? (Page 38)
36. Ask the students to discuss the normal operation of the electronic throttle control system. How could the lack of rapid response give some drivers a negative opinion of the ETC system? (Page 38)
37. Have the students discuss oxygen sensors. How do O<sub>2</sub> sensors help achieve the correct air-fuel ratio? (Page 39)
38. Have students talk about one, two, three and four wire oxygen sensors. What is the same about these sensors and what is different? (Page 39)
39. Ask the students to discuss the Titania oxygen sensor and its operating characteristics. How is it different from a zirconia sensor? (Page 39)
40. **TIP-** It may be necessary to access tune-up specifications and diagrams to accurately identify bank 1 on different manufactures' V-6 and V-8 engines. (Page 39)
41. Have the students discuss open-loop and closed-loop engine operation. Will an engine that runs well in open loop also run well in closed loop? (Page 40)
42. Have students talk about wide-band oxygen sensors. What does wide-band mean? (Page 40)

43. Explain to the students the operation of conventional oxygen sensors on a 14.7:1 air-fuel ratio. Is this ratio accurate enough? (Page 40)
44. Ask the students discuss the steps for testing a wide-band oxygen sensor. Why is it necessary to check service information first? (Page 41)
45. Have the students discuss single cell wide-band oxygen sensors. How are they similar to other sensors? (Page 42)
46. **TIP-** Explain to the students what a breakout box is. Ask them to decide whether a breakout box would be beneficial in testing dual cell wide-band sensors shown in Figure 3-31. (Page 42)
47. **SAFETY-** Discuss with the students the importance of using proper terminals when testing any sensor, especially when back-probing connectors. Explain that piercing wires that will be exposed to the elements is not an accepted testing procedure. (Page 42)
48. Have students talk about mechanical returnless fuel systems. How are these systems different from electronic returnless systems? What are their limitations? (Page 43)
49. Have the students discuss electronic returnless fuel systems. How is fuel pressure controlled in this system? (Page 43)
50. Have the students discuss the demand delivery system of fuel delivery. How does it differ from other systems of fuel delivery? (Page 44)
51. Have the students discuss the design of fuel injectors. Do injectors that have distinctive spray patterns have to be installed in a specific way? Why are deposit-resistant fuel injectors used in some applications? (Page 44)
52. Have the students talk about the mass airflow fuel-injection system and how it works. How is it different from a speed-density system? (Page 45)
53. Have the students discuss the operation of a gasoline direct-injection system. What are the advantages of this type of injection system? Are the disadvantages enough to limit its use? (Page 45)
54. **TIP-** Explain to the students that exhaust gas recirculation and crankcase ventilation vapors are usually introduced near the throttle blade to be distributed equally among all the cylinders. This combination of hot exhaust and oily vapor can create deposits on fuel injectors, altering or restricting fuel flow. (Page 45)

## Demonstrate

1. Show the students how to determine the bore and stroke of an engine using service information. (Page 28)
2. Show the students how to calculate the cubic inch displacement of an engine given the bore and stroke. (Page 28)
3. Show students examples of various torque wrenches and demonstrate their proper use. (Page 29)
4. Using a demo engine or animation, show the students the operation of the piston in an engine bore. (Page 30)
5. Show the students the different parts of the piston, including the skirt, pin, bore, head valve reliefs, and other components. (Page 30)
6. Show the students how piston pins are not centered on the piston. (Page 30)
7. Using a scan tool and a vehicle equipped with variable valve timing, show the students what variable valve timing data can be observed using the scan tool. (Page 31)
8. Show the students an example of a camshaft position actuator oil control valve (Page 32)
9. Show the students examples of steel and composite camshafts. (Page 33)
10. Show the students a camshaft and point out the intake and exhaust lobes as well as the distributor gear and the fuel pump eccentric. (Page 33 )
11. Using a scan tool, show the students how PWM is used to control the actuator solenoid. (Page 34)
12. Show the students some examples of camshaft position sensors (Page 34)
13. Show students some examples, if available, of cylinder deactivation controls used by various manufacturers. (Page 35)
14. Show the students some examples of solid and hydraulic lifters. (Page 36)
15. On an engine that is equipped with roller lifters, show the students the proper installation of the roller lifter and retaining guides. (Page 36)
16. Show the students a disassembled hydraulic lifter. (Page 36)

17. Review with the students how to use a hand-held oscilloscope, including setup and interpreting waveform patterns. Then show them how to check pickup on an electronic ignition system using an oscilloscope. (Page 37)
18. Using an oscilloscope, show the students the waveform patterns of a magnetic sensor and a hall-effect sensor. (Page37)
19. Show the students' a vehicle with an electronic throttle control system. Point out its components and lack of a throttle cable or linkage. (Page 38)
20. Put an OBD II vehicle on a rack and show students the oxygen sensors. Point out and explain upstream and downstream sensors to them. (Page 39)
21. Show students a conventional O2 sensor that uses zirconium dioxide. (Page 39)
22. Use a scan tool to show the student the bias voltage on a vehicle. Have them watch the data stream when the vehicle is started to see how long it takes the oxygen sensor to override the bias voltage. (Page 40)
23. Show the students the typical locations of oxygen sensors on a vehicle. Show them the number 1, number 2, upstream and downstream sensors if applicable. (Page 40)
24. If available, show the students the data stream readings using a factory scan tool and a generic scan tool. Have them observe the difference in readings, if they are different. (Page 41)
25. Show the students two vehicles, one with port fuel injection and the other with throttle-body fuel injection. Ask students to explain the difference between the two systems. (Page 44)
26. Show the students examples of the round and rectangular cross-section fuel rails. Explain how the rectangular-shaped fuel rail can help control pulsations and noise. (Page 44)
27. Show the students how to use a stethoscope to listen to noise. Have them use the stethoscope to listen to fuel injectors on a running engine. (Page 45)
28. Show the students' examples of fuel injectors, having them note the strainer screen, the seals, and the fuel discharge nozzle. (Page 45)

## Student Activities

1. MAL- Chapter 18.1 Animation Four-Stroke Engine Cycle (Page 24)
2. MAL- Chapter 17 NATEF Sheet Engine oil dipstick test (Page 49)
3. MAL- Chapter 17 NATEF Sheet Engine oil change (Page 49)
4. MAL- Chapter 30 NATEF Sheet Cylinder head specifications (Page 24)
5. MAL-Chapter 31 NATEF Sheet Cylinder head assembly inspection (Page 32)
6. MAL- Chapter 32 NATEF Sheet Camshaft position Sensor( Page 32)
7. MAL- Chapter 33 NATEF Sheet Connecting Rod Specification/measuring (Page 30)
8. MAL- Chapter 33 NATEF Sheet Piston and bearing wear patterns (Page 31)
9. MAL- Chapter 33 NATEF Sheet Piston inspection and measurement (Page 31)
10. MAL- Chapter 33 NATEF Sheet Piston Pin replacement (Page 31)
11. MAL- Chapter 33 NATEF Sheet Piston Rings (Page 31)
12. MAL-Chapter 18.1 Animation Engine lubrication system (Page 37)
13. MAL – Chapter 69 NATEF Sheet Ignition system identification (Page 51)
14. MAL – Chapter 69 NATEF Sheet Spark plug Specification (Page 52)
15. MAL- Chapter 70 NATEF Sheet Ignition Scope analysis (Page 50)
16. MAL- Chapter 70 NATEF Sheet Position Sensor Waveform Test (Page 51)
17. MAL- Chapter 70 NATEF Sheet Ignition coil Test (Page 50)
18. MAL- Chapter 76 Animation Oxygen sensor designation (Page 38)
19. MAL- Chapter 69.2 Animation Signal generated from a permanent magnet sensor (Page 51)
20. MAL- Chapter 70.5 Animation Secondary Ignition Scope Pattern (Page 52)
21. MAL- Chapter 69.3 Animation Waste Spark DIS (Page 51)
22. MAL- Chapter 79.2 Animation Direct injected Fuel delivery (Page 45)
23. MAL Chapter 79 NATEF Sheet Gasoline direct-injection identification

- 24. MAL- Chapter 78.1 Activity Port fuel-injection system labeling (Page 43)
- 25. MAL Chapter 81 NATEF Sheet Injector Voltage waveform Test (Page 60)
- 26. MAL – Chapter 78.2 Activity label electronic throttle control system (Page 38)

## Review Questions / Answers

1. How does the Atkinson cycle differ from a conventional (Otto) four-stroke cycle? (Text page 26)  
**In the Atkinson cycle, the intake valve closes later than a conventional four-stroke cycle and combined with a high-compression ratio results in a greater expansion ratio and higher efficiency.**
  
2. What features are different between an engine used in a hybrid vehicle and the engine used in a conventional vehicle? (Text page 31)  
**Many inline four-cylinder engines used in hybrid electric vehicles use an offset crankshaft to reduce piston wall friction.**
  
3. What is an indexed spark plug? (Text page 38)  
**An indexed spark plug means that the spark plug is constructed so the open end of the electrodes face toward the intake valve when installed.**
  
4. How does the changing of the valve timing or opening affect the engine? (Text pages 31-32)  
**Changing the valve timing moves the torque curve either to high or low engine speeds to optimize engine performance and fuel economy.**
  
5. What is the difference between port fuel injection and gasoline direct-fuel injection? (Text page 45)  
**The injector is located about three inches from the intake valve in the intake manifold on a port fuel injection system and is located in the combustion chamber on a direct fuel engine system.**
  
6. What is the difference between a conventional oxygen sensor and a wide-band oxygen sensor? (Text pages 39-40)  
**A conventional oxygen sensor is able to detect an air-fuel mixture either richer or leaner than the**

**14.7:1. A wide-band oxygen sensor is able to detect air-fuel mixture as rich as 12:1 and as lean as 20:1 in many cases.**

**CHAPTER QUIZ QUESTIONS AND ANSWERS:**

1. Which is a characteristic of many hybrid electric vehicle (HEV) gasoline engines? (Text pages 24; 26; 31)
  - a. Smaller in displacement
  - b. Offset crankshaft
  - c. Variable valve timing and/or displacement
  - d. All of the above        X**
  
2. A hybrid electric vehicle (HEV) gasoline engine usually uses what viscosity of engine oil? (Text page 24)
  - a. SAE 0W-20    X**
  - b. SAE 5W-30
  - c. SAE 10W-30
  - d. SAE 20W-50
  
3. Brake horsepower is calculated using which of the following? (Text page 29)
  - a. Torque times RPM
  - b.  $2\pi$  times stroke
  - c. Torque times RPM divided by 5,252        X**
  - d. Stroke times bore times 3,300
  
4. Torque is expressed in units of \_\_\_\_\_. (Text pages 28-29)
  - a. Pound-feet    X**
  - b. Foot-pounds
  - c. Foot-pounds per minute



- d. Pound-feet per second
5. Horsepower can also be expressed in units of \_\_\_\_\_. (Text page 29))
- a. Pound-feet
  - b. Foot-pounds
  - c. Foot-pounds per minute X**
  - d. Pound-feet per second
6. Hybrid electric vehicle gasoline engines often use what systems to achieve maximum fuel economy? (Text pages 31-36; 39-43)
- a. Returnless fuel delivery system
  - b. Wide-band oxygen sensors
  - c. Variable valve timing
  - d. All of the above X**
7. The Atkinson cycle engine design \_\_\_\_\_. (Text page 26)
- a. Requires special fuel and oil designed for this type of engine
  - b. Operates differently than the normal four stroke cycle gasoline engine
  - c. Uses the same four stroke cycle but delays the closing of the intake valve X**
  - d. Both a and b are correct
8. A wide-band oxygen sensor is used to \_\_\_\_\_. (Text page 39)
- a. Help the engine achieve a super ultra-low emission vehicle (SULEV) rating
  - b. Help improve fuel economy by allowing the engine to operate at a lean air–fuel ratio
  - c. Help the engine meet achieve ultra-low emission vehicle (ULEV) rating
  - d. All of the above X**

9. The use of an offset crankshaft is used to \_\_\_\_\_. (Text page 31)
- a. Improve power output of the engine
  - b. To improve the fuel economy by reducing internal engine friction X**
  - c. To reduce engine noise
  - d. All of the above
10. One key way to improve fuel economy is to reduce pumping losses. What methods is used in many hybrid's to reduce pumping losses? (Text pages 26; 31; 38)
- a. Use the Atkinson cycle
  - b. Use electronic throttle control (ETC)
  - c. Use variable valve timing
  - d. All of the above X**

## ASE / NATEF Correlation Charts

1.

## Suggestions for related instruction (web links / books / movies / etc.)

1. <http://www.superflow.com/Dynamometers/Engine/index.html>
2. [http://www.enginebuildermag.com/Article/1948/piston\\_design\\_an\\_evolutionary\\_tale.aspx](http://www.enginebuildermag.com/Article/1948/piston_design_an_evolutionary_tale.aspx)
3. <http://auto.howstuffworks.com/camshaft2.htm>
4. <http://www.autobytel.com/car-ownership/variable-valve-timing-vvt-104258/>
5. [http://www.lexus.com.sa/technology\\_explorer/active\\_control\\_engine\\_mount.asp?model=4\\_RX350](http://www.lexus.com.sa/technology_explorer/active_control_engine_mount.asp?model=4_RX350)
6. <http://sciencelinks.jp/j-east/article/200324/000020032403A0737780.php>
7. <http://delphi.com/manufacturers/auto/powertrain/gas/ignsys/ionized/>
8. <http://auto.howstuffworks.com/car-driving-safety/safety-regulatory-devices/electronic-throttle-control-systems.htm>
9. <http://auto.howstuffworks.com/direct-injection-engine.htm>

10. <http://auto.howstuffworks.com/symptoms-ignition-coil-failure.htm>
11. <http://auto.howstuffworks.com/ignition-system5.htm>
12. <http://auto.howstuffworks.com/fuel-injection3.htm>
13. <http://auto.howstuffworks.com/direct-injection-engine4.htm>
14. <http://auto.howstuffworks.com/direct-injection-engine.htm>

# Chapter 4

## Gasoline

### Chapter Summary

1. Gasoline is a complex blend of hydrocarbons. Gasoline is blended for seasonal use to achieve the correct volatility for easy starting and maximum fuel economy under all driving conditions.
2. Winter-blend fuel used in a vehicle during warm weather can cause a rough idle and stalling because of its higher Reid vapor pressure (RVP).
3. Abnormal combustion (also called detonation or spark knock) increases both the temperature and the pressure inside the combustion chamber.
4. Most regular-grade gasoline today, using the  $(R + M) \div 2$  rating method, is 87 octane; midgrade (plus) is 89, and premium grade is 91 or higher.
5. Oxygenated fuels contain oxygen to lower CO exhaust emissions.
6. Gasoline should always be purchased from a busy station, and the tank should not be overfilled.

### Key Terms

• Air–fuel ratio 51 • Antiknock index (AKI) 52 • ASTM 49 • British thermal unit (BTU) 50 • Catalytic cracking 48 • Cracking 48 • Detonation 51 • Distillation 47 • Distillation curve 49 • Driveability index (DI) 49 • E10 54 • Ethanol 54 • Fungible 48 • Gasoline 47 • Hydrocracking 48 • Octane rating 51 • Oxygenated fuels 54 • Petroleum 47 • Ping 51 • Reformulated gasoline (RFG) 55 • RVP 49 • Spark knock 51 • Stoichiometric 51 • Tetraethyl lead (TEL) 52 • Vapor lock 49 • Volatility 49 • WWFC 57

### Objectives

1. Explain how gasoline is refined from crude oil. (Page 48)
2. Describe how the proper grade of gasoline affects engine performance. (Page 51-52)
3. List gasoline purchase hints. (Page 58)
4. Discuss how volatility affects driveability.(Page 49)
5. Explain how oxygenated fuels can reduce CO exhaust emissions (Page 54)

6. Discuss safety precautions when working with gasoline.(Page 58)

## Lecture Resources:

### Search the Internet

1. Have the students complete an MSDS review of hydrocarbons to determine whether they understand the hazards of hydrocarbons. (Page 47)
2. Have the students research the environmental ramifications that could occur if we continue to use crude oil as our fuel base. Will there be permanent damage to the environment? How long does it take for a crude oil well to refill itself naturally? Have the students write a summary and analysis of their findings. Ask them to share their findings with the class. (Page 48)
3. Have the students use the Internet to research RVP standards. Who issues RVP standards? Do the standards vary from state to state? Ask the students to find out about standards for your state. Have them summarize their findings in a report to share with the class. (Page 49)
4. Have the students research other units used to measure energy besides BTUs, including joules, watts and calories. Ask them to identify the basis of these measurement units and the context in which they are used. Have them create a chart that compares and contrast the uses of energy units. Ask students to present their charts to the class. (Page 50)
5. Have the students use the Internet to research why the U.S. Federal Test Procedure uses indolene for testing. Have them write a summary of their findings. Ask them to present their summaries to the class. (Page 53)
6. Have the students use the Internet to research the use of E85 fuel and identify vehicles that can accept E85. Ask them to find out why many owners of flexible fuel vehicles are unaware that their vehicles could utilize E85. Have them share their findings about E85 with the class. (Page 54)

**ASSESS** - Have the students use a five-gas analyzer on a vehicle. Ask them to record readings and interpret their findings. Grade them on their understanding of the by-products of the combustion process and their awareness of what is required to reduce harmful emissions. (Page 51)

**CROSS Curricular Activity: Science**- Have the students' research relative volatility. Have them summarize what relative volatility is and the effect of temperature and pressure on relative volatility. Ask them to share their findings with the class. (Page 54)

**CROSS Curricular Activity: Science-** Have the students' research formaldehyde. Ask them to identify the toxicity of formaldehyde and its contribution to smog. Ask them to report their findings to the class. (Page 56)

**ASSESS-** Have the students use the graduated cylinder method to determine the alcohol content of fuel in a vehicle in the shop. Grade them on safety, thoroughness, and accuracy. (Page 56)

**CROSS Curricular Activity: Science-** Have the students research formaldehyde. Ask them to identify the toxicity of formaldehyde and its contribution to smog. Ask them to report their findings to the class. (Page 57)

**ASSESS-** Have the students write a summary of general gasoline recommendations. Grade them on their understanding of operation cost, as well as proper operation of the engine based on the proper octane rating and atmospheric conditions. (Page 58)

**ASSESS-** Have the student use a fuel composition tester to test the alcohol content of fuel in a vehicle. Grade them on safety, verifying the proper operation of the tester, and accurate reading and calculations. (Page 59)

#### **Additional Topics:**

1. <http://www.howstuffworks.com/gasoline.htm> (Page 66)
2. <http://auto.howstuffworks.com/fuel-efficiency/fuel-consumption/summer-fuel.htm> (Page 49)
3. <http://auto.howstuffworks.com/fuel-efficiency/fuel-consumption/question90.htm> (Page 50)

#### **Discuss**

1. Have the students talk about the chemical composition of gasoline. How many carbon atoms do the hydrocarbons in gasoline have? (Page 47)
2. Have the students talk about the danger of hydrocarbons. Is a hydrocarbon harmful as a liquid? Is it harmful as a gas? What safety precautions should be taken when handling hydrocarbons? (Page 47)
3. **TIP-** having different grades of gasoline, different blends and varying freshness on hand as you discuss gasoline will offer the students a variety of fuels to observe and test. (Page 47)
4. Have the students talk about the distillation process. In addition to fuel, what other products are produced through the distillation process. (Page 48)

5. Have the students discuss the cracking process. What is the difference between thermal cracking, catalytic cracking, and Hydrocracking? (Page 48)
6. Have the students discuss cold start problems that are related to fuel issues. Why is it important for fuel to have a specific RVP reading? (Page 49)
7. Have the students talk about grades of gasoline. Is it always better to use premium gas? Point out the problems of hard start and rough idle using premium-grade gasoline during cold weather conditions. (Page 50)
8. Have the students talk about the gasoline combustion process. Will a contaminated atmosphere have an effect on the combustion process? (Page 50)
9. Have the students discuss air-fuel ratios. What makes an air-fuel mixture too rich or too lean? (Page 50)
10. Have the students talk about how air-fuel ratios are stated. Why is the ratio usually measured by weight and not volume? (Page 51)
11. Have the students refer to figure 4-5 and discuss what happens to NO<sub>x</sub>, CO, and HC in a three-way catalytic converter. Why does a stoichiometric ratio work best to control these mixtures? (Page 51)
12. Have the students talk about injector flow rate. What is the relation of injector flow to horsepower? (Page 53)
13. Have the students talk about octane rating. How is isooctane used in octane rating? What are the methods used to rate gasoline for antiknock properties? (Page 53)
14. Have the students discuss high-altitude octane requirements. What happens to air when atmospheric pressure drops? How does lowered atmospheric pressure affect octane ratings? (Page 53)
15. **Hands-ON**- have the students locate a knock sensor on a vehicle. Ask them to review the manufacturer's information about the sensor. Have the students use a scan tool to compare it to the live data from the sensor. Is the knock sensor accurate? (Page 54)
16. Have the students discuss gasoline additives. What problem can be caused by additives? (Page 54)
17. Have students talk about oxygenated fuel additives. Under what conditions can additives be used to improve driveability? (Page 55)

18. **Environment-** Additives have been used for many years to improve driveability. Ask the students to discuss what is happening to the environment as a result of using additives. (Page 55)
19. Have the students talk about adding ethanol to base gasoline. Why are there different methods for adding additives to create an E10 fuel mixture? (Page 55)
20. Have the students talk about reformulated gasoline. Will reformulated gas work well in cold weather conditions? (Page 56)
21. Have the students discuss the changes made to reformulated gasoline. What has been the result in areas where reformulated gas is being used? (Page 56)
22. Remind students of the importance of testing fuel for alcohol and water. How can not testing the fuel for alcohol and water affect the repair of driveability problems associated with a fuel mixture? (Page 56)
23. Have the students discuss keeping the fuel level above one-quarter tank. Why should the fuel level be kept above that level? (Page 56)
24. Have students discuss keeping the fuel level above one-quarter tank. Why should the fuel level be kept above that level? (Page 57)
25. Have students talk about reformulated gasoline. Will reformulated gas work well in cold weather conditions? (Page 57)
26. Have the student talk about the effects of using a fuel with a higher octane rating than is necessary. When is a mid-grade fuel a good compromise of cost and fuel economy? (Page 58)
27. **Safety-** people continue to use cell phone when they enter and exit vehicles that are being filled with gas. Remember the students of the danger of an accidental spark from static electricity. (Page 58)
28. **TIP-** when a rich mixture is detected and the fuel gauge reads full, remind the students to check the Charcoal canister outlet to the engine. Verify to see whether liquid gas is being sucked into the engine. A temporary blockage of the line and repeated checking of O2 sensor readings could verify this condition. (Page 58)
29. Have the students talk about using a fuel composition tester to test for alcohol content in gasoline. What is the first step to using a tester? (Page 59)



30. **SAFETY**- Discuss with the students the importance of having a fire extinguisher available when working with fuel and of wearing PPE including safety glasses, a respirator, and gloves. (Page 59)

## **Demonstrate**

1. Locate a video that demonstrates the distillation process. Have the students watch it and then discuss the process. The national geographic Channel or Discovery Channel videos are possible video sources. (Page 48)
2. Show the students how to test gasoline, emphasizing the RVP reading as a classification for usage. (Page 49)
3. Show the students how the fuel injector sprays fuel into the combustion chamber by creating an external fuel system in which the students can view an injector spraying fuel into a visible container. For safety reasons you can perform this demonstration with water instead of fuel, keeping in mind that the injectors and pump sustain damage from the water long-term use. (Page 50)
4. Have the students listen to a vehicle making a knocking sound due to detonation. Ask them to describe what this sounds like to them. (Page 52)
5. Place some gas and water in a clear container for viewing. Have the students talk about phase separation. Discuss what happens when an engine combust a little water. What will happen to cylinder temperature if this happens? (Page 54)
6. Show the students how to check for alcohol content in gas. Remind them of the safety precautions to take when testing gasoline. (Page 56)
7. Demonstrate a sniff test on stale gasoline. Talk about what gasoline stabilizers is, when to use it, and where to find it. (Page 56)

## **Student Activities**

1. MAL Chapter 66.2 Animation piston Component ID (Page 52)
2. MAL Chapter 66 NATEF Sheet Alcohol content in gasoline (Page 56)
3. MAL Chapter 66 Power Point (Page 47)

## **Review Questions / Answers**

1. What is the difference between summer-blend and winter-blend gasoline? (Text page 49)

**The major difference is the volatility of the gasoline. Winter gasoline needs to have a higher RVP pressure to ignite at low temperatures, whereas summer gasoline required a lower RVP to prevent vapors from forming in the fuel system.**

2. What is Reid vapor pressure? (Text page 49)

**The pressure of the gasoline vapor in a closed container measured at 100°F.**

3. What is vapor lock? (Text page 49)

**Vapor lock is a condition where vapors instead of liquid fuel is in the fuel system and can result in poor engine performance or even a no-start condition.**

4. What does the  $(R + M) \div 2$  gasoline pump octane rating indicate? (Text page 52)

**The pump octane rating is the average of the fuel measured using the Motor and Research method.**

5. What are five octane improvers that may be used during the refining process? (Text pages 53-54)

**Octane improvers added in the refining process include: xylene, toluene, ethanol, methanol, tertiary butyl alcohol (TBA), as well as propane and butane.**

6. What is stoichiometric? (Text page 51)

**Stoichiometric is a ratio where all of the fuel is burned with all of the air. The Stoichiometric ratio varies according to the fuel used.**

#### **CHAPTER QUIZ QUESTIONS AND ANSWERS:**

1. Winter-blend gasoline \_\_\_\_\_. (Text page 49)

- a. Vaporizes more easily than summer-blend gasoline
- b. Has a higher RVP

c. Can cause engine driveability problems if used during warm weather

**d. All of the above X**

2. Vapor lock can occur \_\_\_\_\_. (Text page 49)

a. As a result of excessive heat near fuel lines

b. If a fuel line is restricted

**c. During both a and b X**

d. During neither a nor b

3. Technician A says that spark knock, ping, and detonation are different names for abnormal combustion.

Technician B says that any abnormal combustion raises the temperature and pressure inside the combustion chamber and can cause severe engine damage. Which technician is correct? (Text page 51)

a. Technician A only

b. Technician B only

**c. Both Technicians A and B X**

d. Neither Technician A nor B

4. Technician A says that the research octane number is higher than the motor octane number. Technician B says that the octane rating posted on fuel pumps is an average of the two ratings. Which technician is correct? (Text page 52)

a. Technician A only

b. Technician B only

**c. Both Technicians A and B X**

d. Neither Technician A nor B

5. Technician A says that in going to high altitudes, engines produce lower power. Technician B says that most engine control systems can compensate the air-fuel mixture for changes in altitude. Which technician is correct? (Text page 53)

a. Technician A only

b. Technician B only

**c. Both Technicians A and B X**

- d. Neither Technician A nor B
6. Which method of blending ethanol with gasoline is the most accurate? (Text page 55)
- a. **In-line X**
  - b. Sequential
  - c. Splash
  - d. All of the above are equally accurate methods
7. What can be used to measure the alcohol content in gasoline? (Text pages 56; 59)
- a. Graduated cylinder
  - b. Electronic tester
  - c. Scan tool
  - d. **Either a or b X**
8. To avoid problems with the variation of gasoline, all government testing uses \_\_\_\_\_ as a fuel during testing procedures. (Text page 52)
- a. MTBE (methyl tertiary butyl ether)
  - b. **Indolene X**
  - c. Xylene
  - d. TBA (tertiary butyl alcohol)
9. Avoid topping off the fuel tank because \_\_\_\_\_. (Text page 57)
- a. **It can saturate the charcoal canister X**
  - b. The extra fuel simply spills onto the ground
  - c. The extra fuel increases vehicle weight and reduces performance
  - d. The extra fuel goes into the expansion area of the tank and is not used by the engine
10. Using ethanol-enhanced or reformulated gasoline can result in reduced fuel economy. (Text page 55)

a. True X

b. False

## ASE / NATEF Correlation Charts

1.

### Suggestions for related instruction (web links / books / movies / etc.)

1. <http://www.howstuffworks.com/environmental/energy/oil-refining4.htm>
2. <http://blog.gasbuddy.com/posts/A-crash-course-on-seasonal-gasoline/1715-401024-239.aspx>
3. <http://video.search.yahoo.com/video/play?p=engine%20detonation&tr=21&vid=1531902035448&l=12&turl=http%3A%2F%2Fts1.mm.bing.net%2Fvideos%2Fthumbnail.aspx%3Fq%3D1531902035448%26id%3D9a5ccd83e1309dfb342afdc243aa57a9%26bid%3DKWOkqW1N65gyPw%26bn%3DThumb%26url%3Dhttp%253a%252f%252fwww.youtube.com%252fwatch%253fv%253duVnO9o44Mfo&rurl=http%3A%2F%2Fwww.youtube.com%2Fwatch%3Fv%3DuVnO9o44Mfo&sigr=11akr5oqo&newfp=1&tit=Nissan+Skyline+R32+Engine+Detonation+1>
4. [http://www.ehow.com/facts\\_7715433\\_injector-cc-horsepower-ratio.html](http://www.ehow.com/facts_7715433_injector-cc-horsepower-ratio.html)

# Chapter 5

## Alternative Fuels

### Chapter Summary

1. Flexible fuel vehicles (FFVs) are design to operate on gasoline or gasoline-ethanol blends up to 85% ethanol (E85).
2. Ethanol can be made from grain, such as corn, or from cellulosic biomass, such as switchgrass.
3. E85 has fewer BTUs of energy per gallon compared with gasoline and will therefore provide lower fuel economy.
4. Older flexible fuel vehicles used a fuel compensation sensor but newer models use the oxygen sensor to calculate the percentage of ethanol in the fuel being burned.
5. Methanol is also called methyl alcohol or wood alcohol and, while it can be made from wood, it is mostly made from natural gas.
6. Propane is the most widely used alternative fuel. Propane is also called liquefied petroleum gas (LPG).
7. Compressed natural gas (CNG) is available for refilling in several pressures, including 2,400 PSI, 3,000 PSI, and 3,600 PSI.
8. P-series fuel is recognized by the United States Department of Energy as being an alternative fuel. P-series fuel is a non-petroleum-based fuel suitable for use in a flexible fuel vehicle. However, P-series fuel is not commercially available.
9. Synthetic fuels are usually made using the Fischer-tropsch method to convert coal or natural gas into gasoline and diesel fuel.
10. Safety procedures when working around alternative fuel include wearing the necessary personal protective equipment (PPE), including safety glasses and protective gloves.

### Key Terms

AFV 63 • Anhydrous ethanol 62 • Biomass 67 • Cellulose ethanol 62 • Cellulosic biomass 62 • Coal to liquid (CTL) 71 • Compressed natural gas (CNG) 68 • E85 62 • Ethanol 61 • Ethyl alcohol 61 • FFV 63 • Fischer-Tropsch 71 • Flex Fuels 63 • FTD 71 • Fuel compensation sensor 63 • Gas to liquid (GTL) 71 • Grain alcohol 61 • Liquid

petroleum gas (LPG) 67 • LP-gas 67 • M85 67 • Methanol 67 • Methanol to gasoline (MTG) 71 • NGV 68 • Propane 67 • Switchgrass 62 • Syncrude 71 • Syn-gas 67 • Synthetic fuel 71 • Underground coal gasification (UCG) 71 • V-FFV 64  
• Variable fuel sensor 63

## Objectives

1. Describe how alternative fuels affect engine performance. (Pages 61-71)
2. List alternatives to gasoline (Pages 67-71)
3. Discuss how alternative fuels affect driveability (Pages 61-71)
4. Explain how alternative fuels can reduce CO exhaust emissions (Pages 61-71)
5. Discuss safety precautions when working with alternative fuels (Page 72)

## Lecture Resources:

### Search the Internet

1. Have the students use the Internet to find manufacturers' specifications for variable fuel sensors, including GM, Ford, Mazda, and Honda. Have them compare the specifications from the different manufacturers. Ask students to present their findings to the class. (Page 62)
2. Have the students use the Internet to research the cost of flex-fuel vehicles that are currently available for purchase. How does their cost compare to that of regular vehicles? Ask students to present their findings to the class. (Page 63)
3. Have the students use the Internet to research issues related to ethanol, including availability, blends and federal incentives for ethanol retailers, and so forth. Have them go to [e85fuel.com](http://e85fuel.com) and locate the nearest E85 station in your area. Ask students to summarize their findings and share them with the class. (Page 66)
4. Have the students identify current uses of CNG vehicles. What types of vehicles are using CNG? Ask students to present their findings to the class. (Page 68)
5. Have the students search the Internet for fleets that use liquefied natural gas in your area. Ask students to summarize their findings and share them with the class. (Page 69)

6. Have the students use the Internet to find additional information on P-series fuels. What are the pros and cons of this type of fuel? Ask the students to write a summary of their findings to share with the class. (Page 70)

**CROSS Curricular Activity: Science** Have the students identify the chemical structure and formula of polysaccharides. What types of fuel are derived from polysaccharides? Have students present their findings to the class. (Page 61)

**ASSESS** – Have the students' select one vehicle from the flexible fuel vehicle listed on page 65. Have students identify special features on the E85 vehicle and explain why the vehicle is identified as a flex-fuel. Grade them on their understanding of flex-fuel vehicles. (Page 65)

**CROSS Curricular Activity: Science** Have the students research the properties of propane and LPG. How does propane combustion compare to gasoline combustion? Ask students to share their findings with the class. (Page 67)

**CROSS Curricular Activity: Science** Have the students research the properties of GTL fuel. How complete is GTL fuel combustion? What are emissions like with the use of GTL fuel? Ask students to present their findings to the class. (Page 71)

**ASSESS** – Have the students write a report on alternative fuels. Grade them on thoroughness and their understanding of how alternative fuels are produced and used, and what their benefits and drawbacks are. (Page 72)

### **Additional Topics:**

1. <http://joannestafferton.suite101.com/polysaccharides-a28515> (Page 61)
2. [http://www.fuel-testers.com/ethanol\\_fuel\\_disadvantages.html](http://www.fuel-testers.com/ethanol_fuel_disadvantages.html) (Page 63)
3. <http://www.biology-online.org/dictionary/Denatured> (Page 61)
4. <http://www.fueleconomy.gov/feg/flextech.shtml> (Page 65)
5. <http://methanol.org/> (Page 67)
6. <http://www.iags.org/pseries.htm> (Page 70)
7. <http://www.consumerenergycenter.org/transportation/afvs/gtl.html> (Page 71)

### **Discuss**

1. Have the students discuss ethanol and how it is produced. Since ethanol produced for fuel is the same as that in alcoholic drinks, can drink manufacturers produce fuel for vehicles? (Page 61)



2. **SAFETY** – review the meaning of denatured. Remind the students that when fuel becomes denatured, it is unfit for human consumption. (Page 61)
3. Have the students talk about cellulose biomass? How are the greenhouse effects of the combustion of biomass offset? (Page 62)
4. **Environment-** There has been a big push to use alternative fuels to reduce pollution. We tend to forget that pollution is sometimes created when alternative fuels are developed. The goal is to create less pollution in the process of developing alternate fuels. (Page 62)
5. Have the students talk about E85 and its effects on fuel economy. Is it worth using E85 since you have to purchase more E85 than regular gas for the same mileage? What is the price difference between regular gas and E85? (Page 63)
6. Have the students discuss E85 fuel system requirements. What additional hardware is on E85 vehicles? (Page 63)
7. Have the students talk about enhanced fuel system components and materials used for flex-fuel vehicles. Can ethanol damage common fuel pumps? What will happen to O-rings that are not alcohol-resistant? (Page 64)
8. Have the students talk about vehicles listed on page 65. Has there been an increase in E85 vehicles? Has there been an increase in different styles of E85 vehicles? Why or why not? (Page 65)
9. **Hands-ON-** Have the students locate VECI on flex-fuel vehicles you have in your shop. Have students share locations and information found. (Page 65)
10. Have the students discuss fuel compensation. Have them compare the use of a fuel compensation sensor and an oxygen sensor for a flex-fuel system. Why should a technician avoid resetting fuel compensation? (page 66)
11. Have the students talk about storage of oxygenated fuel. How does that shelf life of oxygenated fuel compare to that of other fuels? (Page 66)
12. **Hands-ON-** Have the students diagnose a vehicle with an O2 code present. Help them use a diagnostic scanner multimeter and five- gas analyzer, as needed, for their diagnoses. (Page 66)
13. Have the students talk about methanol and its production,. What is the biggest source of methanol in the United States? What is M85? (Page 67)
14. **SAFETY-** Review with students the PPE that should be used when handling methanol. Talk about ventilation procedures when working with methanol

vehicles, including where exhaust fans should be placed, opening bay doors, monitoring running vehicles in the shop and so forth. (Page 67)

15. Have the students talk about propane. How does propane's use compare to that of other fuels? Why is propane less economical to use than other fuels? (Page 67)
16. Have the students talk about compressed natural gas. Why is natural gas odorized during production? (Page 68)
17. Have the students discuss differences between using gasoline and natural gas in vehicles. What design differences are required for a CNG engine? (Page 68)
18. Have the students discuss CNG fuel systems. What is the importance of having lock-off valves in CNG vehicles? (Page 69)
19. Discuss refueling of CNG vehicles. Why is it important to fill a CNG vehicle's tank slowly? (Page 93)
20. Have the students talk about liquefied natural gas. What are the practicalities of using LNG in vehicles? (Page 70)
21. Have the students talk about tri-fuel vehicles. Which fuels are tri-fuel vehicles capable of using? (Page 70)
22. Have the students use chart 5-2 to review the advantages and disadvantages of alternative fuels. Which have fossil fuel sources? (Page 70)
23. Have the students' discuss the Fischer-Tropsch method. What is the biggest drawback to Fischer-Tropsch fuels? (Page 71)
24. Have the students discuss the future of synthetic fuels. How is the rising cost of crude oil affecting the cost effectiveness of alternative methods of producing fuels? (Page 96)
25. **SAFETY**- when working on fuel systems, equipment that can create a spark/flame should be removed from the area. Have the students review their shop area and address which items should be removed for working on fuel systems. (Page 72)

## **Demonstrate**

1. Show the students the location of the variable fuel sensor. Review its function with the students. (Page 63)

2. Use a flex-fuel vehicle to show the students the identifiers that place it in the E85 class. Talk about emissions produced by ethanol fueled vehicles. (Page 64)

## Student Activities

1. MAL chapter 67 Power Point (Page 61)
2. MAL Chapter 67 NATEF Sheet Alternative fuels (Page 63)

## Review Questions / Answers

1. . Ethanol is also known by what other terms? (Text page 61)

**Ethyl alcohol and grain alcohol are other terms that mean the same as ethanol.**

2. The majority of ethanol in the United States is made from what farm products? (Text page 61)

**Ethanol is most commonly made from corn, grain, sorghum, wheat, barley, and potatoes.**

3. How is a flexible fuel vehicle identified? (Text page 64)

**A flexible fuel vehicle (FFV) can be identified by:**

- **Emblems on the side, front, and/or rear of the vehicle**
- **VECI sticker information**
- **VIN designation**

4. Methanol is also known by what other terms? (Text page 67)

**Methanol is also called methyl alcohol, wood alcohol, or methyl hydrate.**

5. What other gases are often mixed with propane? (Text page 67)

**Propane is also called liquefied petroleum gas (LPG) because it is often mixed with butane, propylene, butylenes, as well as mercaptan to give it a smell.**

6. Why is it desirable to fill a compressed natural gas (CNG) vehicle with the highest pressure available? (Text page 69)

**The higher the pressure is, the more gas can be installed in the pressurized tank and the larger the range of the vehicle.**

7. P-series fuel is made of what products? (Text page 70)

**P-series fuel is made from:**

- Ethanol
- MTHF
- Natural gas liquids
- Butane

8. The Fischer-Tropsch method can be used to change what into gasoline? (Text page 71)

**The Fischer-Tropsch method can use coal, natural gas, and other fossil fuel products to produce gasoline and diesel fuels.**

#### **CHAPTER QUIZ QUESTIONS AND ANSWERS:**

1. Ethanol can be produced from what products? (Text pages 61-62)

- a. Switchgrass
- b. Corn
- c. Sugarcane
- d. Any of the above X**

2. E85 means that the fuel is made from \_\_\_\_\_. (Text page 62)

- a. 85% gasoline, 15% ethanol
- b. 85% ethanol, 15% gasoline X**
- c. Ethanol that has 15% water
- d. Pure ethyl alcohol

3. A flex-fuel vehicle can be identified by \_\_\_\_\_. (Text page 64)

- a. Emblems on the side, front, and/or rear of the vehicle
- b. VECI
- c. VIN
- d. Any of the above X**

4. Methanol is also called \_\_\_\_\_. (Text page 67)

- a. Methyl alcohol
- b. Wood alcohol
- c. Methyl hydrate
- d. All of the above X**

5. Which alcohol is dangerous (toxic)? (Text page 67)

- a. Methanol X**
- b. Ethanol
- c. Both ethanol and methanol
- d. Neither ethanol nor methanol

6. Which is the most widely used alternative fuel? (Text page 67)

- a. E85
- b. Propane X**
- c. CNG
- d. M85

7. Liquefied petroleum gas (LPG) is also called \_\_\_\_\_. (Text page 67)

- a. E85
- b. M85
- c. Propane X**

- d. P-series fuel
8. How much compressed natural gas (CNG) does it require to achieve the energy of one gallon of gasoline? (Text page 69)
- a. 130 cubic feet
  - b. 122 cubic feet X**
  - c. 105 cubic feet
  - d. 91 cubic feet
9. When refueling a CNG vehicle, why is it recommended that the tank be filled to a high pressure? (Text page 69)
- a. The range of the vehicle is increased X**
  - b. The cost of the fuel is lower
  - c. Less of the fuel is lost to evaporation
  - d. Both a and c
10. Producing liquid fuel from coal or natural gas usually uses which process? (Text page 71)
- a. Syncrude
  - b. P-series
  - c. Fischer-Tropsch X**
  - d. Methanol to gasoline (MTG)

## ASE / NATEF Correlation Charts

1.

### Suggestions for related instruction (web links / books / movies / etc.)

1. <http://www.freepatentsonline.com/y2007/0218345.html>

2. <http://www.energy-consumers-edge.com/problems-with-ethanol-fuel.html>
3. <http://www.technologyreview.com/energy/22198/>
4. <http://www.altfuels.org/backgrnd/altftype/m85.html>
5. <http://alternativefuels.about.com/od/pseries/a/Pseries101.htm>
6. <http://www.youtube.com/watch?v=BHGynZJYf1Y>

# Chapter 6

## Diesel and Biodiesel Fuels

### Chapter Summary

1. Diesel fuel produces 12% more heat energy than the same amount of gasoline.
2. Diesel fuel requirements include cleanliness, low-temperature fluidity, and proper cetane rating.
3. Emission control devices used on 2007 and newer engines require the use of ultra-low-sulfur diesel (ULSD) that has less than 15 parts per million (PPM) of sulfur
4. The density of diesel fuel is measured in a unit called API gravity.
5. The cetane rating of diesel fuel is a measure of the ease with which the fuel can be ignited.
6. Biodiesel is the blend of vegetable-based liquid with regular diesel fuel. Most diesel engine manufactures allow the use of a 5% blend, called B5 without any changes to the fuel system or engine.
7. E-diesel is a blend of ethanol with diesel up to 15% ethanol by volume.

### Key Terms

API gravity 75 • ASTM 74 • B20 77 • Biodiesel 76 • Cetane number 74 • Cloud point 74 • Diesohol 78 • E-diesel 78 • Petrodiesel 77 • PPO 77 • SVO 77 • UCO 77 • ULSD 76 • WVO 77

### Objectives

1. Explain diesel fuel specifications. (Page 74)
2. List the advantages and disadvantages of biodiesel. (Page 75)
3. Discuss API gravity. (Page 75)
4. Explain E-diesel specifications. (Page 76)

### Lecture Resources:

Search the Internet



1. Have the students use the Internet to research the differences and similarities between diesel and gasoline. Ask students to present their findings to the class.(Page 74)
2. Have the students use the Internet to research the methods for testing sulfur content of fuel. What are the standards for sulfur content? Why is measuring the sulfur in diesel important? Ask students to report their findings to the class. (Page 76)
3. Have the students use the Internet to identify retailers in your state that are selling biodiesel. Ask students to share their findings with the class. (Page 77)

**ASSESS** – Have the students sample diesel fuel and take an API gravity reading. Have them use Chart 6-1 to find the weight density and pounds per gallon of the fuel that they are sampling. (Page 75)

**ASSESS** – Have the students explain what a cetane rating means. Grade them on their understanding of cetane number and what it indicates about a fuel. (Page 77)

#### **Additional Topics:**

1. <http://alternativefuels.about.com/od/researchdevelopment/a/cetane.htm>
2. <http://www.chemcool.com/elements/sulfur.html>
3. [http://www.csgnetwork.com/specific\\_gravity\\_viscosity\\_liquids.html](http://www.csgnetwork.com/specific_gravity_viscosity_liquids.html)
4. <http://www.biodiesel.org/>

#### **Discuss**

1. Have the students talk about the features and requirements of diesel fuel. Review with students what ambient temperature is. What is meant by diesel fuel's "pour point"? (Page 74)
2. Have the students discuss cloud point. How does cloud point affect filters? How do diesel fuel suppliers accommodate pour point and cloud points? (Page 74)
3. Have the students talk about the cetane number for diesel fuel. Review with the students why the octane rating for diesel is lower than the octane rating for gasoline. Does combustion pressure affect diesel fuel's cetane number? (Page 74)

4. Have the students talk about grades of diesel fuel. In which applications is Grade #1 used? Why? In which applications is Grade # 2 Used? Why/ (Page 75)
5. **SAFETY-** Review with the students the safety precautions that should be taken when working with, and testing, diesel fuel. (Page 75)
6. Have the students talk about why sulfur dioxide is harmful to the environment. What is the difference in appearance of ULSD? (Page 76)
7. Have the students talk about biodiesel blends. Can B20 be used in unmodified diesel engines? Since biodiesel cost more than regular diesel, what are its benefits? (Page 77)
8. Have the students talk about biodiesel in relation to vegetable oil. What is the difference between biodiesel powered vehicles and vegetable-oil-powered vehicles? (Page 77)
9. Have the students discuss E-diesel fuel. What is a typical blend level for E-diesel? (Page 77)

## **Demonstrate**

1. Obtain regular diesel and off-road diesel to show to the students. Have them visually note the difference in the two fuels. (Page 74)
2. Use a hydrometer to show the students how to test API gravity of diesel. (Page 74)
3. Show the students the location of the fuel heater and fuel filter on a diesel vehicle. (Page 76)

## **Student Activities**

1. MAL chapter 68 Power Point (Page 74)
2. MAL Chapter 68 NATEF Sheet Diesel fuels (Page 74)
3. MAL Chapter 68 NATEF Sheet Biodiesel fuels (Page 76)
4. MAL Chapter 69 Review Questions

## **Review Questions / Answers**

1. What is meant by the cloud point? (Text page 74)

**The cloud point is the low-temperature point when the waxes in the diesel fuel tend to form crystals that can clog the fuel filter.**

2. What is ultra low sulfur diesel? (Text page 76)

**Ultra low sulfur diesel has 15 parts per million of sulfur.**

3. Bio-diesel blends are identified by what designation? (Text page 77)

**Bio-diesel is designated with the capital letter "B" followed by the percentage of bio-diesel added to the petroleum-based diesel fuel. B20 indicates that it contains 20% biodiesel. B5 means that it contains 5% biodiesel.**

#### **CHAPTER QUIZ QUESTIONS AND ANSWERS:**

1. What color is diesel fuel dyed if it is for off-road use only? (Text page 74)

- a. **Red X**
- b. Green
- c. Blue
- d. Yellow

2. What clogs fuel filters when the temperature is low on a vehicle that uses diesel fuel? (Text page 74)

- a. Alcohol
- b. Sulfur
- c. **Wax X**
- d. Cetane

3. The specific gravity of diesel fuel is measured in what units? (Text page 75)

- a. Hydrometer units
  - b. API gravity X**
  - c. Grade number
  - d. Cetane number
  
- 4. What rating of diesel fuel indicates how well a diesel engine will start? (Text page 74)
  - a. Specific gravity rating
  - b. Sulfur content
  - c. Cloud point
  - d. Cetane rating X**
  
- 5. Ultra-low-sulfur diesel fuel has how much sulfur content? (Text page 76)
  - a. 15 PPM X**
  - b. 50 PPM
  - c. 500 PPM
  - d. 1,500 PPM
  
- 6. E-diesel is diesel fuel with what additive? (Text page 78)
  - a. Methanol
  - b. Sulfur
  - c. Ethanol X**
  - d. Vegetable oil
  
- 7. Biodiesel is regular diesel fuel with vegetable oil added. (Text page 76)
  - a. True
  - b. False X**
  
- 8. B20 biodiesel has how much regular diesel fuel? (Text page 77)
  - a. 20%

- b. 40%
- c. 80% X**
- d. 100%

9. Most diesel fuel is what grade? (Text page 75)

- a. Grade #1
- b. Grade #2 X**
- c. Grade #3
- d. Grade #4

10. Most manufacturers of vehicles equipped with diesel engines allow what type of biodiesel? (Text page 77)

- a. B100
- b. B80
- c. B20
- d. B5 X**

## **ASE / NATEF Correlation Charts**

1.

### **Suggestions for related instruction (web links / books / movies / etc.)**

1. <http://www.fuelmagic.net/Cetane%20Booster.html>
2. [http://www.engineeringtoolbox.com/specific-gravity-liquid-fluids-d\\_294.html](http://www.engineeringtoolbox.com/specific-gravity-liquid-fluids-d_294.html)
3. <http://www.make-biodiesel.org/RickDaTech-s-Blog/specific-gravity-and-biodiesel.html>

# Chapter 7

## Hybrid Auxiliary and High-Voltage Batteries

### Chapter Summary

1. When a flooded-type lead-acid battery is being discharged, the acid (SO<sub>4</sub>) is leaving the electrolyte and being deposited on the plates. When the battery is being charged, the acid (SO<sub>4</sub>) is forced off the plates and back into the electrolyte.
2. Flood-type lead acid batteries give off hydrogen and oxygen when being charged.
3. Auxiliary batteries are rated according to CCA and reserve capacity.
4. Auxiliary batteries can be tested with a voltmeter to determine the state of charge. A battery load test loads the battery to one-half of its CCA rating.
5. A good auxiliary battery should be able to maintain higher than 9.6 volts for the entire 15 seconds test period.
6. Auxiliary batteries can be tested with a conductance tester even if discharged.
7. A battery drain test should be performed if the battery runs down.
8. Be sure that a battery charger is unplugged from a power outlet when making connections to a battery.
9. NiMH batteries are the type most used in hybrid electric vehicles.
10. Lithium-ion (Li-ion) type batteries are used in some electric and plug-in electric vehicles.

### Key Terms

AGM 82 • alkaline 96 • Ampere hour 83 • Battery electrical drain test 87 • battery module 92 • CA 83 • CCA 83 • Cells 80 • Deep cycling 83 • Electrolyte 81 • Flooded cell batteries 82 • Gassing 80 • Gel battery 82 • Grid 80 • lithium-ion (Li-ion) 93 • IOD 87 • Load test 85 • metal hydride 91 • MCA 83 • Parasitic load test 87 • Recombinant battery 82 • Reserve capacity 83 • solid state 98 • SLA 82 • SLI 80 • SVR 82 • Thermistors 93 • VRLA 82 • Zinc-air 98

### Objectives

1. Prepare for ASE Electrical/Electronic Systems (A6) certification test content area "B" (Battery Diagnosis and Service).
2. Describe how auxiliary 12-volt and high-voltage hybrid vehicle batteries work (Page 81)
3. List battery ratings. (Page 83)
4. Describe deep cycling (Page 83)
5. List the safety precautions necessary when working with batteries (Page 99)
6. Explain how to safely charge a battery. (Page 86)
7. Describe how to perform a battery load test. (Page 87)
8. Explain how to perform a conductance test (Page 86)

9. Discuss how to jump start a vehicle safely. (Page 89)
10. Discuss hybrid electric vehicle auxiliary batteries (Page 87)
11. Explain the types of high-voltage batteries used in most hybrid electric vehicles. (Page 90)

## **Lecture Resources:**

### Search the Internet

1. Have the students use the Internet to research battery construction. Ask them to determine how changes in battery construction over the last century have made batteries stronger and more dependable. Ask students to share their findings with the class. (Page 79)
2. Have the students use the Internet to research watts-hours per kilogram. Ask the students to share their findings with the class. (Page 81)
3. Have the students use the Internet to research causes of battery failure. Have the students report on common causes of failure. What can be done to reduce common causes of battery failure? Ask students to prepare an audio-visual presentation (such as PowerPoint slides with script) of their findings for the class. (Page 82)
4. Have the students search the Internet to research vehicles that are hybrid electric vehicles and how many different types of electrical systems are used. Ask the students to share their findings with the class. (Page 90)
5. Have the students use the Internet to research series circuits. Ask them to check several sites and share the most common statements about series circuits with the class. (Page 91)
6. Have student research the Internet for companies that manufacture high voltage batteries. Ask them to share their findings with the class. (Page 92)
7. Have the students use the Internet to research the location of HV batteries in a typical hybrid electric vehicle. Ask them to share their findings with the class. (Page 94)
8. Have the students use the Internet to research Lithium-ion batteries and list applications using this technology. Ask the students to share their findings with the class. (Page 95)
9. Have the students use the Internet to research ASTM standard F496. What is the organization that sets this standard? What is the recommended sequence of

testing for gloves? Ask the students to report their findings to the class. (Page 96)

10. Have the students use the Internet to research nickel-metal hydride batteries and list some of its uses in industry. Ask the students to share their findings with the class. (Page 97)
11. Have the students use the Internet to research NiMH batteries and list applications using this technology. Ask the students to share their findings with the class. (Page 98)
12. Have the students use the Internet to research Zebra batteries. Ask students to share their findings with the class. (Page 99)
13. Have students use the Internet to research the chemical formulas for ZINC-AIR and Sodium-sulfur batteries. Ask the students to share their findings with the class (Page 100).

**ASSESS** – Provide the students with diagrams of a battery being discharged and charged. Ask the students to identify which diagram shows the charging process and which shows the discharging process. (Page 80)

**CROSS Curricular Activity: Science** Have the students research the chemical structure of a sulfuric acid molecule. Have students discuss how the electrolyte used in a battery charges as the battery is discharged and charged. (Page 81)

**CROSS Curricular Activity: Science** Demonstrate how baking soda neutralizes acid by mixing water solutions of baking soda and battery acid. Test the pH level of each solution to show the students how the level changes. (Page 83)

**ASSESS** – Have the students perform an open-circuit voltage test to determine battery condition. Grade students on correct connection of voltmeter leads and analysis of collected data. (Page 84)

**CROSS Curricular Activity: Science** Provide the students with sample specific gravity readings at certain temperatures and have them determine battery state of charge, taking into account temperature correction factors. (Page 85)

**ASSESS** – Have the students properly connect a set of jumper cables to a vehicle. Grade students on making the correct connection sequence and cable placement. (Page 86)

**Career Preparation-** Have the students research local battery suppliers, manufacturers, and or rebuilders. What special skills and tools are needed for



employees of these businesses? What is the average rate of pay? Ask students to share their finding with the class. (Page 87)

**ASSESS** – Have the students hook up a battery charger to charge a battery. Grade students on safe hookup procedures and proper charging rate selection. (Page 88)

**ASSESS** – Provide the students with a customer concern related to a battery problem. Have the students list test they would perform to isolate the problem. Grade students on their ability to provide a logical approach to identifying problems. (Page 89)

**CROSS Curricular Activity: Science** Have the students research temperature and vapor pressure effects of batteries. Ask the students to discuss how this affects HV batteries? (Page 93)

**ASSESS** – Have the students record radio presets and reset them after the battery has been disconnected. Grade students on their ability to correctly record and restore settings. (Page 96)

**ASSESS** – With problems prepared in advance, have students calculate variables by using formulas and give two of the three readings for each formula. Discuss the answers to measure student learning. (Page 100)

### **Additional Topics:**

1. <http://www.ehow.com/lead-acid-batteries/> (Page 79)
2. <http://video.ezinemark.com/nickel-cadmium-batteries-45baca39900.html> (Page 80)
3. <http://www.mpoweruk.com/nimh.htm> (Page 80)
4. [http://www.greencarcongress.com/2004/11/zincair\\_hybrid\\_.html](http://www.greencarcongress.com/2004/11/zincair_hybrid_.html) (Page 98)
5. <http://www.mpoweruk.com/zebra.htm>
6. <http://www.hybridinverter.com> (Page 80)
7. <http://www.powerstream.com/battery-isolator.htm> (Page 81)
8. [http://www.wisconsin.edu/oslp/em/compliance/battery\\_leadacid.htm](http://www.wisconsin.edu/oslp/em/compliance/battery_leadacid.htm) (Page 83)

### **Discuss**

1. Ask students to talk about the electricity requirements of a vehicle. How do developments in automotive technology affect electrical system and battery demands? (Page 79)

2. Ask the students to talk about the release of hydrogen and oxygen (gassing) during charging. Why might gassing be dangerous when working around an automotive battery? (Page 79)
3. **SAFETY-** Have the students access a material data safety sheet (MSDS) for an automotive battery to find safe handling instructions, first aid procedures, reactivity data, and so forth. Ask students to write a summary of the properties and procedures detailed in the MSDS and share their work with the class. (Page 79)
4. Discuss with the students how specific gravity measurement is based on a gravity reading at a specific temperature. How could changes in temperature affect a battery's specific gravity measurement? (Page 80)
5. **Hands-ON-** Have the students locate and read the charge indicator on a battery to determine state-of-charge. Have students explain the validity of charge indicated in determining battery state-of-charge. (Page 80)
6. Have students discuss the difference between CCA and CA ratings. What factors affect a battery's CCA and CA ratings? (Page 81)
7. Have the students discuss why normal batteries are not designed for repeated deep cycling. What types of vehicles are likely to use deep cycle batteries? (Page 81)
8. **Hands-ON-** Have the students locate and record different battery ratings on a battery. Have them discuss how those ratings can be used to provide testing data, or determine specifications for replacement batteries. (Page 82)
9. Have the students discuss reserve capacity and research reserve capacity specification published by manufacturers in a vehicle information system. Have students discuss the importance of having the correct reserve capacity battery rating. (Page 82)
10. **SAFETY-** Have the students discuss why distilled water is preferred over ordinary drinking water to fill an automotive battery. If distilled water is not available, what type of drinking water should be used? (Page 83)
11. **TIP-** Some nonservicable batteries appear to have removable caps. If these caps are pried off, the battery case and vents will be damaged, requiring battery replacement. (Page 83)
12. Have the students discuss the difference between dynamic and open circuit voltage. What happens if the dynamic voltage is lower than specified? (Page 84)

13. Have the students discuss the correlation between specific gravity, open-circuit voltage, and battery state of charge. How do you detect a defective battery? (Page 85)
14. Have the students talk about differences between open-circuit voltage and specific gravity when determining battery state of charge. Why might a technician prefer one or the other? (Page 86)
15. Have the students discuss the difference between battery load testing and conductance testing. What are the pros and cons of each? (Page 86)
16. **TIP-** When disconnecting batteries that are wired in series, make sure you disconnect the negative cable on the battery that is grounded first. (Page 86)
17. Have the students discuss the pros and cons of standard lead-acid, AGM, and gel batteries. Ask them which battery would be best suited for special applications such as off-road or recreational vehicles. (Page 87)
18. Have the students talk about AGM batteries commonly used when the battery is located inside the vehicle? (Page 88)
19. **TIP-** Be careful not to overtorque side-post batteries. Overtorquing may cause the post to twist, which in turn will cause the battery to leak acid. (Page 88)
20. Ask the students to discuss the difference between distilled water and bottled water. Why is distilled water used in a battery? (Page 88)
21. Ask the students to discuss the percentage of water in the acid solution of a battery. How is this percentage affected as the battery discharges? (Page 88)
22. Have the students discuss the difference between charging a battery and jump starting a vehicle with a dead battery. Why is charging the battery better than jump starting the vehicle? (Page 89)
23. **TIP-** Vehicles with harsh suspension characteristics may decrease battery life due to excessive vibration. To compensate, ensure that the battery is securely clamped down. (Page 89)
24. Have the students identify the different types of electrical systems in a hybrid electric vehicle. Note the safety features and safety labels. (Page 90)
25. Have students research the different types of battery charging systems for batteries. Ask the students to discuss their findings to the class. (Page 90)

26. Have the students talk about the voltage drop that occurs in a series circuit. What determines the voltage drop? (Page 91)
27. Have the students talk about the series circuit laws. What is the difference between current and voltage in a series circuit? (Page 91)
28. **TIP-** A circuit has to have current flowing in order to check voltage drop. (Page 92)
29. Have the students discuss the difference between a cell and a battery. Have them describe the differences between the two. (Page 92)
30. Have the students discuss the importance of monitoring battery temperature in a HV battery. (Page 93)
31. Have the students discuss the identifying colors used for high-voltage cables. What does blue or yellow mean? What does orange plastic conduit mean? (Page 93)
32. Have the students discuss how HV batteries are measured for state of charge. How is this different from the none HV battery? (Page 94)
33. **SAFETY-** Have the students talk about the need for safety precautions when working around and with hybrid electric vehicles. Both hybrid electric vehicles and all-electric vehicles use high-voltage circuits that cannot be touched without protection. (Page 94)
34. Ask students to discuss the difference between NiMH batteries and Lithium-ion batteries. What additional requirements do Lithium-ion batteries require over NiMH batteries? (Page 95)
35. Ask student to compare Ni-Cd batteries to Lithium-ion batteries. (Page 95)
36. Have students discuss why normal automotive batteries are not designed for repeated deep cycling. What types of vehicles are likely to use deep cycle batteries? (Page 95)
37. Discuss the advantages and disadvantages of zinc-air batteries. Have the students discuss the possible use of these batteries in electric vehicles. (Page 95)
38. Have student discuss the safety hazards associate with Sodium-sulfur batteries. discuss with the students that the ford "Ecostar" was the first vehicle to use this type of battery (Page 96)

39. **Hans-on-** Have the students find and decipher the date code on a battery to determine battery age. (Page 96)
40. Have the students talk about the importance of using leather gloves over insulated gloves. Remind them that when purchasing leather gloves, they must be large enough to fit over the insulated safety gloves. What should be done before each use of gloves? (Page 96)
41. **Hans-on-** Have the students wear insulated and leather gloves while trying to take a voltage reading using a CAT III multimeter. Ask the students to share their experience with the task. (Page 96)
42. Ask students to discuss the advantages of NICAD batteries and the disadvantages. Have student's research applications of this type of battery technology. (Page 97)
43. Discuss with the students the difference between alkaline battery and Lead-Acid batteries. (Page 97)
44. Discuss with the students lithium iron phosphate (LiFePO) and why it is a good source for a cathode in a battery. Have the student's research manufacturers who use this type of battery in hybrid electric vehicles. (Page 97)
45. Ask students to discuss the NiMH batteries. Why are these batteries so popular in hybrid electric vehicles? (Page 97)
46. Discuss with the students were sodium-metal-chloride batteries are used today. Have students debate the use of this technology in EV and HEV vehicles. (Page 99)
47. Have the students use the chart on page 99. Have them break into groups and pick one of the battery technologies. Each team needs to develop a presentation on their battery technology that explain why they should or shouldn't use this as a energy source in vehicles. (Page 99)
48. Ask students to compare Ohm's law and Watt's law. Which law can be used to determine the diameter of wire needed for a circuit? (Page 99)
49. **Hans-on-** prepare ten simple problems for students to solve involving Ohm's law. Explain the importance of the formulas used in solving the problems. Have students solve the problems and discuss their results. (Page 99)

## **Demonstrate**

1. Use AA batteries and a voltmeter to demonstrate battery construction. Show the students how voltage increases when batteries are connected in series versus parallel. (Page 79)
2. Show students different types of automotive batteries, focusing on characteristics that may be used to distinguish one from another. (Page 80)
3. Show the students the proper procedure for removing a surface charge. (Page 84)
4. Show students how to properly perform a battery load test to determine battery condition. (Page 85)
5. Show the students how to properly test a battery using a conductance tester. (Page 86)
6. Using a voltmeter, demonstrate how to find corroded and/or poor connections by measuring voltage drop. (Page 89)
7. Show the students how to jump start or charge a battery using remote access points. (Page 89)
8. Show the students how the temperature of a battery increases as a load is put on the battery. Use a battery load tester and Temperature gun or pyrometer to measure the temperature increase of the battery during load testing. (Page 93)
9. Use a lemon and two dissimilar metals to show battery cell operation. See how many cells it takes to light a bulb. Did you have to wire the cells in series or parallel? (Page 97)
10. Have examples of the five types of Lithium-ion batteries to show the students. Demonstrate the difference in construction to the students. (Page 98)
11. Show the students different types of automotive batteries, focusing on characteristics that may distinguish one from another. (Page 99)

## **Student Activities**

1. MAL chapter 50 Power Point (Page 106)
2. MAL Chapter 50.1 label battery components (Page 81)
3. MAL Chapter 50.1 Animation Chemical reaction in the battery during discharge (Page 80)
4. MAL Chapter 51.4 Video Load testing the battery (Page 88)

5. MAL Chapter 51.3 Video Measure parasitic draw (Page 89)
6. MAL Chapter 50 Diagnostic Assessment On a cold morning my vehicle has a long start time (Page 96)
7. MAL Chapter 50 NATEF Sheet Battery specifications (Page 88)
8. MAL Chapter 50 NATEF Sheet Battery and capacity test (Page 89)
9. MAL Chapter 50 NATEF Sheet Service and replacing the battery (Page 89)
10. MAL Chapter 50 NATEF Sheet Battery specifications (Page 88)
11. MAL Chapter 50 NATEF Sheet Jump Starting (Page 89)
12. MAL Chapter 50 NATEF Sheet Hybrid Auxiliary battery (Page 91)
13. MAL Chapter 90 NATEF Sheet Hybrid HV circuit disconnect (Page 94)
14. MAL Chapter 90 NATEF Sheet Identify HV of Hybrid electric vehicles (Page 96)

## Review Questions / Answers

1. Why can discharged batteries freeze? (Text page 82)  
**When a lead-acid battery discharges, the electrolyte becomes almost water which can freeze when exposed to cold weather.**
  
2. What are the battery-rating methods? (text page 83)  
**The typical battery ratings include cold cranking amperes (CCA), cranking amperes (CA), Marine cranking amperes (MCA), reserve capacity and ampere hour rating.**
  
3. What are the results of a voltmeter test of a battery and its state-of-charge? (Text page 85)  
**After the surface charge has been removed the battery voltage and state-of-charge (SOC) includes:**  
  
**12.6+ volts = 100%**  
  
**12.4 volts = 75%**  
  
**12.2 volts = 50%**

**12.0 volts = 25%**

**Less than 11.9 volts = discharged**

4. What are the steps for performing a battery load test? (Text page 85)

**To perform a battery load test, take the following steps:**

**STEP 1 Determine the CCA rating of the battery. The proper electrical load used to test a battery is one-half of the CCA rating or three times the ampere-hour rating, with a minimum 150 ampere load.**

**STEP 2 Connect the load tester to the battery. Follow the instructions for the tester being used.**

**STEP 3 Apply the load for a full 15 seconds. Observe the voltmeter during the load testing and check the voltage at the end of the 15-second period while the battery is still under load. A good battery should indicate above 9.6 V.**

**STEP 4 Repeat the test. Many battery manufacturers recommend performing the load test twice, using the first load period to remove the surface charge on the battery and the second test to provide a more true indication of the condition of the battery.**

**Wait 30 seconds between tests to allow time for the battery to recover. Results: If the battery fails the load test, recharge the battery and retest. If the load test is failed again, the battery needs to be replaced.**

5. What battery types are most used in electric and hybrid electric vehicles? (Text pages 90; 93)

**Nickel-metal hydride (NiMH) battery and lithium-ion (Li-ion) technology are the two types of high-voltage batteries used today in hybrid electric and electric vehicles.**

#### **CHAPTER QUIZ QUESTIONS AND ANSWERS:**

1. When an auxiliary battery becomes completely discharged, both positive and negative plates become \_\_\_\_\_ and the electrolyte becomes \_\_\_\_\_. (Text page 82)
- H<sub>2</sub>SO<sub>4</sub>/Pb
  - PbSO<sub>4</sub>/H<sub>2</sub>O X**
  - PbO<sub>2</sub>/H<sub>2</sub>SO<sub>4</sub>
  - PbSO<sub>4</sub>/H<sub>2</sub>SO<sub>4</sub>



2. Deep cycling means \_\_\_\_\_.(Text page 83)
- a. Overcharging the battery
  - b. Overfilling or under filling the battery with water
  - c. The battery is fully discharged and then recharged X**
  - d. The battery is overfilled with acid (H<sub>2</sub>SO<sub>4</sub>)
3. Which battery rating is tested at 0°F (-18°C)? (Text page 83)
- a. Cold-cranking amperes (CCA) X**
  - b. Cranking amperes (CA)
  - c. Reserve capacity
  - d. Battery voltage test
4. Which battery rating is expressed in minutes? (Text page 83)
- a. Cold-cranking amperes (CCA)
  - b. Cranking amperes (CA)
  - c. Reserve capacity X**
  - d. Battery voltage test
5. What battery rating is tested at 32°F (0°C)? (text page 83)
- a. Cold-cranking amperes (CCA)
  - b. Cranking amperes (CA) X**
  - c. Reserve capacity
  - d. Battery voltage test
6. When load testing a battery, which battery rating is often used to determine how much load to apply to the battery? (Text page 85)
- a. CA

- b. RC
- c. MCA
- d. CCA X**

7. A battery high-rate discharge (load capacity) test is being performed on a 12-volt battery. Technician A says that

a good battery should have a voltage reading of higher than 9.6 volts while under load at the end of the 15 seconds. test. Technician B says that the battery should be discharged (loaded) to twice its CCA rating. Which technician is correct? (Text page 85)

**a. Technician A only X**

- b. Technician B only
- c. Both technicians A and B
- d. Neither technician A nor B

8. When charging a lead-acid (flooded-type) battery, \_\_\_\_\_. (Text page 86)

- a. The initial charging rate should be about 35 amperes for 30 minutes
- b. The time is determined by the reserve capacity divided by the charge current
- c. The battery temperature should not exceed 125°F (hot to the touch)

**d. All of the above X**

9. Where are AGM auxiliary batteries usually located in a hybrid electric vehicle? (Text page 88)

- a. Under the hood
- b. In the trunk/rear area X**
- c. Under the front fender
- d. Under the front seat

10. Which type of battery is most used in hybrid electric vehicles? (Text page 90)

a. Nickel-Metal Hydride X

b. Lithium-Ion

c. Nickel-Cadmium

d. Sodium-Nickel Chloride

## ASE / NATEF Correlation Charts

1.

### Suggestions for related instruction (web links / books / movies / etc.)

1. <http://www.powerstream.com/NiMH.htm>
2. <http://www.thermoanalytics.com/support/publications/batterytypesdoc.html>
3. <http://www.greencar.com/articles/ford-ecostar-ev.php>
4. [http://navyaviation.tpub.com/14014/css/14014\\_154.htm](http://navyaviation.tpub.com/14014/css/14014_154.htm)
5. <http://www.carbuyingtips.com/jumpstart.htm>
6. [http://www.ehow.com/video\\_4754043\\_charge-car-battery.html](http://www.ehow.com/video_4754043_charge-car-battery.html)

# Chapter 8

## Electric Motors, Generators, and Controls

### Chapter Summary

1. Magnetic lines of force leave the north pole and enter the south pole of a magnet.
2. Magnetic lines of force are called flux lines.
3. Any conductor carrying an electrical current generates a magnetic field across a conductor creates electricity.
4. Like poles repel and unlike poles attract.
5. A business DC motor is also known as an AC synchronous motor.
6. Powerful permanent magnets are used in the rotors of DC brushless motors.
7. The operation of motors is performed by the controller, which is capable of switching the voltage and/or the frequency of the current flowing through the stationary windings of the motor.
8. DC-DC converters are used in hybrid electric vehicles to convert the high-voltage battery current into a lower voltage used by the accessories and lighting systems.

### Key Terms

• ACIM 108 • AC Induction motor 108 • AC motor 110 • Armature 108 • Brushless motor 108 • Commutator 108 • DC motor 108 • Electrical noise 108 • Electromagnetics 104 • Electromagnetism 104 • EPS 118 • Flux 103 • hp 107 • IGBT 112 • Inverter 117 • IPM 109 • kW 107 • Lenz's law 107 • Lodestone 102 • Magnetism 102 • MOSFET 117 • PDU 111 • Permeability 104 • Pole 103 • PWM 110 • Reluctance 104 • Resolver 113 • Right-hand rule 104 • Rotor 107 • Senseless DC motor 109 • SPM 109 • Squirrel-cage rotor 108 • Stator 107

### Objectives

1. Describe the operation of DC and AC electric motors. (Pages 108)
2. Explain how a brushless DC motor works.(Page 108)
3. Discuss the advantages and disadvantages of using electric motors in hybrid electric vehicles. (Page 1110)
4. Explain how electric power steering works. (Page 118)

5. Describe how a DC-to-DC converter works. (Page 116)
6. Discuss how a DC-to-AC inverter works. (Page 117)

## **Lecture Resources:**

### Search the Internet

1. Have the students use the Internet to research magnetite. Where is magnetite found? How it is mined? How is it used? Is mining magnetite a small or large industry? Ask students to report their findings to the class. (Page 102)
2. Have the students use the Internet to research permeability of materials. Have them develop a table that list 12 materials and their permeability values. Ask them to include low- and high-permeability materials in their tables. Have students share their table with the class. (Page 103)
3. Have the students use the Internet to research magnetic induction and the work of Michael faraday. Ask students to share their findings with the class. (Page 106)
4. Ask the students to research who invented the first electric motor. When was it invented? What was it used for? Have the students write a report on their findings. Ask them to present their findings to the class. (Page 107)
5. Have the students use the Internet to research brushless motors. Ask the students to share their findings with the class. (Page 109)
6. Have the students use the Internet to research permanent magnet rotors. Ask the students to share their findings with the class. (Page 110)
7. Have the students use the Internet to research Honda motor company for green technologies. Ask the students to share their findings with the class. (Page 112)
8. Have the students use the Internet to research the Leyden jar. Ask them to write a report about the construction of the original jar and the scientists who constructed it, as well as later modifications. Ask students to share their findings with the class. (Page 115)
9. Have the students use the Internet to further research capacitors. Ask them to look specifically for super capacitors and capacitor battery combinations. What are their benefits? Have the students report their findings to the class.(Page 116)

10. Have the students use the Internet to research DC-DC convertors and their applications in automotive circuits. Ask the students to write a report and share their findings with the class. (Page 117)
11. Have the students use the Internet to research hybrid vehicles. Why do hybrid vehicles use AC motors instead of DC motors? Ask students to report their findings to the class. (Page 117)
12. Have the students use the Internet to research the history of electric power steering systems. The students should include information on the need for these systems, when they were introduced, what manufacturers first used them, etc. (Page 118)
13. Have the students use the Internet to research electric power steering systems and hydraulic steering systems. Ask them to compare the two systems, listing the advantages and disadvantages of each system. (Page 119)

**CROSS Curricular Activity: History-** Have the students research the history of electromagnetism. Have them list the names of scientist(s) who discovered and worked with electromagnetism. Ask students to report their findings to the class. (Page 104)

**ASSESS –** Have the students determine magnetic field direction on nonworking examples of simple electromagnets constructed of one-foot sections of wooden dowel rod and scrap wiring. Mark the ends --- and + and have the students apply the right-hand rule. Grade students on their ability to complete the task. (Page 105)

**ASSESS –** Have the students compare and contrast different types of electric motors. Grade them on their understanding of operation, differentiations, and efficiency. (Page 108)

**ASSESS –** Have the students use the electronic repair information system to research hybrid electric vehicles for electric motor usage. Have them prepare a presentation on their findings to share with the class. (Page 111)

**CROSS Curricular Activity: History-** Have the student look up B. Jayant Baliga on the Internet. Have them prepare a presentation on their findings to present to the class. (Page 113)

**CROSS Curricular Activity: Math-** Have the students research the price of gold and copper. Have them calculate the cost increase of a car if 10 pounds of gold were to be used for wiring instead of 10 pounds of copper. Ask the students to share and compare their findings and calculations with other class members. (Page 114)

**ASSESS** – have students discuss the effects of EMI on the vehicles electrical systems. Have them give examples of the possible effects of EMI. Have them share their ideas with the class. (Page 117)

**ASSESS** – have the students summarize the components and inputs/outputs of an electronic power steering (EPS) system. Grade the summaries on thoroughness and accuracy. (Page 119)

**ASSESS** – Have the students write a report on why manufacturers are using electronic power steering. Give students credit for clearly describing the reasons by using correct sentence structure and grammar. (Page 119)

### **Additional Topics:**

1. <http://science.howstuffworks.com/magnet.htm>
2. [http://missionscience.nasa.gov/ems/02\\_anatomy.html](http://missionscience.nasa.gov/ems/02_anatomy.html)
3. [http://www.ehow.com/facts\\_7708489\\_dc-vs-ac-electric-motor.html](http://www.ehow.com/facts_7708489_dc-vs-ac-electric-motor.html)
4. [http://en.wikipedia.org/wiki/Faraday%27s\\_law\\_of\\_induction](http://en.wikipedia.org/wiki/Faraday%27s_law_of_induction)
5. [http://en.wikipedia.org/wiki/Brushless\\_DC\\_electric\\_motor](http://en.wikipedia.org/wiki/Brushless_DC_electric_motor)
6. [http://en.wikipedia.org/wiki/Brushless\\_DC\\_electric\\_motor](http://en.wikipedia.org/wiki/Brushless_DC_electric_motor)
7. [http://en.wikipedia.org/wiki/Insulated-gate\\_bipolar\\_transistor](http://en.wikipedia.org/wiki/Insulated-gate_bipolar_transistor)
8. [http://en.wikipedia.org/wiki/Insulated-gate\\_bipolar\\_transistor](http://en.wikipedia.org/wiki/Insulated-gate_bipolar_transistor)

### **Discuss**

1. Have the students discuss magnetism. Which materials can be magnetized, and which cannot? (Page 102)
2. Have the students how a cracked magnet becomes two magnets. What problems result from a cracked magnet? (Page 102)
3. Have the students discuss permeability. Why is there a need for permeability in automotive applications of magnets? (Page 103)
4. Have the students discuss electromagnetism. Ask them to name several types of electromagnets. (Page 104)

5. **Hands-on-** Have the students build their own electromagnets. Let them try more than on battery, more turns of wire, or a larger core. Have them document the strength of each version of the electromagnet to decide what produces a stronger magnet and what does not. (Page 104)
6. Have the students talk about the right-hand rule of magnetism. Which rule is used to determine the direction of the magnetic flux lines in most automotive circuits/ (Page 105)
7. Have the students talk about electromagnetic strength. In what ways can electromagnetic strength be increased? How can the strength of a handmade electromagnet be increased? (Page 105)
8. Have the students discuss electromagnetic induction. What three items are necessary to produce electricity from magnetism? Have the students talk about the four ways to increase induced voltage. Can these ways be used alone and together? (Page 106)
9. Ask the students to discuss Lenz's law and counterelectromotive force. According to Lenz's law, how does self-induced voltage react to the current that produces it? (Page 106)
10. Have the students talk about mutual induction, in what automotive applications is mutual induction used? (Page 106)
11. Have the students talk about wear on the parts of a motor. Which parts typically wear out? (Page 108)
12. **Hands-on-** Have the students disassemble an electric motor to inspect its components. (Page 108)
13. Discuss with students the students the AC motor designs A and B, C, D, F. reference  
[http://www.electricmotors.machinedesign.com/guiEdits/Content/bdeee2/bdeee2\\_1-1.aspx](http://www.electricmotors.machinedesign.com/guiEdits/Content/bdeee2/bdeee2_1-1.aspx) (Page 109)
14. Have the students discuss the different types of AC motor designs. Ask students to give advantages and disadvantages for each type of design. (Page 109 )
15. Discuss DC-excited electric motors with the students. Ask the students to look up DC-excited electric motors and prepare a summary of applications for this type of electric motor. (Page 110)



16. **Hands-ON-** Prepare some horsepower engine rating and KW rating for electric motors and have the students convert them to KW and HP. Have them discuss the different ratings and the potential for work. (Page 111)
17. Review with the students the different methods of propulsion. What two common combinations are being used to classify vehicles as hybrids? (Page 111)
18. Discuss with the students figure 8-22. Compare the torque and power output of and electric motor and a typical gasoline engine. Have the students discuss the difference in torque curves versus RPM. (page 112)
19. Discuss the details of how a PDU operates in a Honda hybrid electric vehicle. Have the students use the schools vehicle information system to research the different modes of operation. (Page 112)
20. Have the students discuss different conductors. Why is copper the most commonly used conductor in the electrical systems of vehicles/ (Page 113)
21. Have the students discuss insulators and the reason they make poor conductors. What is the relationship between the number of electrons an insulator material has and its ability to acquire and release electrons? (Page 145)
22. Have the students use the vehicle information system to research vehicles that use motors to operate drive line components. Have the students share their findings with the class. (Page 114)
23. **SAFETY-** Inform the students that, because a capacitor stores electricity, it can deliver a shock to a person. (Page 115)
24. **TIP-** Be sure that capacitors are fully discharged before working near them. (Page 115)
25. Have the students discuss the three factors of capacitance. How does the dielectric material affect capacitance? (Page 116)
26. Ask the students to discuss the use of capacitors to eliminate radio interference. How does this principle work? What type of current cause radio interference? (Page 116)
27. Have the students discuss the use of capacitors in parallel. How is this connection procedure similar to or different from connecting resistors in parallel/ (Page 116)

28. Have students discuss DC-DC converters. What are some examples of their use in automotive systems? (Page 117)
29. **TIP-** Use a diagnostic scanner and read engine data to show the students the 5 V power supply reading in an engine control circuit. (Page 117)
30. **SAFETY-** Always use proper precautions to avoid shock or injury when working around, or testing, any circuits that are connected to a DC-DC converter. (Page 117)
31. Have the students talk about DC-DC converter circuit testing. What is used to test DC-DC converter circuits? (Page 118)
32. Have students discuss inverters. How does an inverter transform DC current to AC current? What is the difference between a modified sine wave and a true sine wave? (Page 118)
33. Have the students discuss electrostatic discharge. What are ways to avoid ESD damage? (Page 119)
34. **TIP-** Become familiar with servicing procedures for electric power steering units. Many vehicles now include them, and more vehicles will be including them in the near future. (Page 118)
35. **TIP-** Power steering fluid is considered hazardous. Be sure to properly dispose of it. (Page 119)

## **Demonstrate**

1. Show the students how to magnetize a small object such as a nail or paper clip. Have students magnetize a small object. (Page 102)
2. Show the students how a magnet affects material like aluminum, copper, Iron, and steel. Talk about why the materials are, or are not attracted to the magnet. (Page 103)
3. Use a crankshaft sensor and a digital ammeter to show the students how crankshaft sensors produce a small AC voltage when a metal object passes by it. Have students create the voltage by waving a metal object close to the sensor. (Page 103)
4. Wrap a number 16 nail with 20 turns of insulated wire. Connect the ends of the wire to a D cell battery. Show the students how the nail is now a magnet and can pick up small metal objects. (Page 104)

5. Demonstrate the right-hand and left-hand rules of magnetism to the students. (Page 105)
6. Show the students how to inspect an armature using an ohmmeter. (Page 108)
7. Show the students a permanent magnet starter and rotor. Explain who the work in this application.(Page 110)
8. Demonstrate to the students that electrical current will not pass through plain water: then add salt to the water to show the effect on current flow. (Page 113)
9. Show the students several different types of capacitors that are used in automotive applications. (Page 115)
10. Show the students a set of points and a condenser (Capacitor) for a distributor-type ignition system. Cut apart a capacitor and show students the material inside. (Page 116)
11. Demonstrate the formula for calculating capacitance isn a circuit with capacitors connected in parallel. Have the students calculate capacitance in parallel circuits.  $C_T = C_1 + C_2 + C_3 + \dots$  (Page 117)
12. Show the students examples of electric power steering (EPS) assemblies. (Page 118)
13. Show the students an example of a Honda electric power steering unit. (Page 118)
14. Show the students an example of a power steering control module (PSCM). (Page 118)
15. Show the students an example on a scan tool and explain how it works. (Page 118)
16. Show the students several examples of power steering filters. (Page 119)
17. Show the students examples of power steering analyzers. (Page 119)
18. Show the students how to connect a power steering analyzer to a power steering system. (Page 119)
19. Show the students examples of the sensors used in self-parking units. (Page 119)

## **Student Activities**

1. MAL Chapter 47 Power Point chapter 47 (Page 102)
2. MAL Chapter 47.1 Animation Applying electromagnetism in a relay (Page 135)
3. MAL Chapter 46.2 Animation Using a Capacitor as a noise suppresser (Page 146)
4. MAL Chapter 47 NATEF Task Sheet Inspect and Test Relays (page 103)
5. MAL Chapter 48 NATEF Task Sheet Electronic Fundamentals (Page 104)
6. MAL Chapter 49 NATEF Task Sheet Module Communications. (Page 112)
7. MAL Chapter 52.2 Activity Label the parts of a starter motor (Page 108)
8. MAL Chapter 48 Power Point Chapter 48 (Page 117)
9. MAL Chapter 118 Power point Chapter 118 (Page 118)
10. MAL Chapter 118 Activity Label the parts of a Power rack-and-pinion steering system (Page 119)

## Review Questions / Answers

1. How is an electrical current induced in a wire? (Text page 104)  
**Whenever a magnetic field is moving near a conductor, such as a wire, a difference in voltage potential is created between the ends of the wire. If the wire is connected to a complete circuit, current will flow.**
2. How does an AC synchronous motor work? (Text page 109)  
**A DC motor can function without brushes by using a permanent magnet rotor. Because the rotor has north and south magnetic poles, it is able to function without brushes.**
3. How does an AC induction motor work? (Text page 108)  
**An AC induction motor works by using electromagnetic induction to create a magnetic field in the rotor which is wire wound.**
4. How is the operation of a brushless DC motor controlled? (Text pages 111-113)  
**The operation of a brushless DC or AC motor is controlled by an electronic controller using input from the rotor position sensor or resolver to pulse the current through the stator windings. The speed is**

**controlled by varying the frequency and the power is controlled by varying the voltage and the pulse width.**

5. What is a DC-DC converter, and why is it needed in a hybrid electric vehicle? (Text page 116)  
**A DC-DC converter is used to convert the DC voltage from one level to another. A DC-DC converter is used to charge the 12-volt auxiliary battery from the high-voltage (HV) batteries.**

#### CHAPTER QUIZ QUESTIONS AND ANSWERS:

1. All of the following statements are true *except* \_\_\_\_\_. (Text page 103)
- a. **The magnetic lines of force leave the south pole and enter the north pole X**
  - b. Around every conductor carrying a current is a magnetic field
  - c. Magnetic lines of force never intersect
  - d. The higher the current through a conductor the stronger the magnetic flux
2. Technician A says that some DC motors use brushes. Technician B says that an AC synchronous motor uses a permanent magnet rotor. Which technician is correct? (Text pages 108-109)
- a. Technician A only
  - b. Technician B only
  - c. **Both Technicians A and B X**
  - d. Neither Technician A nor B
3. The power of most electric motors is expressed in \_\_\_\_\_. (Text page 111)
- a. Horsepower
  - b. **kW X**
  - c. Watts
  - d. Amperes

4. AC synchronous motors used in hybrid electric vehicles use how many windings in the stationary part of the motor? (Text pages 111-112)
- a. One
  - b. Two
  - c. Three X**
  - d. Four X
5. Technician A says that a traction (AC synchronous) motor used in a hybrid electric vehicle is controlled by varying the voltage to the motor. Technician B says that the frequency of the current is controlled. Which technician is correct? (Text page 111)
- a. Technician A only
  - b. Technician B only
  - c. Both Technicians A and B X**
  - d. Neither Technician A nor B
6. Technician A says that a DC-to-DC converter is used to convert 12 volts from the battery to a higher voltage to run the electric motor(s) in a hybrid electric vehicle. Technician B says that a DC-to-DC converter is used to convert the voltage from the motor/generator to a higher voltage to charge the high-voltage batteries. Which technician is correct? (Text page 116)
- a. Technician A only
  - b. Technician B only
  - c. Both Technicians A and B
  - d. Neither Technician A nor B X**
7. What type of electric motor is used for the traction motor in most hybrid electric vehicles? (Text pages 108-109)
- a. DC brush-type motor

- b. AC induction-type motor
- c. Brushless DC motor
- d. Both b and c are used X**

8. The \_\_\_\_\_ are used to rectify AC to DC current. (Text page 112)

- a. Transistors
- b. Diodes X**
- c. Capacitors
- d. Condensers

9. What is the most common type of rotor used in an AC synchronous motor? (Text page 109)

- a. Wire wound
- b. Permanent magnet X**
- c. Squirrel-cage
- d. Both b and c

10. Current sensors are commonly used by the motor controller to help with the tasks of motor management. What

type of sensor is usually used for this task? (Text page 112)

- a. Hall-effect X**
- b. Potentiometer
- c. Wheatstone bridge
- d. Piezoelectric

## ASE / NATEF Correlation Charts

1.

**Suggestions for related instruction (web links / books / movies / etc.)**

1. [http://www.electricmotors.machinedesign.com/guiEdits/Content/bdeeee2/bdeeee2\\_1.aspx](http://www.electricmotors.machinedesign.com/guiEdits/Content/bdeeee2/bdeeee2_1.aspx)
2. <http://electronics.howstuffworks.com/brushless-motor.htm>
3. [http://www.toyota.com/sem/hybrids.html?srchid=K1263\\_p3207096191](http://www.toyota.com/sem/hybrids.html?srchid=K1263_p3207096191)
4. [http://www.chevrolet.com/volt-electric-car/?seo=msn | 2008 Chevy Retention | IMG Chevy Volt | Chevy Volt | \\_chevy\\_volt&utm\\_source=MSN&utm\\_medium=cpc&utm\\_campaign=Retention-Chevy-IMG Chevy Volt&utm\\_content=Search&utm\\_term=chevy\\_volt](http://www.chevrolet.com/volt-electric-car/?seo=msn|2008%20Chevy%20Retention|IMG%20Chevy%20Volt|Chevy%20Volt|_chevy_volt&utm_source=MSN&utm_medium=cpc&utm_campaign=Retention-Chevy-IMG%20Chevy%20Volt&utm_content=Search&utm_term=chevy_volt)
5. <http://www.ford.com/suvs/escape/?searchid=30666037|344152742|5954313788>

## Chapter 9 Regenerative Braking Systems

### Chapter Summary

1. All moving objects that have mass (weight) have kinetic energy.
2. The regenerative braking system captures most of the kinetic energy from the moving vehicle and returns this energy to high-voltage batteries to be used later to help propel the vehicle.
3. The two types of regenerative braking include parallel and series.
4. Brushless DC and AC induction motors are used in hybrid electric vehicles to help propel the vehicle and to generate electrical energy back to the batteries during braking.
5. Most hybrid electric vehicles use an electrohydraulic braking system that includes pressure sensors to detect the pressure in the system.
6. The controller is used to control the motor and turn them into a generator as needed to provide regenerative braking.

### Key Terms

Base brakes 122 • Brake pedal position (BPP) 125 • Electrohydraulic brake (EHB) 123 •  $F = ma$  121 • Force 121 •  $G$  128 • Inertia 121 • Kinetic energy 121 • Mass 121 • Regen 122 • Regeneration 122 • Torque 121



## Objectives

1. Describe how regenerative braking works. (Page 121)
2. Explain the principles involved in regenerative braking. (Page 122)
3. Discuss the parts and components involved in regenerative braking systems. (Page 126)
4. Describe the serving precautions involved with regenerative brakes. (Page 129)

## Lecture Resources:

### Search the Internet

1. Have the students use the Internet to research regenerative braking systems first use. Ask students to discuss their research with the class. (Page 123)
2. Have the students use the Internet to research permanent-magnet motors used in trolley cars. Ask the students to discuss their research with the class. (Page 124)
3. Have the students use the Internet to research the proper battery charge rate for hybrid electric vehicles. Ask the students to discuss their research with the class. (Page 125)
4. Have the student's use the Internet to research manufacturers' projected conventional brake pads, and brake shoe replacement or service intervals are for hybrid electric vehicle. Have the students compare the recommended brake service interval with a none hybrid electric vehicle. Ask them to share their findings with the class. (Page 126)
5. Have the students use the Internet to research "Green Driving" habits. Have the students create a PowerPoint to share their findings on Green Driving with the class. (Page 127)
6. Have the students' research hybrid electric vehicle accidents statistics. Ask the students to share their finding with the class. (Page 129)

## Cross-Curriculum Activity: Mathematics

Have the students calculate the Kinetic energy of a 3,500-lb vehicle moving at 45 mph. then have them calculate the Kinetic energy of a 4,000-lb vehicle moving at 30 mph. Which vehicle has the greater kinetic energy? (Page 121)

**ASSESS** – Have the students write a paper comparing the relationship between mass, weight, and inertia. How is each factored into brake design? Grade students on making the proper connection between these principles. (Page 122)

**ASSESS** – Have the students disable a hybrid electric vehicle high voltage system and operate an on-the-car brake lathe on the vehicle. Grade the students on following safety procedures and proper insulation of the brake lathe. (Page 128)

### Cross-Curriculum Activity: Mathematics

Have the students calculate deceleration rates of different types of vehicles. Use the speed difference and time method, use the speed difference and distance method, and use the deceleration in gravity units. Reference website:

[http://www.ehow.com/how\\_6081657\\_calculate-deceleration.html](http://www.ehow.com/how_6081657_calculate-deceleration.html) (Page 128)

#### Additional Topics:

1. <http://www.hybridcars.com/components/regenerative-braking.html> (Page 122)
2. [http://www.windstreampower.com/Permanent\\_Magnet\\_DC\\_Generators.php](http://www.windstreampower.com/Permanent_Magnet_DC_Generators.php) (page 124)
3. <http://www.csgnetwork.com/batterychgcalc.html> (page 125)
4. <http://auto.howstuffworks.com/fuel-efficiency/fuel-economy/ten-green-driving-tips.htm> (Page 127)
5. <http://hybridcars.einnews.com/247pr/250061> (Page 129)

#### Discuss

1. Ask students to discuss the principles of kinetic energy and how they apply to automobile operation. (Page 121)
2. Ask students to talk about the relative braking power required when vehicle A weighs one-half as much as vehicle B. What about when vehicle A can go twice as fast as vehicle B? (Page 121)

3. Ask students to discuss the principles of inertia. How does inertia apply to automobile operation? (Page 122)
4. Hands-on- Have the students demonstrate the principles of leverage by setting up first-class, second-class and third-class levers. A brake pedal is an example of what type of lever? (Page 122)
5. Have the students research the schools automotive repair information system for vehicles with electrohydraulic brake (EHB) systems. Have them prepare a presentation of their findings to share with the class. (Page 123)
6. Have the students compare the advantages and disadvantages to series regeneration and Parallel regeneration. (Page 123)
7. Have the students discuss the history of regenerative braking technology and how this technology is used in the rail road industry. (Page 124)
8. Have the students discuss the limitations of regenerative brakes. Ask them to discuss the battery charge rate and compare it to a conventional battery charging system. (page 125)
9. Have the students use the school automotive repair system and look-up manufacturers' types of displays to inform drivers about regenerative braking, battery state-of-charge, and power usage. Ask the students to share their findings with the class. (Page 125)
10. Have the students discuss figure 9-6 and explain the difference between this brake system in figure 9-6 and a none hybrid brake system. (Page 126)
11. Have the students discuss the role of the ABS system in a regenerative brake system. (Page 126)
12. Have the students consider the benefits or drawbacks concerning the cost of a vehicle versus fuel savings. How long will you need to drive a vehicle with fuel savings in order to offset its extra cost as compared to driving an internal combustion engine vehicle? (Page 127)
13. Show the students a regenerative brake system on a hybrid electric vehicle. Remind students to use insulated tools when working on vehicles with high voltage. (Page 127)
14. Have students discuss how the regenerative brake system works and compare the methods used by different manufacturers'. (Page 128)

15. Have the students talk about the function of the generator, or motor used in hybrid vehicles. How can an alternator also function as a motor? (Page 128)
16. Discuss with students Honda VTEC technology and how it is applied in hybrid vehicles and none hybrid vehicles. (Page 128)
17. Discuss with students the Atkinson cycle used in hybrid technology vehicles. (page 128)
18. Discuss regenerative brake service precautions with students. Explain the importance of researching the manufactures precautions before performing any brake service work. (Page 129)

## Demonstrate

1. Down load this document to build a regenerative bicycle to demonstrate how regenerative braking works:  
<http://www.docstoc.com/docs/79329353/Regenerative-Braking-System-for-an-Electric-Bicycle#> (Page 124)
2. Use a screwdriver, a battery, and a length of wire to build an electromagnet. Explain to the students how it works. (Page 124)
3. Demonstrate to the students how the temperature of a battery is affected by the rate of charge. (Page 125)
4. Using the schools vehicle repair information system look up hybrid electric vehicle service precautions. Point out to the students how to find this information. (page 128)

## Student Activities

1. MAL Chapter 13 Power Point (Page 121)

## Review Questions / Answers

1. What is inertia? (Text page 121)  
**Inertia is the kinetic energy of a moving object that resists being put into motion and has a tendency to remain in motion unless acted on by an outside source.**
2. What is the difference between series and parallel regenerative braking systems? (Text page 123)

**In a series regenerative braking system, the amount of regeneration is proportional to the brake pedal position. In a parallel regenerative braking system, the base brakes are used along with regenerative braking and is proportional to vehicle speed rather than brake pedal position.**

3. What happens in the regenerative braking system when the high-voltage batteries are fully charged? (Text page 129)  
**If the batteries are charged to the specified maximum and braking occurs on a vehicle equipped with regenerative brakes, the braking forces from the base brakes are used to slow and/or stop the vehicle.**
  
4. Describe what occurs when the driver first releases the accelerator pedal and then starts to brake on a hybrid electric vehicle equipped with regenerative braking. (Text page 125)  
**When the driver releases the accelerator pedal, regenerative braking is being used to slow the vehicle slightly. When the brake pedal is depressed, the brake forces increase in proportion to the distance and pressure applied to the brake pedal by the driver.**

#### **CHAPTER QUIZ QUESTIONS AND ANSWERS:**

1. Which type of regenerative braking system uses an electro-hydraulic system? (Text page 123)
  - a. **Series X**
  - b. Parallel
  - c. Both series and parallel
  - d. Neither series nor parallel
  
2. Kinetic energy is \_\_\_\_\_. (Text page 121)
  - a. The energy that the driver exerts on the brake pedal
  - b. The energy needed from the batteries to propel a vehicle
  - c. **The energy in any moving object X**
  - d. The energy that the motor produces to propel the vehicle
  
3. Inertia is \_\_\_\_\_. (Text page 121)
  - a. **The energy of any moving object to continue moving in a straight line X**
  - b. The force that the driver exerts on the brake pedal during a stop
  - c. The electric motor force that is applied to the drive wheels
  - d. The force that the internal combustion engine and the electric motor together apply to the drive wheels during rapid acceleration

4. Technician A says that the Powertrain Control Module (PCM) or controller can control the voltage to the motor(s) in a hybrid electric vehicle. Technician B says that the PCM or controller can control the electric motors by varying the frequency of the applied current. Which technician is correct? (Text page 163)
- a. Technician A only
  - b. Technician B only
  - c. Both Technicians A and B X**
  - d. Neither Technician A nor B
5. During braking on a hybrid electric vehicle equipped with a regenerative braking system, what occurs when the driver depresses the brake pedal? (Text page 125)
- a. The friction brakes are only used as a backup and are not used during normal braking.
  - b. The motors become generators. X**
  - c. The driver needs to apply a braking lever instead of a depressing the brake pedal to energize the regenerative braking system.
  - d. The batteries are charged to 100% SOC.
6. Technician A says that a FWD hybrid electric vehicle can only generate electricity during braking from the front wheel motor(s). Technician B says that antilock braking (ABS) is not possible with a vehicle equipped with a regenerative braking system. Which technician is correct? (Text page 124)
- a. Technician A only X**
  - b. Technician B only
  - c. Both Technicians A and B
  - d. Neither Technician A nor B
7. In a regenerative braking system, which part of the electric motor is being controlled by the computer? (Text page 124)
- a. The rotor
  - b. The stator X**
  - c. Both the rotor and the stator
  - d. Neither the rotor nor the stator

8. In a Toyota Prius regenerative braking system, how many pressure **sensors** are used? (Text page 126)
- a. One
  - b. Two
  - c. Three
  - d. **Four X**
9. In a Toyota Prius regenerative braking system, how many pressure **switches** are used? (Text page 126)
- a. One
  - b. **Two X**
  - c. Three
  - d. Four
10. Two technicians are discussing deceleration rates. Technician A says that a one “g” stop is a gentle slowing of the vehicle. Technician B says that a stopping rate of 8 ft per second per second is a severe stop. Which technician is correct? (Text page 128)
- a. Technician A only
  - b. Technician B only
  - c. Both Technicians A and B
  - d. **Neither Technician A nor B X**

## ASE / NATEF Correlation Charts

1.

### Suggestions for related instruction (web links / books / movies / etc.)

1. <http://auto.howstuffworks.com/auto-parts/brakes/brake-types/regenerative-braking.htm>
2. <http://www.convert-me.com/en/convert/weight>
3. [http://wiki.answers.com/Q/Application\\_of\\_DC\\_series\\_generator](http://wiki.answers.com/Q/Application_of_DC_series_generator)
4. [http://www.dieselserviceandsupply.com/Parallel\\_Gensets.aspx](http://www.dieselserviceandsupply.com/Parallel_Gensets.aspx)

# Chapter 10

## Hybrid Vehicle Transmissions and Transaxles

### Chapter Summary

1. Manual transmissions are the simplest transmission design and use a driver-operated clutch mechanism to connect the ICE (Internal Combustion engine) to the transmission input shaft.
2. Torque converters can be described as infinitely variable transmissions that constantly adjust output speed and torque depending on vehicle operating conditions.
3. Hybrid electric vehicles (HEVs) with automatic transmissions use a modified torque converter lockup schedule to enhance regenerative braking.
4. Most automatic transmissions use planetary gearsets and hydraulically operated apply devices to achieve multiple gear ratios.
5. Automatic transmissions used in HEVs incorporate an electric auxiliary pump to provide transmission fluid pressure at engine idle stop.
6. Continuously variable transmissions (CVTs) utilize an infinite number of speed ratios to allow the ICE to operate in its most efficient RPM range during all phases of vehicle operation.
7. The two major types of CVTs include the belt-and-pulley system and the power-split system.
8. The power-split CVT utilizes two electric motor-generators and a planetary gearset to create infinite speed ratios.
9. The belt-and-pulley CVT uses a special steel belt and two variable-diameter pulleys to create infinite speed ratios.

### Key Terms

Belt-and-pulley CVT 154 • Bi-directional testing 141 • Brake 136 • Creep aid 155 • Differential 131 • eCVT 152 • Electric secondary fluid pump 140 • Energy recirculation 149 • Final drive 131 • FWD 131 • Gear ratio 133 • Generator motor 152 • Kinetic energy 149 • Motor/generator 152 • Nomograph 148 • Overdrive 134 • Overrunning clutch 136 • PCM 136 • Planetary gearset 136 • PTO 132 • Reduction 134 • RWD 131 • TCC 136 • TCM 136 • Torque 132 • Traction battery 153 • Traction motor 152



## Objectives

1. Describe the function of a vehicle's transmission. (Pages 131-132)
2. Understand the relationship required between the ICE and electric motor(s). (Page 141)
3. Describe how the idle stop function is related to the needs of the automatic transmission operation. (Page 144)
4. Discuss modifications made to automatic transmissions installed in hybrid electric vehicles (HEVs). (Page 144)
5. Explain the operation of continuously variable transmissions (CVTs). (Page 153)

## Lecture Resources:

### Search the Internet

1. Have the students research automotive careers that require the ability to repair, replace and troubleshoot clutches. Ask the students to prepare a report listing the career opportunities, their advantages and disadvantages, and their compensation levels. (Page 131)
2. Have the students research automotive careers that require the ability to repair, replace and troubleshoot transmissions. Ask the students to prepare a report listing the career opportunities, their advantages and disadvantages, and their compensation levels. (Page 132)
3. Have the students use the Internet to research the gear ratios in differentials of passenger vehicles. Also have them research the gear ratios in the differentials of high-performance drag race vehicles. Ask them to write a report comparing the gear ratios in the two types of vehicles. (Page 134)
4. Have the students use the Internet to research manufacturers of manual transmission fluid. Have them chart the advantages and disadvantages of each manufacturer and the price per quart for the fluid. Have the students determine the best buy for manual transmission fluid, based on their charts. (page 135)
5. Have the students use the Internet to research the evolution of the automatic transmission. Ask them to write a brief report that answers questions such as: How did early automatic transmissions shift? When were electronics first used in an automatic transmission and in what capacity? How many new transmissions

still use a valve body? Have students share their reports with the class. (Page 136)

6. Have the students use the Internet to research whether a hybrid vehicle uses a flywheel or flexplate similar to an ICE vehicle. Ask students to present their findings to the class. (Page 137)
7. Have the students use the Internet to find out whether upgraded bands and clutch disc are available for the transmission in a specific vehicle. What is the friction material made of in these parts as compared to stock parts? Have the students write a brief report of their findings. (Page 139)
8. Have the students use the schools electronic repair manual system to research the 4L60E transmission. Have the students note any safety or service differences between the conventional and hybrid 4L60E transmissions. Ask the students to share their findings with the class. (Page 140)
9. Have students use the Internet to research automatic transmissions that do not use planetary gears sets. Have the students prepare a report on their findings. Have the students share their finding with the class. (Page 141)
10. Have the students use the Internet to research when overdrive was first used in automatic transmissions. Have the students write a brief report about what model of transmission first used overdrive and what vehicle is was used in. Ask them to share their findings with the class. (Page 142)
11. Have the students use the Internet to research all of the Honda hybrids that use the hybrid transaxle. Ask students to share their findings with the class. (Page 146)
12. Have the students use the Internet to research transmissions that only use planetary gear sets, and no overrun clutched or one-way clutches. Have students prepare a report on their findings and share their findings with the class. (Page 148)
13. Have the students use the Internet to research how to drive a Toyota series-parallel hybrid electric vehicle. Have students prepare a report on their findings and share their findings with the class. (Page 149)
14. Have the students use the Internet to research Toyota series-parallel hybrid electric vehicle range before a charge is needed. Have students prepare a report on their findings and share their findings with the class. (Page 150)

15. Have the students use the Internet to research Toyota series-parallel hybrid electric vehicle energy recirculation. Have students prepare a report on their findings and share their findings with the class. (Page 151)
16. Using the school electronic repair information system have the students research safety precautions for working on the Toyota series-parallel hybrid electric vehicles. (Page 152)
17. Have the students use the Internet to find information on micro-hybrid-drive systems. How common is their use? What is the cost? Have students shared their findings in a class discussion. (Page 153)
18. Have the students use the Internet to research coolants and lubrications used in eCVT transmissions. Have students share their findings with the class. (Page 154)
19. Have students use the Internet and research CVT transmissions use in other vehicles. Have the students share their findings with the class. (Page 155)
20. Have the students use the Internet and research types of hill assist systems used in vehicles. Ask the students to share their findings with the class. (Page 156)
21. Have the students use the Internet to research automatic manual transmissions used on vehicles. Have the students share their findings with the class. Have them focus on heavy-duty hybrid vehicles. (Page 157)
22. Have the students use the schools electronic repair information system to look-up precautions for using a scan tool on a Honda CVT transmission. Also have the students research the available data list for this transmission and bi-directional control features available. (Page 158)

**Cross-Curriculum Activity: Mathematics-** Have the students use math to figure the ratio of several gear sets. Give them diagrams of a dozen gear reductions, overdrive gears, and idler sets. Have them figure the direction of rotation, ratio, and torque advantage of each set. (Page 133)

**ASSESS –** Have the students identify the parts of a planetary gear set. Grade them on their ability to correctly identify parts including the sun gear, the planetary carrier, and the ring (annulus) gear. (Page 138)

**Career Preparation-** Have the students research opportunities for transmission rebuilders. What electrical training is needed to be a transmission rebuilder? What types

of work are available? What is the salary range for transmission builders? Have students write a summary of their findings to share with the class. (Page 143)

**Cross-Curriculum Activity: Mathematics-**Have the students research the ratio of input and output created by the pulleys of a continuously variable transmission. What determines the ratio? What variables affect the ratio? Ask the students to summarize their findings to share with the class. (Page 144)

**Cross-Curriculum Activity: Mathematics-** Have the students use math to figure the ratio of several planetary gear sets. Give them diagrams of a dozen gear reductions, overdrive gears sets. Have them figure the direction of rotation, ratio, and torque advantage of each set. (Page 147)

**ASSESS –** Assign the students specific hybrid vehicle to research. Have the students research maintenance procedures and precautions for the assigned vehicles. Have the students create a presentation on the information to present to the class. Grade them on details and accuracy. (Page 155)

**ASSESS –** Have the students use the schools electronic repair information system to look-up the available data list for the Honda CVT transmission. Have them write a report on each of the inputs and outputs description of operation. Grade the students on detail and accuracy of the information. (Page 158)

### **Additional Topics:**

1. [http://en.wikipedia.org/wiki/Gear\\_ratio](http://en.wikipedia.org/wiki/Gear_ratio)
2. <http://www.californiajeep.com/crawl-ratio.htm>
3. <http://science.howstuffworks.com/transport/engines-equipment/diesel-locomotive.htm>
4. <http://www.essortment.com/diesel-electric-locomotive-engines-work-30125.html>

### **Discuss**

1. Ask students to discuss the experiences they may have had with clutches. (Page 131)
2. Ask the students to discuss how gear ratios help when pedaling a multi-speed bike. (page 132)

3. Ask the students to discuss the advantages and disadvantages of the transaxle design compared to the transmission design (Page 132)
4. Have the students discuss other places on the vehicle where leverage is used to reduce input effort. (Page 133)
5. **Hands-On-** Have the students use several combinations of fulcrums and levers to lift objects so they can experience the input force required to lift heavier objects or to move objects a longer distance. (Page 133)
6. Ask students to discuss the terms “gear reduction” and “overdrive.” In each combination, something is gained and something is lost. (For example, in gear reduction, the number of rotations is lost but torque is increased. (Page 134)
7. Ask the students to discuss the design of the ring and pinion that qualifies it as a hypoid gear assembly. (Page 134)
8. Have the students discuss the importance of using the proper fluid for each transmission they are working on. Have them discuss why different fluids are recommended for different transmissions. (Page 135)
9. Have the students talk about the purposes a torque converter plays in an automatic transmission. What is the reason for allowing slippage/ (Page 136)
10. Have the students talk about coupling between a fluid coupling and a mechanical coupling. (Page 136)
11. Have the students discuss how a torque converter drives the transmission oil pump. How does the inner portion of the front pump couple to the torque converter hub? (Page 137)
12. While showing the students examples of flexplates, discuss the external gear welded to the flexplate. What is the purpose of this gear? What will happen if the gear goes bad? (Page 137)
13. Have the students talk about the importance of operating a vehicle in the proper shift mode at the proper time. Which gears are used on gentle, long, or steep grades? (Page 138)
14. **SAFETY-** caution the students that parts on a planetary gear set can be very sharp and can cause personal injury. Also warn the students that planetary gear sets have many pinch points that can cause injury. (Page 138)
15. Have the students using figure 10-24 describe how a one-way clutch works. Ask the students if a sprag clutch works the same way? (Page 139)

16. Have the students discuss how a clutch pack applies and releases. What will happen if the clutch release too slowly? (Page 139)
17. **Hands-on-** Have the students raise a vehicle on a lift using proper safety procedures. Ask them to determine whether the bands can be adjusted with the transmission in the vehicle? (Page 139)
18. Have the students discuss the torque converter of the hybrid design 4L60E and the additional parts required. (Page 140)
19. **Hands-on-** Have the students use a scan tool to monitor critical TCC and electronic secondary fluid pump operation inputs. Have the students make notes of five key input values at idle. (Page 140)
20. **Hands-on-** Have the students use a scan tool to operate transmission solenoids and other transmission control circuits. Have the students make notes of five key Bi-Directional tests that can be performed. (Page 141)
21. Have the students talk about TAP and when a technician should reset transmission adaptive. What could be potential problems could arise from resetting TAP? (Page 141)
22. Have the students discuss a constant mesh automatic transmission and a conventional automatic transmission. (Page 141)
23. Have the students talk about figure 10-32 and compare this automatic transaxle with a manual transaxle (Page 142)
24. Have the students compare Figures 10-35 and 10-36 and talk about power flow difference in TCC in lockup and then release. What parts are used in both modes? (Page 143)
25. Have students talk about the importance of understanding power flow in an automatic transmission. How can power flow help to diagnose problems? (Page 143)
26. Have the students talk about the purpose and function of a continuously variable transmission. What are the advantages of a CVT? (Page 144)
27. Have the students talk about the operation of a continuously variable transmission. What is the difference in the pulleys? (Page 144)
28. Have the students discuss the diagnostic capabilities of a Honda automatic hybrid transaxle. In clued inputs and outputs. (Page 146)

29. **Hands-on-** Have the students use a scan tool to view inputs and outputs of the Honda hybrid automatic transaxle. Have the students make notes of five key inputs and outputs that can be viewed on the scan tool.(Page 146)
30. Have the students talk about how the power-split device works in a series-parallel hybrid works. What is the power split? (Page 147)
31. Environment- Are there better ways to create the electricity required to charge hybrid electric vehicles without using standard power plants? Most power plants create harmful emissions, so using this supply of electricity may reduce or negate the purpose of using hybrid electric vehicles. Ask the students to share their thoughts on this issue. (Page 147)
32. Have students discuss the advantages and disadvantages of series-parallel hybrid electric technology. Why is it called a strong hybrid? (Page 147)
33. Have students compare figure 10-44 and 10-45, what is different for each condition? Where does the energy come from to keep the radio and other accessories operating while the engine is off? (Page 148)
34. Talk about how an Ice engine starts in the Toyota series-parallel hybrid technology after stopping. (Page 148)
35. Review idle stop mode with the students and highlight the difference between a vehicle equipped with idle stop and vehicle not equipped. What could be the fuel and emissions impact on the environment? (Page 149)
36. Have students discuss how acceleration is accomplished on a Toyota series-parallel hybrid system. Talk about the advantages and disadvantages to this type of technology. (Page 150)
37. Review regenerative braking and how this technology accomplishes charging the HV battery. (Page 150)
38. Have students discuss the advantages and disadvantages of one motor acting as a generator to supply energy to power the other motor (Page 151)
39. **SAFETY-** Review with students the importance of following manufacturers' safety recommendation when working on hybrid electric vehicles. (Page 152)
40. Using figures 10-57, 10-58, and 10-59 have students talk about the information in each figure. Ask students to discuss the service procedures for a conventional transaxle compared to a hybrid transaxle. (Page 153)

41. Have the students discuss other vehicle systems that use splash lubrication techniques for lubrications and cooling. Discuss the advantages and disadvantages of this type of lubrication system. (Page 154)
42. Have the students compare the Honda series-parallel system to the eCVT system Ford designed. What are the similarities and differences of each system? (Page 154)
43. Have the students talk about the operation of eCVT transmission. Have them research the fuel economy rating for this type of hybrid electric vehicle and discuss the results. What type of hybrid is the Escape? Mild-medium, or Full hybrid? (page 154)
44. Review with the students driven and drive relationships when calculating gear ratios. Have the students discuss the importance of understanding what member is drive, and what member is driven. What are parasitic losses?(Page 155)
45. Have the students discuss a dual-mass flywheel. What are the characteristics of a dual-mass flywheel? What are the benefits? (Page 156)
46. Have students discuss the “creep aid” function of the Honda belt-and-pulley CVT transmission. What are the advantages and disadvantages? (page 156)
47. Ask students to discuss the type of transmission fluid required by the Honda CVT transmission. Have them compare the service and fluid requirements of the Ford eCVT and the Honda CVT. (Page 158)
48. Have students talk about the different engine controls and transmission controls used to computer control a Honda CVT transmission. (Page 158)

## **Demonstrate**

1. Show students examples of a clutch disc, throw-out bearing and pressure plate. (page 131)
2. Show the students how a fulcrum and lever can reduce lifting effort. Set a long lever on the fulcrum one-quarter of the way to the load you want to lift. Then move the fulcrum to one-quarter of the distance from the input point. Show the students how decreasing lift effort increases the length of movement and then the opposite happens for the other setup. (Page 133)
3. Show the students how to check manual transmission level. Drain and fill a manual transmission. (Page 135)



4. Using a converter that has been cut open, show the students the various parts inside a torque converter, including the impeller, turbine, stator, one-way clutch, and converter clutch (if present). (Page 136)
5. To demonstrate how the fluid coupling in a converter works, use two fans facing each other. Turn one fan on and have the students observe the other fan's blades turning. (Page 137)
6. Show the students a planetary gear set from an automatic transmission. Identify the parts including the sun gear, the planetary carrier, and the ring (annulus) gear. (Page 138)
7. Show the students a disassembled clutch pack and identify a friction plate and steel plate. (Page 139)
8. Show the students a starter-generator stator assembly, rotor assembly and unique flexplate. Point out the safety precautions while handling these parts. (Page 140)
9. Show the students a Honda constant mesh automatic transmission. Show the students the students the four parallel shafts and name them. (Page 141)
10. Using a hybrid and a conventional vehicle measure exhaust pollution at idle and compare the two. Ask students to discuss the environmental benefits if vehicles producing less CO<sub>2</sub>. (Page 149)
11. Show students the coolant, and transaxle drain plugs for service. Include showing the students where the refill points are in each system. (Page 152)
12. Show the students how to properly hoist a hybrid escape vehicle. Point out the electronic control unit, coolant tubes for cooling electronic controls and ATF. (Page 154)
13. Show the students using a multi gear bicycle the concepts on driven and drive. Have the students calculate the different gear ratios for the bicycle. (page 155)
14. Show the students the operation of the Honda CVT start clutch. )Page 157)
15. Using a scan tool have the students observe CVT transmission operation through the various scan tool data. Have the students make files of the CVT transmission activities. (Page 157)
16. Show the students how to perform a starter clutch calibration on a Honda hybrid CVT transmission using a scan tool. (Page 158)

17. Show students how to properly check the transmission fluid on a Honda Hybrid CVT transmission. (Page 158)

## **Student Activities**

1. MAL chapter 121 Power Point (Page 131)
2. MAL Chapter 122 Power Point (Page 133)
3. MAL Chapter 121.1 Activity Clutch Labeling (page 134)
4. MAL Chapter 125 Power Point (Page 134)
5. MAL Chapter 125.2 Activity Calculating the rear axle ratio (Page 134)
6. MAL Chapter 122.3 Activity 5-speed manual transmission labeling (Page 134)
7. MAL Chapter 122.3 Activity Shift mechanism labeling (Page 134)
8. MAL Chapter 122.3 Activity Synchronizer Assembly labeling (Page 134)
9. MAL Chapter 122.3 Animation Synchronizer operation (Page 134)
10. MAL Chapter 122 All diagnostic assessments under shop
11. MAL Chapter 122 NATEF Job Sheet Diagnose Fluid Loss (Page 203)
12. MAL Chapter 122 NATEF Job Sheet drain and fill manual transaxle (Page 158)
13. MAL Chapter 122 NATEF Job Sheet manual transaxle fault diagnosis (Page 158)
14. MAL chapter 122 NATEF Job Sheet Synchronizer Assembly (Page 134)
15. MAL Chapter 122 NATEF Job Sheet Electronic Control manual Transmission (Page 158)
16. MAL Chapter 127 Power Point Chapter 127 (Page 136)
17. MAL Chapter 128 Power Point 128 (Page 138)
18. MAL Chapter 127.1 Activity Torque Converter labeling 1 (Page 136)
19. MAL Chapter 127.1 Activity Torque Converter Labeling 2 (Page 137)

20. MAL Chapter 127.2 Activity Planetary Gear set labeling (Page 138)
21. MAL Chapter 128.1 Activity Hydraulic Components and control Systems Labeling (Page 139)
22. MAL Chapter 128.4 Activity Label one-way-clutches (Page 139)
23. MAL Chapter 128.5 Animation one-way-clutch operation Page 139)
24. MAL Chapter 128.3 Activity Multi-disc clutch labeling (Page 139)
25. MAL Chapter 128.4 Animation Clutch Pack Operation (Page 139)
26. MAL Chapter 128.8 Activity label the power flow through an automatic transmission (Page 140)
27. MAL Chapter 128 Animation CVT Basics (Page 144)
28. MAL Chapter 128 NATEF Job Sheet Automatic Transmission/Transaxle ID
29. MAL Chapter 127 NATEF Job Sheet diagnose Fluid Loss
30. MAL Chapter 128 NATEF Electronic transmission scan tool diagnosis (Page 158)
31. MAL chapter 128 Diagnostic assessments under shop all
32. MAI Chapter 129 Power Point
33. MAL Chapter 130 Power point

## **Review Questions / Answers**

1. What is the difference between torque and horsepower? (Text page 133)  
**Torque is twisting force. For instance, engine torque is the twisting force that is developed at the crankshaft when the engine is running. Horsepower is the rate at which work is done, and is a function of torque and engine RPM.**
  
2. What are the three elements in a torque converter, and how is torque increased during vortex flow? (Text page 135)  
**The three elements in a torque converter are the pump (impeller), the turbine, and the stator.**  
**During vortex flow, the pump is turning faster than the turbine. The pump sends fluid into the turbine, and the fluid flows through the turbine assembly and then enters the stator. The stator**

assembly redirects the fluid flow into the pump inlet in such a way that the pump is “supercharged” and torque is thus increased across the torque converter assembly. During vortex flow, the stator assembly is locked on its one-way clutch and remains stationary.

3. What are the differences in the operation of an automatic transmission that has been modified for use in a hybrid electric vehicle? (Text pages 138-140)  
**An automatic transmission in a hybrid-electric vehicle will have two primary modifications. First, an electric auxiliary pump will be installed that maintains transmission line pressure during idle stop mode. Second, the transmission will prevent “coasting” during slowdown and braking and will allow torque to be transmitted from the drive wheels to the ICE to enable regenerative braking.**
  
4. Why does a CVT maximize the efficiency of an internal combustion engine? (Text page 153)  
**A continuously variable transmission (CVT) maximizes the efficiency of an ICE by constantly varying its gear ratio so that the ICE can run in its most efficient RPM range for all vehicle speeds.**

#### CHAPTER QUIZ QUESTIONS AND ANSWERS:

1. A 5-speed manual transaxle has a fifth-gear ratio of 0.95:1. Technician A says that the transaxle output speed will be greater than the input speed in fifth gear. Technician B says that fifth gear is an overdrive gear ratio. Which technician is correct? (Text page 134)
  - a. Technician A only
  - b. Technician B only
  - c. **Both Technician A and B**     x
  - d. Neither Technician A nor B
  
2. In a GM two-mode hybrid electric vehicle, when can the vehicle be powered by electric power alone? (Text page 141)
  - a. **During the first mode**     X
  - b. During the second mode
  - c. During either the first or second mode
  - d. During heavy load conditions regardless of mode

3. The period of torque converter operation where the turbine is turning at 90% of the impeller (pump) speed is known as \_\_\_\_\_. (Text page 136)

- a. **Coupling phase X**
- b. Vortex flow
- c. Torque converter lockup
- d. Torque multiplication

4. Technician A says that a torque converter clutch reduces slippage. Technician B says that an auxiliary fluid pump is needed for the transmission to function during idle stop mode. Which technician is correct? (Text pages

136; 140)

- a. Technician A only
- b. Technician B only
- c. **Both technicians A and B X**
- d. Neither technician A nor B

5. Modifications to automatic transmissions used in hybrid vehicles include \_\_\_\_\_. (Text pages 138-140)

- a. Electric auxiliary transmission fluid pumps
- b. Modified torque converter lockup schedule
- c. Increased number of plates in multiple-disc clutches
- d. **Both A and B are correct X**

6. Technician A says that power-split CVTs use a torque converter. Technician B says that power split CVTs use an electric transmission fluid pump. Which technician is correct? (Text page 145)

- a. Technician A only
- b. Technician B only
- c. Both Technicians A and B
- d. **Neither Technician A nor B X**

7. All of the following statements concerning power-split CVTs are true, *except* \_\_\_\_\_. (Text page 146)
- a. The ICE and motor-generators are all connected through a planetary gearset
  - b. One of the planetary members must be held to make the power-split CVT work x**
  - c. The power-split CVT can operate in electric mode only
  - d. Power-split CVT systems do not use a separate starter motor
8. The Honda CVT is connected to the ICE with a \_\_\_\_\_. (Text page 154)
- a. Torque converter
  - b. Manually operated clutch mechanism
  - c. Drive plate and flywheel X**
  - d. None of the above
9. In a Toyota/Lexus hybrid electric vehicle, how is reverse achieved? (Text page 150)
- a. The ICE reverses direction and powers the drive wheels.
  - b. MG2 is used to power the vehicle in reverse X**
  - c. MG1 is used to power the vehicle in reverse
  - d. Either b or c depending on exact model and year
10. Technician A says that all automatic transmissions use planetary gearsets. Technician B says that all CVTs use torque converters. Which technician is correct? (Text pages 139; 156-157)
- a. Technician A only
  - b. Technician B only
  - c. Both Technicians A and B
  - d. Neither Technician A nor B X**

## ASE / NATEF Correlation Charts

1.

**Suggestions for related instruction (web links / books / movies / etc.)**

1. <http://www.fireblades.org/forums/aprilia-motorcycles/51941-aprilia-mana-cvt-transmission.html>
2. [http://www.bgprod.com/news/cvt\\_fluid.html](http://www.bgprod.com/news/cvt_fluid.html)
3. <http://www.world.honda.com/automobile-technology/CVT/>
4. [http://en.wikipedia.org/wiki/Continuously\\_variable\\_transmission](http://en.wikipedia.org/wiki/Continuously_variable_transmission)

# Chapter 11

## Hybrid Vehicle Heating and Air Conditioning

### Chapter Summary

1. The purpose of the ICE cooling system is to bring the ICE to optimum temperature as quickly as possible and to maintain that temperature under all operating conditions.
2. A thermostat is used to maintain the optimum coolant temperature in the ICE cooling system.
3. OAT (organic acid technology) and HOAT (hybrid organic acid technology) are two types of coolant being used in newer vehicles.
4. Electric helper pumps are used to circulate coolant in the heating system when an HEV enters idle stop mode.
5. The coolant heat storage system is used to limit vehicle emissions during cold starts.
6. The electric motor and motor electronics on a hybrid electric vehicle will often have their own liquid-cooling system.
7. Most HEVs use scroll compressors in their air-conditioning systems.
8. Some HEVs use A/C compressors with electric drive or a combination belt-electric drive mechanism.
9. Nonconductive refrigeration oil is used in A/C compressors with electric drives.
10. PCT heaters are used to provide supplemental heat in HEV heating systems.

### Key Terms

Accumulator 180 • Antifreeze 162 • Barrier hose 184 • Blend door 172 • Blower motor 177 • Bypass tube 161 • Cabin filter 177 • Change of state 175 • Compressor 175 • Condenser 175 • Coolant heat storage system 168 • Coolant recovery reservoir 165 • Crossflow 166 • Downflow 166 • Ethylene glycol 162 • Evaporator 175 • Evaporator drain 182 • Fan clutch 167 • Heat exchanger 165 • Heater core 161 • Helper pump 163 • HOAT 162 • Hygroscopic 179 • IAT 162 • Impeller 162 • Low-grade heat 168 • OAT 162 • OT 180 • PAG 179 • Phase-change liquid 175 • Plenum chamber 172 • Pressure cap 164 • Pressure drop 176 • PTC 172 • PTC heater 172 • R-134a 175 • Radiator 160



• Radiator hose 168 • Receiver-drier 180 • Refrigerant 175 • Scroll compressor 177 • Surge tank 165 • Thermoelectric switch 167 • Thermostat 161 • TXV 180 • Water jacket 160 • Water pump 160 • Water valve 169 • Zone valve 182

## Objectives

1. Explain the operation of the ICE cooling system. (Page 160)
2. Explain the operation of the motor/electronics cooling system in a hybrid electric vehicle. (Page 173)
3. Explain the operation of a coolant heat storage system. (Page 168)
4. Describe the function of a vehicle's heating and A/C system. (Page 175)
5. Discuss the operation and unique service procedures for electric-drive A/C compressors. (Page 177)

## Lecture Resources:

### Search the Internet

1. Have students research how many PCM codes and bulletins are related to engine overheating. Ask them to share their findings in class. (Page 160)
2. Have students research and compare older cooling systems and newer cooling systems. Have them discuss their findings in class. (Page 161)
3. Have students research which coolants are organic acid technology types besides DEX-COOL, Have them discuss their findings in class. (Page 162)
4. Have students research the difference between positive displacement pumps and centrifugal pumps. Have them relate their findings in class. (Page 163)
5. Have students research pressure cap locations other than the top of the radiator. Ask them to share their findings in class. (Page 165)
6. Have students use the Internet to research the 14 rules for improving engine coolant systems  
([http://www.arrowheadradiator.com/14\\_rules\\_for\\_improving\\_engine\\_cooling\\_system\\_capability\\_in\\_high-performance\\_automobiles.htm](http://www.arrowheadradiator.com/14_rules_for_improving_engine_cooling_system_capability_in_high-performance_automobiles.htm)) (Page 167)
7. Have students research what PCM codes would turn on the electric cooling fan. (Page 168)

8. Have students research the used coolant disposal laws in the area. Discuss their findings in class. (Page 169)
9. Have the students research the use of coolant storage tanks in other vehicles or applications. Have students discuss their findings in class. (Page 170)
10. Have the students research the Internet for the first types of heaters used in automobiles. Ask the students to share their findings with the class. (Page 172)
11. Have the students research the Internet for other types of automotive electric coolant heater used on automobiles and trucks. Ask the students to share their findings with the class. (Page 174)
12. Have the students research the Internet for how to select a heat sink for electronics. Ask the students to share their findings in class. (Page 175)
13. Have the students research the Internet for liquid coolers used in the automotive industry. (Page 176)
14. Have students use the Internet to research the principles of latent heat. Ask them to write a short description of how this principle relates to a car's (page 177)
15. Have students use the Internet to research the history of automotive air-conditioning systems. Ask them to write a short description of their origin and evolution. (page 180)
16. Many automotive air-conditioning systems today offer features such as thermostatic controls and individualized passenger settings. Have students use the Internet to research how these features work. Ask students to pick a specific feature and write a description of how it works. (Page 182)

**ASSESS-** Have students replace a thermostat. Grade them on their ability to complete the task and follow safety procedures. (Page 164)

**Cross-Curricular Activity: Physics-** Have students write a paper about expansion and contraction of a liquid as it heats and cools. Have them explain how this expansion and contraction is controlled in the cooling system. (For example, where does the expanded coolant go and how does it get back into the radiator? (Page 165)

**ASSESS-** Have students drain, remove, install, and refill a radiator. Grade them on their ability to complete the task and follow safety procedures. (Page 166)

**ASSESS-** Have students identify the parts of the coolant system on a Prius. Grade them on their ability to follow safety procedures and accurately identifying the parts. (Page 171)

**Cross-Curricular Activity: Physics-** Have students research on the states of matter. Through the most common state of matter are solids, liquids, and gas, ask them to explore at least three other possible states. Ask students to share their findings with the class. (Page 173)

**ASSESS-** have student write a paper on how hybrid air-conditioning systems work. Grade students on the completeness and accuracy of their work (Page 178)

**Cross-Curricular Activity: English-** have students write a description of how a cold evaporator attracts the heat from inside the vehicle to help lower the temperature for passengers. Ask students to focus on adjectives in their description, using at least five different adjectives. (Page 179)

**Cross-Curricular Activity: Electricity and Electronics-** Have students write a paper that discusses the electrical systems and components used to power and control today's automotive air-conditioning systems. (Page 181)

**Cross-Curricular Activity: Engineering-** Have students write a paper comparing expansion valve automotive air-conditioning systems to orifice tube systems. Have students indicate which type of system they think is preferable. Ask students to read their paper in class and defend their position. (Page 183)

**ASSESS-** have students research the phenomenon of superheat. Ask them to write a brief paper on superheat, including how to measure it and how it relates to the vaporization of refrigerant before it leaves the evaporator. Grade students for the accuracy and completeness of their work. (Page 184)

#### **Additional Topics:**

1. [http://www.arfc.org/complaints/2008/ford/escape\\_hybrid/engine\\_and\\_engine\\_cooling/problem.aspx](http://www.arfc.org/complaints/2008/ford/escape_hybrid/engine_and_engine_cooling/problem.aspx)
2. <http://www.aboutautomobile.com/Complaint/2007/Toyota/Camry+Hybrid/Engine+and+Engine+Cooling+System>
3. <http://www.howstuffworks.com/cooling-system.htm>
4. <http://www.hybrex.org/>
5. <http://auto.howstuffworks.com/cooling-system10.htm>
6. <http://blog.yagelski.com/2011/02/ford-escape-hybrid-electric-motor.html>
7. <http://hybridreview.blogspot.com/2006/07/hybrid-car-air-conditioning.html>

## Discuss

1. Have students discuss the heat generated in an engine. Ask them, “if one-third of the heat is removed through the cooling system, and one-third is removed through the exhaust system, what is the other one-third used for?” (answer: Pushing pistons down) (Page 160)
2. **TIP-** Engines that do not reach proper operating temperature may leave water in the oil, which can cause engine failure, such as bearing failure. (page 160)
3. Discuss with students how improper coolant temperature can harm fuel economy. (Page 160)
4. **TIP-** The check engine light can come on with codes for high coolant temperature. Just as it does for low coolant temperature. (Page 161)
5. Have students discuss possible reasons that older engines were less likely to have engine failure from overheating. (The reason is that the heavy steel blocks and heads displaced heat better and were able to take higher temperatures without damage due to the amount of metal.) (Page 161)
6. **Review-** Review how the cooling system is similar to the air conditioning system. (Page 161)
7. **Environment-** Coolant should not be poured into the sewer system. Even if the coolant does not harm anything, the metals removed from the automobile will not break down. (Page 162)
8. Discuss how mixing of types of coolants may harm the system. (Page 162)
9. **SAFETY-** Explain that coolant spills should be cleaned up immediately since they are very slick. (Page 162)
10. Discuss with students the water pump operation. (Page 163)
11. **TIP-** When checking a thermostat for an overheating condition, be sure the thermostat is installed correctly. (Page 164)
12. Discuss with students the methods of testing thermostats and the positive and negatives of each. (Page 164)
13. **TIP –** Overheating transmissions can cause engine overheating issues. (Page 165)

14. **SAFETY-** Always remove a pressure cap slowly using rags for protection. A hot cooling system can spray coolant or steam under pressure. Even a cold system may have pressure that can spray coolant into the eyes or mar the paint. (Page 165)
15. Discuss with students why the recovery bottle is important to the longevity of the cooling system's effectiveness. (Page 165)
16. Discuss the importance of heat transfer. (Page 166)
17. **TIP-** Older steel radiators could often be repaired. Most of the newer radiators cannot be repaired, due to cost, and must be replaced if faulty. (Page 166)
18. Discuss with students the difference in coolant flow systems. (Page 167)
19. **SAFETY-** Electric coolant fans can come on unexpectedly. Always keep hands and objects clear of them (Page 168)
20. **TIP-** Spring-type fans should spin freely on a cold engine. (Page 168)
21. **TIP-** When checking radiator hoses, remember that the bottom hose may have a spring inside to keep it from collapsing. (Page 169)
22. Discuss with students the need for a coolant storage tank in a hybrid vehicle (Page 170)
23. Using the school information system ask students look up the operation of the coolant heat storage system on Toyota Prius 2004-2009. Ask students to make a list of inputs and outputs used in the system. (Page 170)
24. Have the students discuss the four modes of operation of a coolant heat storage system. (Page 171)
25. Discuss the two modes of operation in figure 11-26 and 11-27 (Page 172)
26. Ask students to discuss the three states of water and how they relate to automotive heating and air-conditioning system. Explain how the molecules of water are moving at the different states. Ask why there has to be an unbalanced force for the molecules to transfer heat. (Page 173)
27. Ask students to discuss the relationship between pressure and temperature in a cooling system (Page 175)
28. **TIP-** Some DVOMs come with a temperature probe for checking temperatures. Use this on coolant hoses to check temperatures. Also infrared temperature guns are available to check temperature. (Page 175)

29. Discuss with the students how a multi-speed coolant fan works. (Page 176)
30. Ask students to talk about how heat is absorbed by an automotive air-conditioning system. (Page 177)
31. Ask students to talk about the types of refrigerants that have been used in automotive systems and in residential home AC systems. Why is CFC-12 no longer used? (Page 179)
32. **TIP-** Residential home refrigerants can't be used in automotive systems. (Page 179)
33. Ask students to discuss the purpose and function of an air-conditioning compressor (Page 180)
34. **Review-** Students studied Ohm's law when learning about electrical and electronic systems. (Page 181)
35. Ask students to discuss the AC system oil requirements for a hybrid versus a typical AC system. (Page 182)
36. Ask students to discuss hygroscopic and name some other automotive fluids that are hygroscopic. (Page 182)
37. Ask students to discuss how an evaporator helps remove moisture from the air and lower humidity. (Page 183)
38. Ask students to talk about the role of the desiccant in the drier. What would happen if it were omitted? (page 183)
39. Ask students to talk about how the sensing bulb, capillary tube, and diaphragm inside the expansion valve work together to regulate the flow of refrigerant into the evaporator. (Page 183)
40. Ask students to discuss how an orifice tube separates the high-pressure and low-pressure sides of the air-conditioning system. How does this method differ from the one used in an expansion valve system? (Page 184)
41. Ask students to discuss how refrigerant lines and hoses differ from radiator cooling system hoses. (Page 184)

## **Demonstrate**

1. Show students examples of coolant colors. (Page 162)
2. Show students different variations of a water pump. (Page 163)

3. Show students electric helper coolant system pumps. (Page 163)
4. Using the hot water method, show how a thermostat opens and closes. (Page 164)
5. Demonstrate how a pressure cap vents at the pressure listed. (Page 165)
6. Show students different types of coolant recovery bottles. (Page 165)
7. Show students different styles of radiators. (Page 166)
8. Show students different head gasket designs and coolant passages through them. (Page 167)
9. Show students how a fan shroud helps direct airflow through the radiator. (Page 168)
10. Show students a Toyota Coolant heat storage system in a Toyota Prius or the parts of a coolant storage system. (Page 169)
11. Using a scan tool have students customize a PID list that focuses on the coolant system. Have students discuss each PID and what information it is supplying to the computer for operation. (Page 170)
12. Show the students a Prius operating in each mode using a scan tool to monitor the systems activities through computer data. (page 171)
13. Show students the difference in temperature between coolant tank outlet temperature sensor and engine coolant temperature sensor. Discuss the difference. (Page 172)
14. Using a meter show students the difference between a positive coefficient and a negative coefficient conductor. Discuss with the students the difference between the two. (Page 173)
15. Using a plenum chamber from a vehicle show the students how a plenum chamber works in a typical vehicle. (Page 174)
16. Using a scan tool show the students how to operate the blower motor and plenum chamber doors. (Page 174)
17. Using a scan tool access the electronics cooling fan and operate the fan from the scan tool. Discuss the bi-directional control that most vehicle and scan tools feature for diagnostic assistance. (Page 176)

18. Borrow either a hydrometer or a Psychrometer from your school's science lab, and show students how they are used to measure relative humidity. (Page 177)
19. Show the students the parts of an automotive cooling system. Point out the compressor and explain how it works. (Page 178)
20. Using a scan tool show students all of the data available to diagnose a hybrid air-conditioning system. Show students any bi-directional control available. (Page 179)
21. Show students an example of a scroll compressor and how it works. (Page 180)
22. Ask students to talk about how an electromagnetic clutch works to control the compressor (Page 181)
23. Show students hybrid AC system PAG oils. (Page 182)
24. Show students the condenser on an automotive air-conditioning system. Describe its purpose and how it works (Page 183)
25. Show students the receiver-dryer in an automotive air-conditioning system and describe its purpose and function. (page 184)

## **Student Activities**

1. MAL Chapter 20 Power Point (page 163)
2. MAL Chapter 21 Power Point (Page 160)
3. MAL Chapter 20.1 Activity Cooling system labeling (Page 161)
4. MAL Chapter 20.1 Crossword Coolant (Page 162)
5. MAL Chapter 21.3 Animation Pressure cap operation (Page 163)
6. MAL Chapter 21.1 Animation Thermostat operation (Page 164)
7. MAL Chapter 17 NATEF Task Sheet Coolant System Inspection
8. MAL Chapter 17 NATEF Task Sheet Testing and replacing coolant
9. MAL Chapter 17 NATEF Task Sheet Coolant System Inspection
10. MAL Chapter 17 NATEF Task Sheet Coolant Flush
11. MAL Chapter 17 NATEF Task Sheet Coolant System Test



12. MAL Chapter 17 NATEF Task Sheet Engine coolant fan Inspection
13. MAL Chapter 17 NATEF Task Sheet Identify the cause of engine  
overheat
14. MAL Chapter 62 Power point
15. MAL Chapter 63 Power point
16. MAL Chapter 64 Power point
17. MAL Chapter 65 Power point
18. MAL Chapter 62.1 Activity Air-Conditioning components part 1  
labeling
19. MAL Chapter 62.1 Activity Air-Conditioning components part 2  
labeling
20. MAL Chapter 62.1 Activity Air-Conditioning components part 3  
labeling
21. MAL Chapter 62.3 Animation Expansion valve
22. MAL Chapter 10 Shop Assessment My AC is not cooling properly

## Review Questions / Answers

1. What is the difference between torque and horsepower? (Text page 133)
  - a. **Torque is twisting force. For instance, engine torque is the twisting force that is developed at the crankshaft when the engine is running. Horsepower is the rate at which work is done, and is a function of torque and engine RPM.**
  
2. What are the three elements in a torque converter, and how is torque increased during vortex flow? (Text page 135)
  - a. **The three elements in a torque converter are the pump (impeller), the turbine, and the stator.**
  - b. **During vortex flow, the pump is turning faster than the turbine. The pump sends fluid into the**
  - c. **turbine, and the fluid flows through the turbine assembly and then enters the stator. The stator**
  - d. **assembly redirects the fluid flow into the pump inlet in such a way that the pump is "supercharged"**

- e. **and torque is thus increased across the torque converter assembly. During vortex flow, the stator**
  - f. **assembly is locked on its one-way clutch and remains stationary.**
3. What are the differences in the operation of an automatic transmission that has been modified for use in a hybrid electric vehicle? (Text pages 138-140)
- a. **An automatic transmission in a hybrid-electric vehicle will have two primary modifications. First, an**
  - b. **electric auxiliary pump will be installed that maintains transmission line pressure during idle stop**
  - c. **mode. Second, the transmission will prevent “coasting” during slowdown and braking and will allow**
  - d. **torque to be transmitted from the drive wheels to the ICE to enable regenerative braking.**
4. Why does a CVT maximize the efficiency of an internal combustion engine? (Text page 153)
- a. **A continuously variable transmission (CVT) maximizes the efficiency of an ICE by constantly**
  - b. **varying its gear ratio so that the ICE can run in its most efficient RPM range for all vehicle speeds.**

#### CHAPTER QUIZ QUESTIONS AND ANSWERS:

1. What is the operation of the coolant heat storage system? (Text page 168)  
**The coolant heat storage system is used in the 2<sup>nd</sup> generation Toyota Prius to enable quicker starts and reduce cold-start emissions. When the ICE is at operating temperature, hot coolant is stored in a storage tank that is constructed similar to a Thermos<sup>®</sup> bottle. This coolant is then used to warm the cylinder head of the ICE prior to a cold start.**
2. What is the difference between IAT and OAT/HOAT coolants? (Text page 162)  
**IAT (inorganic additive technology) coolants use silicates for corrosion inhibitors. The abrasive nature of silicates and the relatively short service life of IAT coolants prompted automobile manufacturers to develop corrosion inhibitor packages that reduced or eliminated silicates. OAT**

**(organic acid technology) and HOAT (hybrid organic acid technology) are examples of corrosion inhibitors that are used in today's extended-life coolants.**

3. Why is the motor-electronics cooling system separate from that of the ICE? (Text page 173)  
**The motor-electronics cooling system is separate from the ICE cooling system because electronic components tend to operate more efficiently at lower temperatures. While the ICE should be operated at close to 200 degree F at all times, electronic components should be kept cooler than this and thus must use a separate cooling system.**
  
4. What is the function of a PTC heater, and why is it used in an HEV heating system? (Text page 172)  
**A PTC (positive temperature coefficient) heater is an electric-powered heater that uses a resistance element. In hybrid-electric vehicles, a PTC heater can be used to boost cabin heat when the ICE operating temperature is low. This can be accomplished through use of a heating element located in the vehicle's heater core, or with heating grids in the air ducting.**

#### **CHAPTER QUIZ QUESTIONS AND ANSWERS:**

1. Coolant circulates through all of the following when the thermostat is closed, *except* \_\_\_\_\_ . (Text page 161)
  - a. Heater core
  - b. Radiator X**
  - c. Water jacket
  - d. Cylinder head
  
2. Technician A says that OAT coolants are based on propylene glycol. Technician B says that HOAT stands for hybrid organic acid technology. Which technician is correct? (Text page 162)
  - a. Technician A only
  - b. Technician B only X**
  - c. Both Technicians A and B
  - d. Neither Technician A nor B

3. All of the following are examples of heat exchangers, *except* \_\_\_\_\_. (Text page 165)
- a. Condenser
  - b. Heater core
  - c. Evaporator
  - d. **Thermostat X**
4. A coolant heat storage tank can keep coolant warm for a maximum of \_\_\_\_\_ day(s). (Text page 168)
- a. One-half
  - b. Two
  - c. **Three X**
  - d. Four
5. The coolant heat storage system is being discussed. Technician A says that the water valve is driven by an electric motor. Technician B says that the storage tank has its own electric water pump. Which technician is correct? (Text pages 169-170)
- a. Technician A only
  - b. Technician B only
  - c. **Both Technicians A and B X**
  - d. Neither Technician A nor B
6. All of the air entering the passenger compartment must pass through the \_\_\_\_\_. (Text page 172)
- a. **Evaporator X**
  - b. Condenser
  - c. Heater core
  - d. Radiator
7. Scan data indicates that the starter generator control module (SGCM) on a GM hybrid pickup has overheated. The *least likely* cause would be \_\_\_\_\_. (Text page 174)
- a. Low coolant level
  - b. **Stuck thermostat X**
  - c. Inoperative fan
  - d. Faulty electric pump
8. Technician A says that PTC heaters can be built into a conventional heater core assembly. Technician B says that a PTC heater's electrical resistance will decrease as its temperature increases. Which technician is correct? (Text page 172)
- a. **Technician A only X**

- b. Technician B only
- c. Both Technicians A and B
- d. Neither Technician A nor B

9. All of the following statements about hybrid electric vehicle A/C compressors are true, *except*

\_\_\_\_\_.

(Text page 177)

- a. **Most are reciprocating piston designs X**
- b. Some use a belt drive along with an electric motor
- c. Some use only an electric motor without a belt drive
- d. Nonconductive refrigeration oil must be used with A/C compressors utilizing an electric drive motor

10. A device used to turn refrigerant flow on and off in an air-conditioning system with multiple evaporators is

called a \_\_\_\_\_. (Text page 182)

- a. Refrigeration switch
- b. Flow valve
- c. Zone control
- d. **Zone valve X**

## ASE / NATEF Correlation Charts

1.

### Suggestions for related instruction (web links / books / movies / etc.)

1. [http://www.ehow.com/how\\_2106\\_diagnose-cooling-system.html](http://www.ehow.com/how_2106_diagnose-cooling-system.html)
2. [http://www.youtube.com/watch?v=le\\_dVNhpT14](http://www.youtube.com/watch?v=le_dVNhpT14)
3. <http://www.youtube.com/watch?v=iXRJ4il4U0c>
4. [http://www.youtube.com/watch?v=xTI\\_y9-1QTA](http://www.youtube.com/watch?v=xTI_y9-1QTA)

# Chapter 12

## Honda Hybrid Vehicles

### Chapter Summary

1. The first production hybrid electric vehicle sold in the United States was the Honda Insight.
2. The Honda Insight used a three-cylinder gasoline engine and Integrated Motor Assist (IMA) system to provide for idle stop, regenerative braking, and power assist during acceleration.
3. The Honda Civic hybrid is based on the conventional gasoline model and provides improved fuel economy and power.
4. The i-VTEC system closes both the intake and exhaust valves of all four cylinders of a four-cylinder Civic hybrid (2006+) and three cylinders on the V6 Accord hybrid during deceleration to increase the amount of kinetic energy captured by the regenerative braking.
5. The batteries used in Honda hybrids are D-cell-size NiMHs connected in series to produce 144 volts.
6. The Honda Accord hybrid provides rapid acceleration and uses active engine mounts and active noise control to counter engine noise created during cylinder deactivation.
7. Honda hybrid engines use a linear air–fuel (LAF) sensor for fuel control.
8. The IMA battery module and the electronic modules are located behind the rear seat and are air-cooled.
9. Except for depowering the high-voltage system and some unique spark plugs used on the Insight, most service procedures are the same as for conventional vehicles.

### Key Terms

ANC 187 • Battery module 191 • BCM 188 • CVT 187 • Generation mode 191 • Heat sink 196 • IMA 187 • IPU 189 • i-VTEC 187 • MCM 190 • MDM 189 • PCU 195 • VCM 187 • VTEC 186

### Objectives

1. Identify Honda hybrid electric vehicles.
2. Describe how the Honda Integrated Motor Assist (IMA) system works.
3. Explain the precautions necessary when working on Honda hybrid electric vehicles
4. Describe the features and the operational characteristics of Honda hybrid electric vehicles
5. Explain the service procedures for Honda hybrid electric vehicles.

## Lecture Resources:

### Search the Internet

1. Have students use the Internet to research “MIVEC” and write a brief report on this technology. Ask students to share their findings with the class. (Page 187)
2. Have students research the Internet for the Honda CVCC engine. Have them prepare a brief report on this technology. Ask them to share their findings. (Page 190)
3. Have students search the Internet for the company that patented the first CVT transmission. Ask students to share their findings with the class. (Page 192)
4. Have students search the Internet for manufacturers of three cylinder engines used in automobiles. Ask students to share their findings with the class. (Page 193)
5. Have students search the Internet for information about the 1902 series-hybrid runabout that competed against steam and gas-powered cars in a New York to Boston reliability test. Ask student to share their findings with the class. (Page 198)

**Cross-Curricular Activity: History-** Have the students research Robert Anderson of Aberdeen. Ask students to write a short paper on this electric vehicle historical person. (Page 186)

**Cross-Curricular Activity: History-** Have students research Stephenson valve gear. Ask students to share their findings with the class. (Page 188)

**Cross-Curricular Activity: History-** Have students research Immisch & Company. Ask students to share their findings with the class. (Page 189)

**Cross-Curricular Activity: History-** Have students research Walter Bersey. Ask students to share their findings with the class. (Page 191)

**Cross-Curricular Activity: History-** Have students research Austrian Dr. Ferdinand Porsche. Ask students to share their findings with the class. (Page 194)

**Cross-Curricular Activity: History-** Have students research Pope Manufacturing Company of Hartford, Connecticut. Ask students to share their findings with the class. (Page 195)

**ASSES**- Have the students properly identify all the components in the IPU compartment. Have the students give a brief description of each component. Grade them on accuracy and detail. (Page 196)

**Cross-Curricular Activity: History**- Have students research Pieper electric vehicles, Belgium. Ask students to share their findings with the class. (Page 197)

**Cross-Curricular Activity: History**- Have students research h piper engineer. Ask students to share their findings with the class. (Page 199)

**Cross-Curricular Activity: Mathematics**- Have the students calculate the change in speed caused by changing tire diameter. Have the students do the calculations for both increase and decreasing tire diameter. (Page 200)

**ASSES**- Have student prepare a paper on the Honda hybrid. Ask them to give brief descriptions of the technology used and why they think these technologies make this vehicle a good choice in hybrid vehicle. Ask them to present their paper to the class. (Page 201)

### **Additional Topics:**

1. <http://automobiles.honda.com/civic-hybrid/>
2. <http://autos.aol.com/honda/hybrid/>

### **Discuss**

1. Have students discuss Honda VTEC technology and give some advantages or disadvantages of the technology. (Page 186)
2. Have students discuss the important of valve adjustments on Honda engine. Have students locate a VECI and read the valve clearance specifications. (Page 186)
3. Have the students use the schools vehicle repair information system and look-up the I-VTEC system for a Honda hybrid vehicle. Have them put together a list of inputs and outputs that can be viewed on a scan tool. (Page 187)
4. Have students discuss the Variable Cylinder management (VCM) system, and compare this system with other VTEC control systems. (Page 187)
5. Have the students discuss the affects of engine oil on this type of system. Have them research the proper oil and recommended oil service schedule. Ask students to give possible engine oil related problems for this system. (Page 188)



6. Have students discuss the reasons for the IMA batteries to be kept at 80% charge versus 100% charge. Have students discuss battery life and cycling. (Page 188)
7. Have students form groups and discuss "What is a Green Driver?" and prepare examples of green driving habits. Also have them prepare none green driving habits. Have each group share their examples and be ready to defend their positions. (Page 189)
8. Have the students discuss the Honda hybrids use of a conventional 12-volt auxiliary starter motor and what are the situations for its use? (Page 189)
9. Have students discuss the different modes of operation IMA system. (Page 190)
10. Discuss the two deceleration modes of operation. Ask students to discuss if these modes would change their driving habits? (Page 191)
11. Have students discuss situations that would activate the ABS system on a Honda hybrid vehicle. Ask the students to list some reasons for why the manufacturer designed the system to perform this way. Ask them to share their ideas with the class. (Page 191)
12. Have the students discuss the restart condition for the ICE engine in a Honda Hybrid. (Page 192)
13. **Hans-on-** Have the students examine a Honda CVT on a bench. Ask students to identify major parts of the CVT transmission. (Page 192)
14. Have the students discuss the difference between rich and lean exhaust. What indicates that the engine is operating correctly? (Page 193)
15. Have the students discuss how an exhaust leak can cause a false lean condition. (Page 193)
16. **Hans-on-** Have the students use the schools repair information system and look-up a 2004 Honda Insight wiring schematic. Ask students to identify the LAF sensor circuit. (Page 194)

17. Have the students continue to use the wiring schematic and identify the IMA circuits. (page 194)
18. **SAFETY**-Review hybrid safety with the students and quiz them on safety procedures. Have them research safety procedures for removing a battery module in a 2004 Honda Insight vehicles. (Page 195)
19. Have the students use the schools automotive repair information system to find the fuse locations in a Honda hybrid vehicle. Ask students to locate the ESP fuse in the fuse box diagram. (Page 196)
20. **SAFETY**-Review hybrid safety with the students and quiz them on safety procedures. Have them research hoisting procedures for a Honda hybrid vehicle. (Page 197)
21. Discuss servicing the 12-volt battery on a Honda hybrid. Ask students what procedures different from none hybrid vehicle. (page 197)
22. Ask the students to discuss the advantages and disadvantages of electronic steering. Have students discuss the special procedures for wheel alignment. (Page 198)
23. Discuss the Airbag systems use in safety. (Page 198)
24. Ask students to discuss the effects of replacing an automobile's tires with smaller-sized tires. (Page 199)
25. Ask the students to discuss the effects of replacing an automobile's tires with larger-sized tires. (Page 199)
26. Discuss with the students Low-E tire technology (Page 199)
27. Discuss with students that in 1913 with the advent of the self-starter (making it easy for all drivers to start gas engines), steamers and electrics were almost completely wiped out. In this year, sales of electric cars dropped to 6,000 vehicles, while the Ford Model T sold 182,809 gasoline cars (Page 200)

28. Have student use the school automotive repair information system to research available scan data on a Honda hybrid. Ask them to share their findings with the class. (Page 200)
29. Have the students discuss the information on Page 201 and give some possible customer complaints associated with this tips and real world fixes.
30. **Hands-On-** Have student look up TSB information for Honda vehicles. Have them pick one TSB to present to the class for discussion. (Page 201)

## **Demonstrate**

1. Using a scan tool show students data related to a Honda VTEC system operation (Page 186)
2. Using a scan tool show students data related to a Honda i-VTEC system. (Page 187)
3. Using a scan tool show students the IMA data available through the body control module (BCM). Discuss this data with the students. (Page 188)
4. Show the students the difference between a deep cycle battery and a conventional battery. (Page 188)
5. Show the students how the features of the Honda display works. (page 189)
6. If available, allow student to operate an IMA system in the school parking lot. (Page 190)
7. Show the student idle stop operation on a Honda hybrid vehicle (Page 191)
8. Show the students how to build a data list that will show the AC system operation. Select the two modes of AC operation and capture a file to review with the students in class. (Page 192)
9. Using a scan tool graph a LAF sensor with the students and make a file. Graph several other types of oxygen sensors and show the students the difference in response time to exhaust changes from rich to lean. (Page 193)
10. Show the students the orange plastic shielding identifying the high voltage circuits to the batteries. (Page 195)

11. Show the students the IPU compartment and discuss each component located in the IPU. (Page 195)
12. Show the students the location of the EPS fuse. Remove the fuse and show the students the battery charging procedure for a Honda hybrid being stored. (Page 196)
13. Show the students the proper lift points of a Honda hybrid. Hoist the Honda hybrid and show the students the IMA unit between the engine and transmission. (Page 197)
14. Show the students the location of the conventional 12-volt battery in a Honda hybrid vehicle. (Page 197).
15. Show the students an electronic steering unit from a Honda hybrid. (Page 198)
16. Using a scan tool show the students the operation of electronic steering through the scan tool data. (page 198)
17. Show students the mathematics for solving outer tire diameters. Be sure to use a couple of examples that have different rim and tire sizes but calculate to the same outside diameter. (Page 199)
18. Show student how to depower the HV system on a Honda. (Page 200)
19. Show students the available information on Honda hybrid vehicles with different scan tool. Have students compare information available. (Page 200)

## **Student Activities**

1. MAL Chapter 71 Animation Basic Information Processing
2. MAL Chapter 76 Animation Oxygen Designation
3. MAL Chapter 79.2 Animation Direct Fuel Injection
4. MAL Chapter 86 Animation Three-way catalytic Converter
5. MAL Chapter 109.1 Activity Tire size designation

## **Review Questions / Answers**

- 1 What are the differences in the engines used in Honda hybrid vehicles as compared to similar non-hybrid vehicles? (Text pages 193-194; 198)

**The Honda Insight engine uses indexed spark plugs in a three-cylinder engine. The Civic hybrid and**

**Accord use a different VTEC system than other Honda vehicles that shuts off cylinders during deceleration to increase regenerative braking.**

2. What features are used on the Honda Accord hybrid to reduce noise and vibration? (Text page 187)

**The Honda Accord uses active noise cancellation (ANC) to reduce the effects of operating on three of the six cylinder.**

3. What is the difference between fuel-cut mode and idle stop mode? (Text page 191)

**Fuel shut off turns off fuel injection during deceleration whereas auto stop shuts off the engine when the vehicle stops moving.**

4. What are the conditions that must be met for auto idle stop to occur? (Text page 191)

**Auto stop only occurs after the engine is warm and when there is no need for propulsion. Engine stop can occur :**

- a. at vehicle speed below 19 mph**
- b. when the transmission is in any gear except first gear during deceleration**
- c. when engine speed is less than 1,000 RPM**

5. How is the high-voltage electrical system disconnected in a Honda hybrid electric vehicle? (Text page 200)

**The high-voltage system is disconnected when the ignition is turned off. However, to be sure, a service switch behind the rear seat must be switched to the "off" position. Disconnection the 12-volt auxiliary battery will also help ensure that the high-voltage system is de-powered.**

6. What are the safety and service procedures when working on Honda hybrid electric vehicles? (Text page 198)

**Always follow the factory recommended service procedures and carefully read, understand, and follow all warning labels.**

## CHAPTER QUIZ QUESTIONS AND ANSWERS:

1. What is unique about the three-cylinder Insight and the four-cylinder Civic engines? (Text page 193)
  - a. Both use indexed spark plugs
  - b. Offset crankshaft X**
  - c. Direct-injection fuel injection
  - d. No 12-volt starter motor
  
2. When the V-6 Accord hybrid engine is operating on three cylinders, what is done to reduce the noise and vibration? (Text page 187)
  - a. Retards the ignition timing to reduce noise and vibration in the cylinders
  - b. Uses active engine mounts
  - c. Uses active noise control
  - d. Both b and c X**
  
3. Most Honda hybrid electric vehicles have a dash display that indicates \_\_\_\_\_ and \_\_\_\_\_. (Text page 188)
  - a. Assist/charging X**
  - b. Power/economy
  - c. Cruise/idle
  - d. Deceleration/acceleration
  
4. Honda hybrids will use the 12-volt battery and conventional starter motor under what conditions? (Text page 189)
  - a. SOC of the battery module is low
  - b. Ambient temperature is below 0°F (-18°C)
  - c. A failure of the IMA system

**d. Any of the above X**

5. The state of charge of the high-voltage batteries is usually commanded to be \_\_\_\_\_. (Text page 188)

**a. 50% to 80% X**

b. 10% to 50%

c. 10% to 70%

d. 80% to 100%

6. Which of the following conditions will prevent the ICE from entering idle stop mode? (Text page 191)

a. The transmission is in reverse gear

b. The ICE has not entered closed loop

c. Air conditioning is in "auto" mode

**d. All of the above are correct X**

7. The LAF sensor is capable of measuring air-fuel ratios as lean as \_\_\_\_\_. (Text page 193)

a. 12:1

b. 14.7:1

**c. 25:1 X**

d. 30:1

8. The high-voltage batteries used in Honda hybrid electric vehicles are \_\_\_\_\_. (Text page 195)

a. One large battery module

b. 144 one-volt batteries

**c. Made up of D-cell-size batteries X**

d. 12 VRLA batteries connected in series

9. Where are the MCM and BCM located? (Text page 195)

- a. **Behind the rear seat**    X
- b. Under the rear seat
- c. Under the hood by the passenger-side strut tower
- d. Under the passenger-side seat

10. How are the batteries cooled? (Text page 195)

- a. Coolant cooled
- b. **Air cooled**    X
- c. Air conditioning evaporator cooled
- d. Both a and b

## **ASE / NATEF Correlation Charts**

1.

### **Suggestions for related instruction (web links / books / movies / etc.)**

1. <http://www.youtube.com/watch?v=xmDkc8SEvwc>
2. <http://www.youtube.com/watch?v=-lYDYTE0T1k&feature=related>
3. [http://www.youtube.com/watch?v=MCtd\\_9-lcaU&feature=related](http://www.youtube.com/watch?v=MCtd_9-lcaU&feature=related)
4. <http://www.youtube.com/watch?v=stJM9EvZRgQ&feature=related>
5. <http://www.youtube.com/watch?v=15qeygZhLzo&feature=related>



# Chapter 13

## Toyota/Lexus Hybrid Vehicles

### Chapter Summary

1. The first-generation Prius was introduced in 2001 in the United States and the second generation was released in 2003 as a 2004 model.
2. The Prius engine uses the Atkinson cycle and displaces 1.5 liters.
3. The TH's inverter is cooled by the same heat exchanger as the transaxle.
4. The Prius is ready to be driven when the ready light is on steady (steady ready).
5. The high-voltage battery packs on Toyota hybrids are air cooled using vents on the outside or alongside the rear seat.
6. The Lexus RX 400h has an optional rear motor, giving the vehicle four-wheel-drive capability.
7. Care should be taken when driving a Toyota hybrid in parking lots or at slow speeds in or around the shop because it operates on battery power alone under these conditions and others may not hear the vehicle approach.

### Key Terms

Boost converter 212 • Coefficient of drag (Cd) 203 • ECB 215 • EPS 215 • ETC 214 • Hybrid synergy drive 203 • Inverter 212 • PID 211 • Smart key 208 • SMR 210 • THS 211 • TRAC 215 • VDIM 215 • VIN 203 • VSC 215 • VVT-i 214

### Objectives

1. Identify a Toyota/Lexus hybrid electric vehicle.
2. Explain the operation of the various unique systems found in Toyota/Lexus hybrid electric vehicles.
3. List the procedures necessary to depower the high-voltage circuits in Toyota/Lexus hybrid electric vehicles.
4. Describe how to safely perform routine service on a Toyota/Lexus hybrid electric vehicle.

### Lecture Resources:

#### Search the Internet

1. Have the students search the Internet for how shapes affect the coefficient of drag of a vehicle. Have the students share their findings with the class. (Page 203)

2. Have students search the Internet for products that help drivers “driving green”. Have student share their findings with the class. (Hint-vacuum gage). (Page 205)
3. Have student search the Internet for the first use of “by wire “technology. Have them share their findings with the class. (Page 206)
4. Have students search the Internet for bladder fuel tanks use in other types of vehicles. Ask students to share their findings with the class. (Page 209)
5. Have the students use the Internet to research TRW’s contribution to hybrid technology in the area of electromechanically transmission. Ask students to share their findings with the class. (Page 210)
6. Have students use the Internet to research Toyota Motor Corporation "Earth Charter," Ask students to share their findings with the class. (Page 211)
7. Have students use the Internet to research Public Law 94-413. Ask students to prepare a paper on this law and present their findings to the class. (Page 213)
8. Have the students use the Internet to identify alternative power supplies- Independent and /or self-sustaining-that can support heating and air conditioning systems in hybrid vehicles. Have students create a chart that depicts the alternative sources and share their work with the class. (Page 214)
9. Have students use the Internet to research electric power steering systems and hydraulic steering systems. Ask them to compare the two systems, listing the advantages and disadvantages of each system. (Page 215)
10. Have students use the Internet to research stability control laws for vehicles sold within the United States. Ask student to prepare a paper on the laws for vehicle stability control systems. (Page 216)
11. Have students use the Internet to research The Partnership for a New Generation of Vehicles (PNGV). Ask student to prepare a paper on groups activities. (Page 217)
12. Have students use the Internet to research the Toyota G21 project. Ask student to prepare a paper on this Toyota project. Discuss with students that this project was a result of not being a part of the PNGV group. (Page 218)
13. Have the students use the Internet to research manufactures of CAT III meters. Ask the students to compare prices and features. Have students share their findings with the class. (Page 220)

14. Have students search the Internet for first responder training for hybrid vehicle accidents. Ask students to share their findings with the class. (Page 221)

**ASSES-** Provide the students with common warning symbols used on hybrid vehicle dashboard cluster assemblies. Have them identify the meaning of each symbol. Grade students on their ability to identify the symbols and the systems associated with them. (Page 204)

**Cross-Curricular Activity: History-** Have students research Baker of Cleveland electric vehicles. Ask students to share their findings with the class. (Page 207)

**Cross-Curricular Activity: History-** Have students research Victor Wouk and Charlie Rosen. Ask students to share their findings with the class. (Page 212)

**Career Preparation-** Have students research hybrid job opportunities in your area. Have them research pay and training needed. Are there any certifications needed? (Page 219)

### **Additional Topics:**

1. [http://www.toyota.com/prius-hybrid/?srchid=bing|Hybrid\\_Prius|toyota\\_prius&srchid=K1263\\_p12999167](http://www.toyota.com/prius-hybrid/?srchid=bing|Hybrid_Prius|toyota_prius&srchid=K1263_p12999167)
2. <http://www.edmunds.com/toyota/prius/2011/>
3. <http://www.mpgomatic.com/2008/04/06/lexus-rx400h-review/>

### **Discuss**

1. **Hans-on-** Have the students decipher the VIN on a shop or personal vehicle. (Page 203)
2. Ask the students to discuss the emissions rating used to categorize Tier 2 vehicles types under the Clean Air Act Amendments (CAAA) of 1990. Ask them to identify a ULEV and a ZEV vehicle. Students may use the Internet to determine which vehicles fall into these categories. (Page 203)
3. Have students discuss the importance of indicator, or warning lights. What is the purpose of a dash warning light? (page 204)
4. Discuss with students how engine vacuum has a direct relationship to fuel consumption. (Page 205)

5. Have the students discuss the advantages and disadvantages of “by wire” technology. (Page 206)
6. Have student discuss engine “RED LINE” and why is it important to understand. (Page 207)
7. **SAFETY**- review with students why the smart key must be stored correctly while servicing a hybrid. (Page 208)
8. Discuss the effects of polish and wax on the smart key door handles. (Page 208)
9. Review HC and CO emissions and catalyst light-off temperatures. (Page 208)
10. Have students discuss the closed fuel tank system used by Toyota. Ask students to debate the advantages and disadvantages of the system. (Page 209)
11. Have students discuss why no late model vehicle should be run out of gasoline. Explain how the fuel pump is cooled by being submerged in fuel. (Page 209)
12. **Hands-On**-Have students use the school repair information system and look up the wiring schematics for the Prius. Have them locate the HV circuits and highlight them. (Page 210)
13. **Hands-On**- Have students use a scan tool and monitor HV data. Ask students to create a file of the data available for HV battery diagnosis. (Page 211)
14. **Hands-On**- Have students use the schools repair information system and research codes associated with the HV battery system. Ask students to put a short presentation together about these codes and procedures. (Page 211)
15. Discuss with students the electrical problems that affect the traditional 12-volt system wiring and connectors affects the HV system also. (Page 211)
16. Have students discuss the MG1 and MG2 function in a Toyota hybrid. (Page 212)
17. **Hands-On**- Have students use the schools repair information system and research codes associated with the MG1 and MG2 system. Ask students to put a short presentation together about these codes and procedures. (Page 212)
18. Ask student to review inverters and discuss how they work. (Page 213)
19. Have students discuss Variable Valve timing with intelligence (VVT-i) operation. (Page 214)
20. Have students discuss electronic throttle Control (ETC) (Page 214)

21. Have students talk about driving conditions in which they would deactivate the traction control system (Page 216)
22. Ask student to research what a Tier 2 BIN 2 emissions standard is. Have them discuss what a SULVE is. (Page 216)
23. **SAFETY**- Review with students why the smart key must be stored correctly while servicing a hybrid. (Page 217)
24. **SAFETY**- Review with students the “READY Light” meaning and how to deactivate the system. (Page 217)
25. Have students use a factory scan tool and non factory scan tool to access a Toyota hybrid vehicle. Ask students to compare the difference between scan tools. (Page 218)
26. Using figure 13-30 have the students discuss the two modes (Page 219)
27. Ask students to review oil viscosities and ISLAC, API standards. (Page 220)
28. Have students use the school repair information system to look up maintenance TSBs for Toyota hybrid vehicles. (Page 221)
29. Have students look up proper fluids and capacities for the common maintenance areas of a Toyota hybrid. Ask students to identify uniqueness of some hybrid fluids used. (Page 222)

## **Demonstrate**

1. Show students how different shape move through a fluid (water) and explain the design can affect fuel usage. (Page 203)
2. Demonstrate to the students a Toyota Prius dashboard in operation. Show the students how the “READY” light works. (Page 204)
3. Demonstrate the Toyota Prius energy monitor (Page 205)

4. Using a scan tool on a Toyota Prius show the students the amount of data available to a technician to troubleshoot brake by wire and throttle controller. (Page 206)
5. Show students using a scan tool data for the shift control actuator. Ask students to operate the shifter and monitor data to see shift control actuator operations. (Page 207)
6. Show the students the effects of wax or polish on the door handle of a smart key hybrid. (Page 208)
7. If available show students how the closed fuel tank system works on a Toyota. Show the students the location of the override opener. (Page 209)
8. Show students first generation Prius battery pack. (Page 210)
9. Show students using a scan tool the MG1 and MG2 operation and the data available to assist with diagnosis. (Page 212)
10. Show students a Toyota inverter and discuss the parts of the inverter. (Page 213)
11. Using a scan tool show students the data for a VVT-I system on a hybrid vehicle. (Page 214)
12. Show students examples of power steering analyzers. (Page 215)
13. Show students how to connect a power steering analyzer to a power steering system. (Page 215)
14. Show the students sensors used in self-parking units (Page 215)
15. Show the students the operation of a RX400h dash if available. (Page 216)
16. Show students how to depower the HV system in a Toyota hybrid vehicle. (Page 217)
17. Show students several different scan tools used on Toyota hybrid vehicles. (Page 218)
18. Show students the proper operation of a meter to check HV systems. (Page 220)
19. Hoist a Toyota hybrid and show students service points and access points (Page 221)

## Student Activities

1. NO My Automotive Lab (MAL) activities

## Review Questions / Answers

1. . What is unique about starting a Prius? (Text page 207)

**The Prius is started by depressing the brake pedal and pushing the start button. The gasoline engine may or may not start depending on the temperature of the engine and other variables. When the ready light is on this is the indicator to the driver that the vehicle is ready to be driven.**

2. What are the functions of the inverter in a Toyota HEV? (Text page 212)

**The inverter changes battery direct current (DC) into alternating current (AC) for use by the traction motors.**

3. What is the procedure for disconnecting the high-voltage circuits on a Toyota HEV? (Text page 217)

**Step 1 – Turn the ignition system off (ready light off)**

**Step 2 – Disconnect the 12-volt auxiliary battery**

**Step 3 – Remove the orange high-voltage service plug while wearing high-voltage linesman's gloves**

**Step 4 – Wait five minutes before servicing any high-voltage system or component**

4. What are the precautions when working on Toyota hybrid vehicles? (Text page 217)

**1. Always de-power the high-voltage system before touching or servicing any high-voltage component or system.**

**2. Wait at least five minutes to allow time for the high-voltage capacitor to discharge**

**3. Always wear high-voltage linesman's gloves when working on the high-voltage system.**

## CHAPTER QUIZ QUESTIONS AND ANSWERS:

1. Where is the 12-volt auxiliary battery located in a Toyota Prius? (Text page 204)
  - a. Under the back seat
  - b. Under the hood, driver's side
  - c. In the trunk X**
  - d. Under the hood, passenger's side
  
2. Pressing the POWER button one time, without depressing the brake pedal, causes the system to enter what mode? (Text page 207)
  - a. Accessory X**
  - b. Ignition on
  - c. Ready
  - d. Vehicle started
  
3. On a Prius, what does the "B" mean on the shift indicator? (Text page 206)
  - a. Battery
  - b. Braking X**
  - c. Back up
  - d. Booking
  
4. The energy monitor screen on a Toyota Prius shows the driver all of the following, *except* \_\_\_\_\_. (Text page 205)
  - a. When the gasoline engine is powering the vehicle
  - b. When the electric motor is powering the vehicle
  - c. When the gasoline engine is charging the high-voltage batteries
  - d. When the rear motor is generating electricity during braking X**



5. In order for a Toyota Prius to start, what has to be OK? (Text page 207)
- a. The high-voltage battery pack must be sufficiently charged to crank the engine.
  - b. The auxiliary 12-volt battery must be sufficiently charged.
  - c. The brake pedal must be depressed.
  - d. All of the above X**
6. The Toyota Prius, Highland, and Lexus RX 400h are all what type of hybrid electric vehicle? (Text pages 203; 214)
- a. Full (strong)**
  - b. Medium
  - c. Mild
  - d. Plug-in
7. The Lexus RX 400h hybrid electric vehicle uses which of the follow systems? (Text page 215)
- a. VDIM
  - b. ETC
  - c. EPS
  - d. All of the above X**
8. Toyota HEV service is being discussed. Technician A says that the service plug should be removed anytime the HV system is being serviced. Technician B says the service plug should be secured to prevent another technician from installing it while you are servicing the vehicle. Which technician is correct? (Text page 217)
- a. Technician A only
  - b. Technician B only
  - c. Both Technicians A and B X**
  - d. Neither Technician A nor B

9. The high-voltage batteries in Toyota hybrid electric vehicles are cooled by \_\_\_\_\_. (Text page 210)

- a. Coolant
- b. An air-conditioning evaporator
- c. Cabin air X**
- d. Phase-change liquid

10. Where is the high-voltage disconnect plug on a Prius? (Text page 217)

- a. Under the hood, passenger's side
- b. To the left of the driver, next to the seat
- c. In the trunk X**
- d. Under the hood, driver's side

## **ASE / NATEF Correlation Charts**

1.

### **Suggestions for related instruction (web links / books / movies / etc.)**

- 1. <http://www.youtube.com/watch?v=X9dyADHwK74>
- 2. <http://www.youtube.com/watch?v=FUsZhqjA93c>
- 3. <http://www.youtube.com/watch?v=uKL8qIJuO40>

# Chapter 14

## Ford/Mercury Hybrid Vehicles

### Chapter Summary

1. The Ford Escape and Mercury Mariner hybrids share most of the same components except for trim and other nonhybrid features.
2. The Ford/Mercury hybrids are full (strong) hybrids and are capable of propelling the vehicle using battery power alone.
3. The Ford/Mercury hybrids both use an electronically controlled continuously variable transmission (eCVT).
4. The generator motor in the eCVT has three functions: generating electric current, starting the gasoline engine, and controlling the drive ratio within the transaxle to keep the gasoline engine within its most efficient speed and load range.
5. The high-voltage battery pack is located under the floor at the rear of the vehicle. The batteries are air-cooled.
6. The 12-volt battery is a flooded lead–acid design and is located under the hood.
7. The Ford/Mercury hybrids use an electric power steering system.
8. Service procedures include setting up a buffer zone around the vehicle and depowering the high-voltage circuits.
9. Two fuses must be removed from the battery junction box (BJB) before servicing the brake system. A scan tool can also be used to place the system in “Brake Pad Replacement Mode.”

### Key Terms

• Ah 231 • BJB 234 • eCVT 225 • EPAS 231 • Floating Ground 229 • Green Zone 225 • Helper Pump 226 • HVTB 229 • RBS 232

### Objectives

1. Explain the operation of a Ford/Mercury hybrid electric vehicle (HEV).
2. Describe the features of a Ford/Mercury HEV.
3. Discuss the safety precautions to be followed whenever working on a Ford/Mercury HEV.
4. Explain how the electronically controlled continuously variable transmission (eCVT) allows the Ford/Mercury HEV to achieve maximum efficiency.
5. Describe the service procedures for Ford/Mercury HEVs.

### Lecture Resources:

## Search the Internet

1. Have the students use the Internet to research the European counterpart to the Ford Escape in the US. Ask students to explain the differences and the name used for the Escape in Europe. (Page 224)
2. Have the students use the Internet to research the Pent-roof combustion chambers. Ask students to prepare a report to share with the class. (Page 226)
3. Have the students use the Internet to research hybrid training for towing companies. Ask students to share their findings with the class. (Page 230)
4. Have students use the Internet to research after market electronic steering components. Have students share their findings with the class. (Page 232)
5. Have students use the Internet to research bus applications of series regenerative brake system. Ask the students to share their findings with the class. (Page 233)
6. Have students use the Internet to research high voltage personal safety equipment available. Ask students to write a paper on their findings. Ask them to share their findings with the class. (Page 234)

**ASSES-** Have students use the schools repair information system and look up the warning lights available in a Ford escape hybrid. Ask students to give a description of each warning lamp in a report. Grade the students on accuracy and detail. (Page 225)

**Cross-Curricular Activity: Science-** Ask students to research the properties of charcoal as a filtering substance. Ask the students to share their findings with the class. (Page 227)

**ASSES-** Have the students identify the parts of a planetary gear set. Grade them on their ability to correctly identify parts including the sun gear, the planetary carrier, and the ring (annulus) gear. (Page 228)

**Cross-Curricular Activity: Science-** using a repair manual , have the students look up what the gear ratio for all forward gears are in a hybrid and a none hybrid Escape. Have the students graph the results of each vehicle. Are there any similarities? Ask them to report their findings to the class. (Page 229)

**ASSES-** Have students use the schools repair information system to research high voltage converter/inverter DTCs and high voltage traction battery DTCs. Ask students to prepare a brief report on the information they found. Have them share this report with the class. (Page 231)

**ASSES-** Have students set up the service area for servicing a hybrid vehicle. Grade them on setting up the area correctly, personal protective equipment inspection and donning. Having all safety related items placed nearby for access. (Page 235)

### **Additional Topics:**

1. <http://www.hybridcars.com/vehicle/ford-fusion-hybrid.html>
2. <http://www.hybridcars.com/vehicle/ford-c-max-hybrid.html>

### **Discuss**

1. Have student talk about the physical differences between the non-hybrid Escape and the hybrid Escape. (Page 224)
2. Review with the students the importance of understanding the vehicle warning lamps and what systems that are associated with. (Page 225)
3. Ask the students to research the optional equipment for a Escape/Mariner to have a 1,000 pound tow capacity. (Page 225)
4. Have the discuss intake runner valves and reduced airflow to cylinders. What advantage or disadvantage is there to this type of system? (Page 226)
5. Have students discuss the 2.3 liter engine used by Ford. Ask students to talk about how long has this engine been in use by Ford? (Page 226)
6. Review with the students the Atkinson cycle. (Page 227)
7. Discuss with students why a charcoal filter is able to contain hydrocarbons (HC). (Page 227)
8. **SAFETY-** Caution the students that parts on a planetary gear set can be very sharp and can cause personal injury. Also warn the students that planetary gear sets have many pinch points that also can cause injury. (Page 228)
9. **Hands-on-** Have the students work in groups to experiment with a planetary gear set. Ask them to hold and drive different parts of the gear set to see what the results will be. Ask them to determine when a gear reduction. A 1:1 ratio or an overdrive will occur. (Page 228)
10. Ask the students to discuss why some 4WD systems can be primarily front wheel drive (FWD) or primarily rear wheel drive (RWD). Have students talk about the advantages or disadvantages of using one or the other. (Page 229)

11. Have students use the schools repair information system to look up hybrid 4WD vehicles that are primarily front wheel drive and rear wheel drive. Have the students share their findings with the class. (Page 229)
12. Discuss with students what floating ground means. (Page 229)
13. **SAFETY** -Review hybrid safety with students and the responsibility they have for following them (Page 230)
14. Discuss the types of DTC's a hybrid can use to alert the technician to possible faults. (Page 231)
15. Discuss the temperature problems associated with large amounts of electricity flowing through a motor. Ask students why temperature control has an effect on the electrical components life cycle. (Page 232)
16. Ask students to discuss the difference between a series regenerative brake system and a non-series regenerative brake system. (Page 233)
17. Ask students to discuss the affects of each system on the service brake maintenance. (page 233)
18. **Hands-on-** Have the students work in groups to compare ABS codes of a hybrid with ABS codes of a none hybrid vehicle. Ask them to identify the differences in each vehicle. Ask them to share their findings with the class. (Page 233)
19. Discuss best practices with students for managing the service disconnect plug for the HV system in a ford hybrid. (Page 234)
20. Discuss the bleeding procedure with the students of a hybrid vehicle. Have students write down the differences in servicing the hybrid system versus a none hybrid system. (page 234)
21. Discuss with students the importance of having the proper voltage available during the brake service procedures. (Page 235)
22. Ask students to discuss chart 14-1 and discuss the importance of this information. (Page 235)

## **Demonstrate**

1. Show the student a Ford Escape and Mariner; point out the similarities and differences. Compare both to their non-hybrid counterparts. (Page 224)

2. Show the students the warning lamps in a Ford hybrid. Explain how some of these lamps will only remain on during a brief period of self-test. (page 225)
3. Show students a four orifice fuel injector and a single orifice fuel injector. (Page 226)
4. Show students a coolant system helper pump in the classroom. Take students out a vehicle and show them a helper pump mounted in the vehicle. (Page 226)
5. Show students how charcoal material will retain hydrocarbons. (Page 227)
6. Show the students a planetary gear set from an automatic transmission. Identify the parts including the sun gear, the planetary carrier, and the ring (annulus gear). (Page 228)
7. Show students the proper procedure for jump starting a Ford hybrid Escape with a jump box. Be sure to review all cautions and safety steps that should be taken during this procedure. (Page 230)
8. Show students the proper procedure for jump starting a Ford hybrid Escape with jumper cables and another vehicle. Be sure to review all cautions and safety steps that should be taken during this procedure. (Page 230)
9. Show student how to retrieve faults from the hybrid vehicles computer systems. Discuss the imports of freeze frame data. (Page 231)
10. Show student high voltage system data on a scan tool. (Page 231)
11. Show students the cooling system parts of a transaxle DC converter. (Page 232)
12. Show the students and electronic steering torque sensor housing. (Page 232)
13. Show students data from the ABS system using a scan tool. (Page 233)
14. Show students the procedure for depowering a Ford hybrid vehicle. (Page 234)
15. Using a scan tool and appropriate brake bleeding equipment, show students how to bleed the brake system of a Ford hybrid vehicle. (Page 234)
16. Show the students how to service the battery zone air filter. Ask them to price this filter from a dealer and then aftermarket. (Page 235)

## Student Activities

1. MAL None

## Review Questions / Answers

1. What are the differences between the Ford Escape hybrid and the Mercury Mariner hybrid? (Text page 224)

**The main differences are in the design of interior and exterior, whereas the mechanical aspects are the same for both.**

2. How do the Ford/Mercury hybrids compare to other hybrid vehicles? (Text page 225)

**The Ford/Mercury hybrids are full (strong) hybrids, which means that the vehicle can be propelled using electric power alone similar to the Toyota/Lexus hybrids. Other mild or medium hybrids are not capable of powering the vehicle using electric power alone and must have the ICE running whenever the vehicle is moving.**

3. What are the features that are different about the Ford Escape and Mercury Mariner hybrids compared to the non-

hybrid version of the same vehicle? (Text pages 224-225)

**The main differences between the hybrid and non-hybrid versions is the dash display and the small air vent in the left rear quarter glass used to cool the batteries on the hybrid.**

4. What safety precautions should be followed when working on the Ford Escape and Mercury Mariner hybrids?

(Text page 233)

**Ford and Mercury specify that the following safety precautions must be followed:**

1. Place cones around the vehicles as a buffer zone.
2. Remove the service disconnect plug and place it in the shipping position.
3. Wear high-voltage linesman's gloves.
4. Wear a face shield.
5. Have a fiberglass hook available outside of the buffer zone.



## CHAPTER QUIZ QUESTIONS AND ANSWERS:

1. The auxiliary 12-volt battery does all of the following, *except* \_\_\_\_\_. (Text page 231)
  - a. **Powers the starter motor to crank the engine** X
  - b. Stores electrical energy for later use
  - c. Acts as a voltage stabilizer
  - d. Provides temporary power
  
2. The vent located at the left rear of the vehicle is used to \_\_\_\_\_. (Text page 224)
  - a. Provide cool air for the gasoline engine
  - b. **Cool the high-voltage battery pack** X
  - c. Cool the vehicle system controller (VSC)
  - d. Both a and b
  
3. The Ford Escape and Mercury Mariner hybrid gasoline engines use the Atkinson cycle. This means that the engine \_\_\_\_\_. (Text pages 226-227)
  - a. Has eight cycles instead of four cycles
  - b. Has no spark plugs
  - c. Uses just one valve per cylinder
  - d. **Delays the closing of the intake valves** X
  
4. The Ford and Mercury hybrid transaxles contain \_\_\_\_\_. (Text page 227)
  - a. A 45-kw AC generator motor
  - b. A 70-kw AC traction motor
  - c. Planetary gears and final drive gears

**d. All of the above** X

5. The Ford and Mercury hybrids are what type of hybrid? (Text page 224)

a. Series

**b. Full (strong)** X

c. Medium

d. Mild

6. What type of battery is used in the high-voltage system? (Text page 229)

**a. 250 D-size batteries** X

b. One large NiMH battery

c. VRLA batteries

d. None of the above

7. The DC-DC converter is located \_\_\_\_\_ and cooled by \_\_\_\_\_. (Text pages 231-232)

**a. Under the hood; a liquid cooling system** X

b. Under the rear floor; a liquid cooling system

c. Under the rear floor; air cooled

d. Under the hood; air cooled

8. The Ford/Mercury hybrids use all of the following, *except* \_\_\_\_\_. (Text page 230)

a. Regenerative braking

b. Electric power-assist steering

**c. 12-volt starter** X

d. Idle stop capability

9. Ford and Mercury specify that the following precautions be observed when working on the high-voltage system:

(Text pages 233-234)

- a. Create a buffer zone around the vehicle using cones.
- b. Wear linesman's gloves with leather gloves over them.
- c. Wear a face shield.
- d. **All of the above** X

10. What precaution(s) is/are needed before servicing the disc brakes on a Ford/Mercury hybrid vehicle? (Text page

234)

- a. Remove the brake fluid from the master cylinder.
- b. Disable the high-voltage system.
- c. **Disconnect two fuses.** X
- d. Unplug the electronic controller.

## ASE / NATEF Correlation Charts

1.

### Suggestions for related instruction (web links / books / movies / etc.)

- 1. <http://www.youtube.com/watch?v=00JYCn2fPY8>
- 2. [http://www.youtube.com/watch?v=UdLTEpA1b\\_4](http://www.youtube.com/watch?v=UdLTEpA1b_4)
- 3. <http://www.youtube.com/watch?v=iRI5PymBFy8>
- 4. [http://www.youtube.com/watch?v=w20T\\_7lhHo0](http://www.youtube.com/watch?v=w20T_7lhHo0)

# Chapter 15

## General Motors Hybrid Vehicles

### Chapter Summary

1. The General Motors parallel hybrid truck (PHT) uses three conventional VRLA 12-volt batteries connected in series to provide 36 volts (42 volts charging).
2. The flywheel alternator starter (FAS) is used to start the gasoline engine, provide torque smoothing, and generate electrical energy for the 120-volt outlets.
3. The PHT has four auxiliary power outlets (APOs)—two at the base of the rear seat and two in the bed of the truck.
4. The Saturn, Buick, and Chevrolet Malibu hybrid vehicles use a Belt Alternator Starter (BAS) system and 36-volt NiMH or 115-volt Li-ion battery packs.
5. The General Motors two-mode hybrid electric vehicle uses two 60-kW electric motors inside the transmission and can power the vehicle using electrical energy alone.
6. The two-mode hybrid vehicle is a full (strong) hybrid and uses a 300-volt NiMH battery pack located under the rear seat.
7. The Chevrolet Volt is an extended range electric vehicle that uses a 16-kW lithium-ion battery and a four-cylinder gasoline engine to help propel the vehicle and to keep the high-voltage battery at about 25% to 35% state-of-charge to extend the driving range of the vehicle.

### Key Terms

Auxiliary power outlet (APO) 240 • Belt alternator starter (BAS) 242 • Drive motor/Generator Control Module (DMCM) 247 • Electric machine (EM) 238 • Electro-hydraulic power steering (EHPS) 241 • Flywheel alternator starter (FAS) 238 • Parallel hybrid truck (PHT) 238 • Valve-regulated lead-acid (VRLA) 239

### Objectives

1. Identify General Motors hybrid electric and extended range electric vehicles
2. Describe how the parallel hybrid truck system works.
3. Describe the features and operating characteristics of the Saturn, Chevrolet, and Buick mild hybrids, and two-mode hybrid vehicles.
4. Describe how the Chevrolet VOLT works
5. Explain the precautions necessary when working on General Motors hybrid vehicles.
6. Explain the service procedures for General Motors hybrid vehicles.

## Lecture Resources:

### Search the Internet

1. Have students search the Internet for information on the GM 512 hybrid. Ask students to prepare a paper on this vehicle. Have students share their findings with the class. (Page 238)
2. Have students search the Internet for information on AM General and the USPS. What was the first year this company delved electric vehicles? How may? Ask students to prepare a paper on this vehicle. Have students share their findings with the class. (Page 239)
3. Have students search the Internet for information on typical household appliances. Ask students to prepare a paper on the power requirements of these appliances. Have students share their findings with the class. (Page 240)
4. Have students search the Internet for information on typical household GFI outlets. Ask students to prepare a paper on use and placement of these outlets. Have students share their findings with the class. (Page 241)
5. Have students search the Internet to identify suppliers of BAS conversion systems. Are there any available? Ask students to summarize their findings to share with the class. (Page 242)
6. Have students use the Internet to research the General Motors, Daimler Chrysler, BMW 2005 Joint Two Mode Hybrid Development Venture. Ask students to summarize their findings to share with the class. (Page 244)
7. Have students search the Internet to identify suppliers of two-mode transmissions. Ask students to summarize their findings to share with the class. (Page 245)
8. Have students use the school repair information system to research any cautions published by the manufacturer for servicing the two mode hybrid vehicles. Ask students to share their finding with the class. (Page 247)
9. Have the students research the Internet for extended range hybrid electric vehicles. Ask students to share their finding with the class. (Page 248)

**ASSESS-** Have students write a report on the common features of GM hybrids. Grade them on identifying idle stop, regenerative braking, power assist, and engine-off drive-electric vehicle mode, as well as their understanding of how each these features works. (Page 243)

**ASSESS-** Have students explain how using a planetary gears set can increase a smaller motors output torque. (Page 246)

**ASSESS-** Have students explain how to connect a Chevrolet to a charging appliance. Explain the information being displayed about the SOC of the batteries. (Page 250)

### **Additional Topics:**

1. [http://www.greencarreports.com/news/1021432\\_jaguar-extended-range-hybrid-two-seater-in-the-making](http://www.greencarreports.com/news/1021432_jaguar-extended-range-hybrid-two-seater-in-the-making)
2. <http://www.edmunds.com/gmc/sierra-1500-hybrid/2011/>
3. <http://www.hybridcars.com/vehicle/bmw-activehybrid-7.html>
4. <http://hybridvehicle-s.com/plug-in-electric-vehicles/>

### **Discuss**

1. Ask students to discuss fuel savings of the parallel hybrid truck to fleets. Ask students to calculate the fuel savings of a fleet that has 100 vehicles that average 15 MPG versus the hybrid delivering a 13% increase. (Page 238)
2. Discuss with students how fleets have a need to reduce energy consumption to meet government regulations. Ask students to research the Tax credit for a PHT from the federal government. (Page 238)
3. **SAFETY** -Review hybrid safety with students and the responsibility they have for following them (Page 239)
4. Discuss lead-acid battery technology and ask students to give some advantages or disadvantages of using this technology. (Page 239)
5. Ask students to discuss the relationship between ampere and watts. Ask students to convert watts to ampere or ampere to watts on the appliances they researched. (Page 240)
6. Ask students to discuss hydro boost steering used in GM vehicles. Discuss with students that hydro boost was first used in GM diesel powered vehicles. (Page 241)
7. Ask students to talk about the method used by GM to operate the HVAC system (Page 241)
8. Have students talk about belt alternator starter systems. What are the advantages of BAS systems? (Page 242)

9. Hands-on- If you have access to a vehicle with BAS system, have students identify the components of the system. (Page 242)
10. Discuss the benefits and drawbacks of a BAS system. Should a vehicle with a BAS system be considered a hybrid? Can a BAS system be added to a converted diesel vehicle to help it be considered a full hybrid vehicle? (Page 243)
11. Hands-on- If you can obtain a BAS conversion kit, have the class convert a common ICE vehicle into a mild hybrid by adding on a BAS system. This is also an opportunity for students to review safety procedures and electrical principles and develop a better understanding of hybrid vehicles. (Page 243)
12. Ask students to discuss the two-mode hybrid technology. What are its strengths and weaknesses? (Page 244)
13. Discuss with the students that Chrysler canceled production of its hybrid vehicles in 2009 because of financial troubles. (Page 244)
14. Ask students to discuss figure 15-13 as a class. Is the power flow any different than a conventional automatic transmission? (Page 245)
15. Ask students to talk about figure 15-18 the two modes system charges the batteries and propels the vehicle. (Page 246)
16. Ask students to talk about figure 15-19, 15-20, 15-21 the two modes system charges the batteries and propels the vehicle. (Page 247)
17. Ask students to review Dex-cool™ and what makes this coolant unique. (Page 247)
18. Ask students to discuss the 4 phases of operation in the Chevrolet Volt. (Page 248)
19. Ask students to discuss why the Chevrolet Volt needs to be plugged in to completely charge the batteries. (Page 248)
20. Ask students to discuss the greenhouse gases emitted by the power companies and the effects of possible millions of vehicles being plugged into the power grid every evening. (Page 249)
21. Discuss the purpose of the vehicle keeping the batteries at 30 to 35% SOC. (Page 249)
22. Discuss the dash readouts to the students that inform the owner of the SOC. (page 250)

## Demonstrate

1. If available show the students a GM parallel hybrid truck. Ask students to locate the features that identify the vehicle as a hybrid. (Page 238)
2. Show students a stator assembly used by GM in a parallel hybrid truck. (Page 239)
3. Hoist a GM Parallel hybrid truck and show students the location of the stator and other hybrid components. (Page 239)
4. Show the students the AC outlets in the GM parallel hybrid truck. Plug a laptop or tool into the outlet and show students their operation. (Page 240)
5. Show students the electrohydraulic power steering system. (Page 241)
6. Show students the parts of a BAS system in class. (Page 242)
7. Using a scan tool show students data available from a Saturn Vue hybrid for the engine system.
8. If available show students a BMW 7 series hybrid (2011+), Cadillac Escalade (2008+), Chevrolet Tahoe (2008+) GMC Yukon (2008+). (Page 244)
9. Show students a two-mode transmission in the classroom. (Page 245)
10. Using a scan tool show students the operation of a two mode transmission through the available scan tool data. (Page 245)
11. Show the students how using a planetary gear set can reduce the size of a starter motor. Show the students a starter motor disassembled that uses a planetary gear set. (Page 246)
12. Show student how the vehicle will remain operating during service when you follow the manufacturer's instructions. (Page 247)
13. If available show the students a home charging appliance for the Chevrolet volt. (Page 248)
14. If available show students how to plug a Chevrolet volt into the power grid for charging the batteries. (Page 249)
15. Using a scan tool show the students scan tool data available about the SOC of the batteries. (Page 250)



## Student Activities

1. MAL None

## Review Questions / Answers

1. How is the General Motors parallel hybrid truck able to supply 110 volts AC to the auxiliary power outlet? (Text page 240)

**The auxiliary power outlet (APO) system uses an inverter to change 42 volts DC to 110 volts AC.**

2. What type of hybrid vehicle is the GM PHT truck, and what are its capabilities? (Text page 238)

**The General Motors parallel hybrid truck (PHT) is a mild hybrid and is not capable of powering the vehicle using the electric motor alone.**

3. How does the electro-hydraulic power steering (EHPS) work? (Text page 241)

**The EHPS uses an electric motor powered hydraulic pump instead of a conventional engine-driven power steering pump to allow power-assisted steering during idle stop conditions.**

4. How does the Belt Alternator Starter (BAS) system work? (Text page 242)

**The BAS system uses a large alternator/starter combination that is capable of applying torque to the ICE crankshaft during periods of acceleration and starts the ICE, as well as charges the 32-volt battery during deceleration.**

5. How does the two-mode hybrid system work? (Text pages 244-247)

**The two-mode hybrid system uses two electric traction motors inside the transmission. This system is a full (strong) hybrid and it is capable of powering the vehicle from a stop using electric motor power alone.**

## CHAPTER QUIZ QUESTIONS AND ANSWERS:

1. The batteries used in the General Motors parallel hybrid truck are \_\_\_\_\_. (Text page 239)
  - a. 300-volt NiMH
  - b. Three 12-volt valve-regulated lead acid X**
  - c. 36-volt NiMH
  - d. 144-volt D-cell-size NiMH
  
2. In a General Motors parallel hybrid truck, where is the electric motor (FAS)? (Text page 239)
  - a. Attached to the crankshaft at the rear of the engine X**
  - b. Belt driven at the front of the engine
  - c. Inside the transmission assembly
  - d. At the output of the transmission
  
3. Which statement(s) is/are true about the auxiliary power outlets (APOs)? (Text pages 240-241)
  - a. Two outlets are inside the cab of the truck.
  - b. Two outlets are in the bed of the truck.
  - c. Each outlet has 110 volts AC.
  - d. All of the above X**
  
4. The General Motors mild (assist) hybrid system uses what type of motor/generator? (Text page 242)
  - a. Induction type motor located between the engine and the transmission
  - b. A belt operated motor/generator X**
  - c. A motor/generator located inside the transmission/ transaxle
  - d. A conventional but larger than normal alternator and starter
  
5. How is the high-voltage battery recharged in a Chevrolet Volt? (Text pages 242-243)

- a. **By plugging the vehicle into an electrical outlet X**
  - b. By running the engine
  - c. Can be charged using the gasoline engine or by plugging it into an outlet
  - d. By using a special high-voltage battery charger at a shop or dealer only
6. What type of batteries is used in the Saturn VUE and Chevrolet Malibu BAS hybrid? (Text page 242)
- a. 300-volt NiMH
  - b. Three 12-volt valve-regulated lead-acid
  - c. **36-volt NiMH X**
  - d. 144-volt D-cell-size NiMH
7. The Saturn VUE and Chevrolet Malibu hybrid electric vehicles (BAS) are capable of which of the following?  
(Text page 242)
- a. Idle stop
  - b. Regenerative braking
  - c. Powering the vehicle from a stop, using electric power only
  - d. **Both a and b are correct X**
8. Where are the electric motors in the two-mode hybrid vehicle? (Text page 246)
- a. Belt driven at the front of the engine
  - b. **Inside the transmission housing**
  - c. At the rear of the engine
  - d. At the rear (output shaft) of the transmission
9. The batteries used in the two-mode hybrid vehicles are \_\_\_\_\_. (Text page 246)
- a. **300-volt NiMH X**
  - b. Three 12-volt valve-regulated lead-acid

- c. 36-volt NiMH
- d. 144-volt D-cell-size NiMH

10. Two technicians are discussing the two-mode hybrid vehicle. Technician A says that the two modes are idle stop and regenerative braking. Technician B says that the trucks are full (strong) hybrids capable of operating on battery power alone. Which technician is correct? (Text page 244)

- a. Technician A only
- b. Technician B only X**
- c. Both Technicians A and B
- d. Neither Technician A nor B

## ASE / NATEF Correlation Charts

1.

### Suggestions for related instruction (web links / books / movies / etc.)

1. <http://www.youtube.com/watch?v=6yipXnQOakU>
2. <http://www.youtube.com/watch?v=6yipXnQOakU>
3. <http://www.youtube.com/watch?v=jbjtKbWZ67w>
4. <http://www.youtube.com/watch?v=NXfqS8w1Oh4>
5. <http://www.youtube.com/watch?v=HGlcCTweFYo>
6. [http://www.youtube.com/watch?v=HSEmz2YsDqA&feature=results\\_main&playnext=1&list=PL279F8126B993F41B](http://www.youtube.com/watch?v=HSEmz2YsDqA&feature=results_main&playnext=1&list=PL279F8126B993F41B)

# Chapter 16

## Fuel Cells and Advanced Technologies

### Chapter Summary

1. The chemical reaction inside a fuel cell is the opposite of electrolysis in that electricity is created when hydrogen and oxygen are allowed to combine in the fuel cell.
2. A fuel cell produces electricity and releases heat and water as the only by-products.
3. The major disadvantages of fuel cells include:
  - high cost
  - lack of hydrogen refueling stations
  - short range
  - Freezing-temperature starting problems
4. Types of fuel cells include PEM (the most commonly used), PAFC, MCFC, and SOFC.
5. Ultracapacitors are an alternative to batteries for the storage of electrical energy.
6. A gasoline-powered engine can be more efficient if it uses a homogeneous charge compression ignition (hCCI) combustion process.
7. Plug-in hybrid electric vehicles could expand the range of hybrid vehicles by operating on battery power alone.
8. The levels of charging include:
  - level 1—110–120 volts
  - level 2—210–220 volts
  - level 3—440–480 volts
9. Wind power and hydroelectric power are being used to recharge plug-in hybrids and provide electrical power for all uses, without harmful emissions.

### Key Terms

Electrolysis 253 • Energy carrier 253 • Fuel cell 253 • Fuel-cell hybrid vehicle (FCHV) 254 • Fuel-cell stack 255 • Fuel-cell vehicle (FCV) 254 • Homogeneous charge compression ignition (HCCI) 263 • Hydraulic power assist (HPA) 262 • Low-grade heat 257 • Membrane electrode assembly (MEA) 255 • Plug-in hybrid electric vehicle (PHEV) 264 • Polymer electrolyte fuel cell (PEFC) 254 • Proton exchange membrane (PEM) 254 • Specific energy 253 • Ultracapacitor 258

### Objectives

1. Explain how a fuel cell generates electricity
2. Discuss the advantages and disadvantages of fuel cells.
3. List the types of fuel cells.

4. Explain how ultracapacitors work.
5. Discuss alternative energy sources.

## Lecture Resources:

### Search the Internet

1. Have the students use the Internet to identify uses (other than automotive) of direct methanol fuel cells. Ask students to share their findings with the class. (Page 255)
2. Have the students use the Internet to research ultracapacitors. How does their cycle life compare to that of batteries. Why is the cycle life of an ultracapacity so long? Ask students to report their findings to the class. (Page 257)
3. Have the students use the Internet to research solid storage of hydrogen. What are the challenges? How is research addressing these challenges? Ask students to report their findings to the class. (Page 260)
4. Have the students use the Internet to research how most of the electricity in the United States is produced. How does electricity produced by fossil-fuel power stations affect the environmental benefits of plug-in vehicles? Ask students to report their findings to the class. (Page 263)
5. Have the students use the Internet to research manufacturers of EV charging stations. Ask students to summarize their finding and present them to the class. (Page 264)
6. Have the students use the Internet to research SAE J1772 charging stations. Ask students to summarize their finding and present them to the class. (Page 265)
7. Have the students use the Internet to research EV drag racing vehicles. Ask students to summarize their finding and present them to the class. (Page 266)

**Cross Curricular Activity: SCIENCE-** have the students research how a fuel cell generates energy. What are the chemical reaction that occurs? What is the results of the chemical reaction? Ask students to summarize their findings to share with the class. (Page 253)

**ASSESS-** Have the students explain the PEM fuel-cell process. Have them use Figure 16-1 in their explanation. Grade students on their understanding of the process. (Page 254)

**ASSESS-** Have the students explain why it is important to keep the electrolyte membrane cool in a PEM fuel cell. What can be done to control its temperature? Grade students on their understanding of heat issues in PEM fuel cells. (Page 256)

**ASSESS-** Have the students compare the benefits of electric motors with those of internal combustion engine. Grade students on their understanding of the operation of both electric motors and internal combustion engines as well as the comparison. (Page 258)

**ASSESS-** Have the students explain the functions of the PCU on an electric vehicle. Grade students on their understanding of the operation of electric vehicles as well as how the PCU functions. (Page 259)

**ASSESS-** Have the students write a report comparing hydraulic hybrid storage systems and homogeneous charge compression ignition systems. Ask them to include their opinion on which system shows the most promise. Grade students on their understanding of the system and their awareness of advantages and disadvantages. (Page 261)

**ASSESS-** Have the students explain the major design concerns that need to be addressed when developing an electric vehicle. Grade students on their understanding of the different types of electric vehicles being developed and their current limitations. (Page 262)

### **Additional Topics:**

1. <http://news.yahoo.com/wind-energy-business-selects-pr-agency-marketing-quotes-070809386.html>
2. <http://www.alternativeenergysecret.com/hydroelectric-energy.html>
3. <http://www.nedra.com/>
4. <http://www.fuelcellenergy.com/>

### **Discuss**

1. Have the students talk about fuel cell technology. As a fuel, how does hydrogen compare to fossil fuel? (Page 253)
2. Have the students compare and contrast the operation of internal combustion engine vehicles, fuel-cell hybrid vehicles, and hybrid electric vehicles. What are the advantages of powering vehicles with a fuel cell? (Page 253)

3. Have the students discuss types of fuel cells. Which type of fuel cell is best suited to automobile applications? (Page 254)
4. Have students talk about the current generated by a fuel cell. Why does a fuel cell generate direct current electricity? (Page 254)
5. Have students discuss fuel-cell stacks. How is the total voltage of a fuel-cell stack determined? (Page 255)
6. Have the students talk about the way hydrogen is stored onboard a vehicle. What are the pros and cons of methanol fuel cells? Are methanol fuel cells likely to be used in automotive applications? (Page 255)
7. Have the students discuss fuel purity in PEM fuel cells. What happens if the hydrogen steam being fed to the PEM anode is not pure? Why is this a concern for usage in vehicles? (Page 256)
8. Review with the students the purpose of having moisture in contact with the electrolyte membrane in PEM fuel cell. Use 16-9 to highlight the humidifier used in a Honda FCX fuel-cell vehicle. What is the purpose of the humidifier? (Page 256)
9. **Environment-** Have the students talk about carbon-neutral fuels. Do we have enough carbon-neutral fuels to power vehicles? (Page 257)
10. Have the students discuss waste heat and low-grade heat. How do the conditions of low-grade heat affect heat transfer? How is the heat generated by fuel cells dealt with in an FCHV? (page 257)
11. Have the students discuss hybridization of fuel-cell vehicles. What is the purpose of an electrical storage device in a hybrid vehicle? (Page 258)
12. Have the students talk about secondary batteries and ultracapacitors. Why are ultracapacitors suited to electric assist applications in fuel-cell hybrid vehicles? (Page 258)
13. Have the students discuss the advantages and disadvantages of ultracapacitors in current use. What is the major downside of ultracapacitors? (Page 259)
14. Have the students talk about electric traction motors. Why is the typical drive motor used in FCHVs and HEVs so reliable? (Page 259)
15. Have the students discuss transaxles used in fuel-cell hybrid vehicles. How do these transaxles compare to the transmissions required for vehicles powered by internal combustion engines? (Page 260)



16. Have the students talk about power control units in fuel-cell hybrid vehicles. Why does an FCHV need an inverter? What are the other functions of the PCU? (Page 260)
17. Have the students review and discuss regenerative braking systems. How does the electric drive motor function during regenerative braking? (Page 261)
18. Have the students discuss the issue of hydrogen storage in fuel-cell hybrid vehicles. Review physical density with students. How does physical density affect hydrogen storage capacity? (Page 261)
19. Have the students discuss how compressed hydrogen gas is stored and how tanks are rated. How does the use of multiple small storage tanks further reduce hydrogen storage capacity on fuel-cell vehicles? (Page 262)
20. Have the students discuss liquid hydrogen and its properties and requirements. How does the energy content of liquid hydrogen compare to that of gasoline? (Page 262)
21. Have the students review hydrogen gas, liquid hydrogen, and solid storage of hydrogen. What advantages as a fuel does hydrogen have over hydrocarbons? (Page 263)
22. Have the students discuss how a hydraulic hybrid storage system works. What are the potential problems with the system? (Page 263)
23. Have the students talk about the homogeneous charge compression ignition process. Have them use Figure 16-27 to compare the HCCI system to diesel and gasoline engines. What are the current downsides to the HCCI system? (page 264)
24. Have the students discuss plug-in hybrid electric vehicles. What is the main advantage of PHEVs? How can these plug-in hybrids achieve zero emissions? (Page 264)
25. Have the students talk about the factors affecting the future of electric vehicles. How is the rising cost of fossil fuels affecting consumers' ability to continue with ICE vehicles? How might this factor spur the development of EVs? (Page 265)
26. Have the students discuss weather concerns for electric vehicles. How do both cold and hot weather affect electrical power needs for electric vehicles? (Page 265)

27. Have the students talk about electric vehicle range, charging, and recharging. What are factors that affect an EV's range? How has California addressed the range of EVs/ (Page 266)
28. Have students discuss wind power. How is electricity generated from wind power? What are its advantages? Why can't wind farms be placed in more locations? (Page 267)
29. Have the students talk about hydroelectric power generated? What is the advantage of hydroelectric power over wind power? (Page 267)
30. Have the students discuss drag racing for electric-powered vehicles. How is the power of the electric powered vehicles increased? What are NEDRA's reasons for promoting electric drag racing? (Page 268)

## **Demonstrate**

1. If available take students to a wind farm and show them how a wind power unit works. (Page 266)

## **Student Activities**

1. MAL Chapter 91 Power Point (Page 255)
2. MAL Section X Crossword Hybrid Terms
3. MAL Chapter 91.2 Animation Identifying Engine Types
4. MAL Shop Assessment Stop Safely Now Warning Light Concern
5. MAL Shop Assessment Squeaking Noise from Engine Compartment Concern
6. MAL Shop Assessment Vehicle Vibrates When Brakes Applied Concern
7. MAL Shop Assessment Poor AC Performance During Acceleration at Slow Speeds Concern
8. MAL Shop Assessment Intermittent Check Engine Light Concern
9. MAL Chapter 91 NATEF Task Sheet Hybrid HV Circuit Disconnect
10. MAL Chapter 91 NATEF Task Sheet Identifying HV of Hybrid Electric Vehicles
11. MAL Chapter 91 NATEF Task Sheet Hybrid Engine Service Precautions
12. MAL Chapter 91 NATEF Task Sheet Hybrid AC System Electrical Circuits

## 13. MAL Chapter 91 NATEF Task Sheet Electric/Fuel cell Vehicle Identification

### Review Questions / Answers

1 How does a fuel cell work? (Text pages 254-255)

**A fuel cell generates electricity by harnessing the energy that is released when hydrogen combines with oxygen. Hydrogen is fed to one side of a catalyst-coated membrane, while oxygen is fed to the other side. The proton from the hydrogen is allowed to pass through the membrane, but the electron must follow a path external to the fuel cell to combine with the oxygen on the opposite side. This electron flow is converted into usable power by sending it through an electrical load such as a motor.**

2. What are the advantages and disadvantages of fuel cells? (Text page 254)

**The advantages of a fuel cell include zero emissions (only water and heat), high efficiency relative to an internal combustion engine, and no moving parts. The disadvantages of a fuel cell include high cost, lack of refueling infrastructure, perceived safety issues, lack of vehicle range, lack of durability, freeze starting problems, and insufficient power density.**

3. What are the uses of the various types of fuel cells? (Text page 255)

**Uses of the various types of fuel cells include:**

**PAFC (Phosphoric Acid Fuel Cell)** – used for stationary power applications

**PEM (Proton Exchange Membrane Fuel Cell)** – used in vehicles, portable power, small stationary power

**MCFC (Molten Carbonate Fuel Cell)** – used in industrial and institutional power

**SOFC (Solid Oxide Fuel Cell)** – used in stationary power and military vehicle applications

**DMFC (Direct Methanol Fuel Cell)** – used in small portable power applications

4. How does an ultra-capacitor work? (Text page 258)

**Ultra capacitors can be used in hybrid-electric vehicle applications to store electrical energy during regenerative braking, and then discharge that energy as the vehicle accelerates. Ultra capacitors**

**lack energy density, but can charge and discharge very rapidly and are sometimes used in place of the battery pack in fuel cell hybrid vehicle designs.**

5. What are the advantages and disadvantages of using hydrogen? (Text pages 260-262)

**Advantages of using hydrogen include zero emissions, quiet operation, and ability to generate hydrogen using renewable energy sources. Disadvantages of using hydrogen include limited vehicle range, perceived safety issues, a lack of fueling infrastructure, and low well-to-tank efficiency.**

6. What alternative power sources could be used for vehicles use? (Text pages 267-268)

**Alternative power sources that could be harnessed for vehicle use include hydroelectricity and wind power.**

#### **CHAPTER QUIZ QUESTIONS AND ANSWERS:**

1. A fuel cell produces electricity from \_\_\_\_\_ and \_\_\_\_\_. (Text page 253)

- a. Gasoline/oxygen
- b. Nitrogen/hydrogen
- c. Hydrogen/oxygen X**
- d. Water/oxygen

2. What are the by-products (emissions) from a fuel cell? (Text page 253)

- a. Water X**
- b. CO<sub>2</sub>
- c. CO
- d. Non-methane hydrocarbon

3. Which type of fuel cell is the most likely to be used to power vehicles? (Text page 254)

- a. PAFC
- b. PEM X**
- c. MCFC
- d. SOFC

4. Which liquid fuel could be used to directly power a fuel cell? (Text page 256)

- a. Methanol X**
- b. Ethanol
- c. Biodiesel
- d. Unleaded gasoline

5. Which is *not* a function of an ultra-capacitor? (Text page 258)

- a. Can pass AC current
- b. Can be charged with DC current
- c. Discharges DC current
- d. Can pass DC current X**

6. Hydrogen is commonly stored at what pressure? (Text page 261)

- a. 100,000 psi
- b. 50,000 psi
- c. 5,000 psi X**
- d. 1,000 psi

7. Hydrogen storage tanks are usually constructed from \_\_\_\_\_. (Text page 261)

- a. Steel
- b. Aluminum
- c. Carbon fiber

**d. Both b and c X**

8. HCII is a process that eliminates what parts or components in a gasoline engine? (Text page 263)

a. Fuel tank

b. Battery

c. Fuel injectors

**d. Ignition system X**

9. A plug-in hybrid is different from a conventional hybrid electric vehicle because it has \_\_\_\_\_.

(Text page 264)

a. A built-in battery charger

b. Li Ox batteries

**c. More batteries X**

d. Bigger motor/generator

10. Which energy source(s) is (are) currently being used to help reduce the use of fossil fuels? (Text pages

267-268)

a. Hydrogen

b. Wind power

c. Hydroelectric power

**d. Both b and c X**

## **ASE / NATEF Correlation Charts**

1.

### **Suggestions for related instruction (web links / books / movies / etc.)**

1. <http://www.youtube.com/watch?v=GujZznGtphI>

2. <http://www.youtube.com/watch?v=XfOtdzY3STQ>
3. [http://www.youtube.com/watch?v= MsG9REFN3s](http://www.youtube.com/watch?v=MsG9REFN3s)
4. <http://www.youtube.com/watch?v=8rofx6Gaz40>
5. <http://www.youtube.com/watch?v=k-2Jau1rtIU>

# Chapter 17

## Hybrid Safety and Service Procedures

### Chapter Summary

1. Personal protective equipment (PPE) for work on hybrid electric vehicles includes the wearing of high-voltage rubber gloves rated at 1,000 volts or more worn with outer leather gloves to help protect the rubber gloves.
2. A digital meter that meets CAT III standards should be used when working around the high-voltage section of a hybrid electric vehicle.
3. Safety glasses and face shield should be worn whenever working around the high-voltage circuits of a hybrid electric vehicle.
4. The high-voltage system can be shut off at the battery pack by simply being certain that the ignition is off. Disconnecting the 12-volt battery is additional security that the high-voltage circuits are de-powered.
5. When servicing a hybrid electric vehicle, always observe safety procedures.

### Key Terms

ANSI \*270 ASTM \*270 CAT III \*238 DMM \*238 Floating ground \*274 HV \*237

HV Cable \*237 IEC \*271 Linesman's gloves \*237 NiMH \*277 OSHA \*237 Service plug \*274

### Objectives

1. Safety de-power a hybrid electric vehicle. (Page274)
2. Safety perform high-voltage disconnects. (Page 274)
3. Understand the unique service issues related to HEV high-voltage systems. (Page 278)
4. Correctly use appropriate personal protective equipment (PPE) (Page 270)
5. Perform routine vehicle service procedure on a hybrid electric vehicle. (Page 272)
6. Explain hazards while driving, moving, and hoisting a hybrid electric vehicle. (Pages 275-277)



## Lecture Resources:

### Search the Internet

1. Have the students use the Internet to research high voltage. What is classified as “high voltage”? What voltage levels are dangerous? Have students report their findings to the class. (Page 270)
2. Have the students use the Internet to research ASTM Standard F496. What is the organization that sets this standard? What is the recommended sequence of testing gloves? Ask students to report their findings to the class. (Page 238)
3. Have the students use the Internet to research ANSI Z87.1. What is the organization that sets this standard? Why is sideshield coverage important? Ask students to report their findings to the class. (Page 272)
4. Have the students use the Internet to research hybrid safety. What kinds of lights and indicators inside the vehicle typically show that power is on? What kind of temperature limitations does a battery pack have? Ask students to share their findings with the class. (Page 273)
5. Have the students use the Internet to research disposal methods for NiMH batteries. What method of disposal do most manufacturers recommend for batteries from HEVs? Have students compare their findings. (Page 276)
6. Have students use the repair information system to research the de-power of several hybrid electric vehicles. Have student compare the procedures and write a report on similarities and differences. Ask the student to share their finding with the class. (Page 277)
7. Have the students use the Internet to find manufacturers and distributors of 0W-20 oil. What is the cost? Does this oil require a special oil filter? Have students create a summary of information for 0W-20 oil, include cost comparisons, to share with the class. (Page 278)
8. Have students use the repair information system to look up TSBs for servicing hybrid electric vehicles. Have student pick a TSB to share with the class. (Page 279)
9. Have the students use the Internet to research the cost of safety gloves. Remind them to be sure the gloves meet safety standards. Have them share their findings with the class. (Page 280)

**ASSESS-** Have the students describe safety precautions that should be taken to work on HRVs. Grade them on thoroughness and a clear understanding of the dangers that hybrid present and how those dangers can be addressed. (Page 274)

**Cross-Curricular Activity: Science-**Have the students research nickel-metal hydride batteries. How do these batteries compare to other types of batteries? Why are hybrid manufacturers moving toward lithium batteries? Ask students to report their findings to the class. (Page 275)

**ASSESS-** Have the students describe auxiliary battery testing and service. Grade students on their understanding of the auxiliary battery on a hybrid electric vehicle and their awareness of considerations for this type of battery. (Page 279)

**Cross-Curricular Activity: Science** Have the students research rubber. What are its chemical properties? Why is petroleum a solvent for rubber? Have students summarize their findings and present them to the class. (Page 281)

#### **Additional Topics:**

1. [http://en.wikipedia.org/wiki/High\\_voltage\\_cable](http://en.wikipedia.org/wiki/High_voltage_cable)
2. <http://www.ni.com/white-paper/5019/en>
3. <http://firstaid.webmd.com/electric-shock-treatment>
4. <http://www.autoinc.org/archives/2006/june2006/collision.htm>
5. <http://www.hybridcars.com/gas-mileage-factors/low-resistance-tires.html>

#### **Discuss**

1. Have the students discuss the identifying colors used for high-voltage cables. What does blue or yellow mean? What does orange plastic conduit mean?
2. Have the students talk about the importance of using leather gloves over insulated gloves. Remind them that when purchasing leather gloves, they must be large enough to fit over the insulated safety gloves. What should be done before each use of gloves? (Page 238)
3. **Hands-On-** Have the students wear insulated and leather gloves while trying to take a voltage reading using a CAT II multimeter. Ask students to share their experience with the task. (Page 238)

4. Have the students discuss CAT II-rated digital multimeters. Why is a CAT II-Certified DMM required for taking measurements on hybrid electric vehicles? (Page 238)
5. Have the students talk about the difference among CAT II, III and IV meters. What determines a CAT rating? Point out that electrical leads for a hybrid electric vehicle should also be CAT II rated and that they should not be assumed to be CAT II just because it is a CAT II meter-it is common for technicians to interchange leads between meters. (Page 272)
6. Have the students discuss insulation testers. When is an electric insulation tester used? (Page 272)
7. **SAFETY-** Why do some manufacturers recommend full face shield instead of safety glasses when working on hybrid electric vehicles? What greater benefit does a face shield offer? (Page 272)
8. **TIP-** Use a cooking timer with a bell alarm or some other audible signal as a way to know when the 10-minute wait period for HV battery shutdown has passed. (Page 273)
9. Have the students talk about when a high-voltage system needs to be de-powered and when it doesn't. When servicing a system that may contain high voltage, how can you be sure of whether or not it needs to be de-powered? (Page 274)
10. **Hands-On-** Review with the students the importance of separating the key from a hybrid vehicle to prevent an accidental start-up that could lead to injury. Have students create a metal lock box or research the cost of purchasing one. (Page 275)
11. **SAFETY-** gather the materials necessary for the students to create a "high voltage –Do not touch" sign that can be placed on the roof of a hybrid vehicle that is being stored. (Page 275)
12. Have the students talk about storage of NiMH batteries. How long can a high-voltage battery be stored? After powering up again, what is required to reset the MIL? (Page 276)
13. Have the students discuss oil changes for HEVs. Why do most hybrid electric vehicles require either SAE 0W-20 or SAE 5W-20? (Page 277)
14. Have the students review the eight-step diagnostic procedure. Is diagnosing a hybrid different from diagnosing any other type of vehicle? (Page 278)

15. Have the students talk about cooling system service for HRVs. What considerations for servicing an HEV cooling system may differ from those for servicing an ICE cooling system? (Page 278)
16. Have the students discuss servicing the air-conditioning of an HEV. What does the service technician need to know about the air-conditioning compressor on a hybrid electric vehicle? (Page 279)
17. Have the students talk about regenerative braking system and base brakes used on hybrid electric cars. Why do the base brakes on HEVs often get stuck or function incorrectly? (Page 279)
18. Have the students discuss rolling resistance. How does replacing tires affect fuel economy? (Page 279)
19. Have students talk about auxiliary battery service. What is the proper charger to use when recharging an AGM battery? Can this charger also be used on a regular lead acid battery? (Page 279)
20. Have the students discuss the storage and care of safety gloves. What kinds of materials are products can damage rubber gloves? (Page 280)
21. Have the students talk about wearing HV gloves. What is the purpose of leather protectors? Why is glove powder used? (Page 281)

## **Demonstrate**

1. Have the students talk about the need for safety precautions when working around and with hybrid electric vehicles. Both hybrid electric and all-electric vehicles use high-voltage circuits that cannot be touched without protection. (Page 270)
2. Using a CAT III multimeter, show the students how to check a floating ground to identify a high-voltage leak. (Page 273)
3. Show the students the de-power procedure on a hybrid vehicle. Supervise students as they de-power the vehicle. (Page 274)
4. Show the students jump starting procedures on a hybrid vehicle. Review safety procedures for connecting and disconnecting jumper cables. Can a jump box or jumper cable from another vehicle be used on a high-voltage HV battery pack? (Page 274)
5. Show the students the procedure for moving and storing a hybrid vehicle that is waiting for parts to arrive. (Page 275)

6. Have students identify lift points for a hybrid vehicle that you have in the shop. Using a floor jack/lift, raise the vehicle and have the students take note of areas of concern on the vehicle. (Page 277)
7. Show the students how to inspect, test, and store HV safety gloves and leather protectors. (Page 280)
8. Show the students how to tighten the strap on the back of leather protectors. (Page 281)

## Student Activities

1. MAL Chapter 90 Power Point (Page 270)
2. MAL Chapter 89.3 Activity Label HEV components
3. MAL Chapter 89.3 Activity Label HEV1 components
4. MAL Chapter 90.4 Activity Jump start a hybrid vehicle
5. MAL Chapter 90.4 Crossword hybrid terms

## Review Questions / Answers

1. What are the recommended items that should be used when working with the high-voltage circuits of a hybrid electric vehicle? (Text pages 270-272)  
**Most hybrid electric vehicle manufacturers recommend the wearing of high-voltage (1,000 volts) linesman's gloves with protective leather gloves over them. Some vehicle manufacturers recommend wearing a face shield.**
2. What actions are needed to disable the high-voltage (HV) circuit? (Text page 274)  
**The actions needed to disable the high-voltage circuits vary according to the exact make and model of vehicle, but usually include:**
  - a. Turn the ignition off and remove the key
  - b. Remove high-voltage control fuses
  - c. Remove high-voltage service plug
  - d. Disconnect the 12-volt auxiliary battery

3. What are the precautions that service technicians should adhere to when servicing hybrid electric vehicles?  
(Text pages 277- 279)

**The service technician can perform routine service without having to disable the high-voltage circuits. However, if service work is to be performed on a system or component that has high voltage, follow the specified de-powering procedures before service work starts and wear protective high-voltage linesman's gloves.**

#### CHAPTER QUIZ QUESTIONS AND ANSWERS:

1. Rubber gloves should be worn whenever working on or near the high-voltage circuits or components of a hybrid electric vehicle. Technician A says that the rubber gloves should be rated at 1,000 volts or higher. Technician B says that leather gloves should be worn over the high-voltage rubber gloves. Which technician is correct? (Text page 270)

- a. Technician A only
- b. Technician B only
- c. Both Technicians A and B    X**
- d. Neither Technician A nor B

2. A CAT III-certified DMM should be used whenever measuring high-voltage circuits or components. The CAT III rating relates to \_\_\_\_\_. (Text page 271)

- a. High voltage
- b. High energy
- c. High electrical resistance
- d. Both a and b    X**

3. All of the following will shut off the high voltage to components and circuits, *except* \_\_\_\_\_. (Text page 274)

- a. Opening the driver's door    X**
- b. Turning the ignition off

- c. Disconnecting the 12-volt auxiliary battery
  - d. Removing the main fuse, relay, or HV plug
4. If the engine is not running, Technician A says that the high-voltage circuits are de-powered. Technician B says that all high-voltage wiring is orange-color. Which technician is correct? (Text pages 270; 273)
- a. Technician A only
  - b. Technician B only X**
  - c. Both Technicians A and B
  - d. Neither Technician A nor B
5. Which statement is *false* about high-voltage wiring? (Text page 273)
- a. Connects the battery pack to the electric controller
  - b. Connects the controller to the motor/generator
  - c. Is electrically grounded to the frame (body) of the vehicle X**
  - d. Is controlled by a relay that opens if the ignition is off
6. What routine service procedure could result in lower fuel economy, which the owner may discover? (Text pages 277; 279)
- a. Using the wrong viscosity engine oil
  - b. Replacing tires
  - c. Replacing the air filter
  - d. Either a or b X**
7. Two technicians are discussing jump starting a hybrid electric vehicle. Technician A says that the high-voltage (HV) batteries can be jumped on some HEV models. Technician B says that the 12-volt auxiliary battery can be jumped using a conventional jump box or jumper cable. Which technician is correct? (Text page 274)
- a. Technician A only

- b. Technician B only
  - c. Both Technicians A and B    X**
  - d. Neither Technician A nor B
8. What can occur if a hybrid electric vehicle is pushed in the shop? (Text page 275)
- a. The HV battery pack can be damaged
  - b. The tires will be locked unless the ignition is on
  - c. Damage to the electronic controller can occur
  - d. High voltage will be generated by the motor/generator    X**
9. Nickel metal hydride (NiMH) batteries can be damaged if exposed to temperatures higher than about \_\_\_\_\_. (Text page 275)
- a. 150°F (66°C)    X**
  - b. 175°F (79°C)
  - c. 200°F (93°C)
  - d. 225°F (107°C)
10. How should nickel metal hydride (NiMH) batteries be disposed of? (Text page 276)
- a. In regular trash
  - b. Call an 800 number shown under the hood of the vehicle for information    X**
  - c. Submerged in water and then disposed of in regular trash
  - d. Burned at an EPA-certified plant

## ASE / NATEF Correlation Charts

17.

### Suggestions for related instruction (web links / books / movies / etc.)

1. <http://www.youtube.com/watch?v=DtR2zH5-7d0>
2. [http://www.youtube.com/watch?v=fj1j7Ot3\\_48](http://www.youtube.com/watch?v=fj1j7Ot3_48)



3. [http://www.youtube.com/watch?v=sbLG2kk4qcM&feature=results\\_main&playnext=1&list=PL0ECCC5227311A3F1](http://www.youtube.com/watch?v=sbLG2kk4qcM&feature=results_main&playnext=1&list=PL0ECCC5227311A3F1)

# Chapter 18

## First Responder Procedures

### Chapter Summary

1. Any incident involving a hybrid electric or alternative-fuel vehicle should be treated following standard operating procedures (SOP).
2. Identification of the hybrid electric vehicle includes:
  - emblems
  - orange cables
3. The wiring conduit colors and their meaning include:
  - Black—12 volts
  - red—12 volts
  - Yellow—42 volts
  - Blue—42 volts
  - orange—144 to 600 volts or higher
4. To de-power the high-voltage system, the 12-volt auxiliary battery must be disconnected. Use the double cut method for best results.
5. Cut lines are often marked on the 12-volt battery cable to indicate where they should be cut to disable the 12-volt system, which in turn de-powers the high-voltage system.
6. The location of the high-voltage battery and 12-volt battery can vary according to make, model, and year of vehicle. High-voltage batteries are located at the rear either under or behind the rear seat. The 12-volt auxiliary battery can be located either under the hood or in the trunk area.
7. The steps involved in the event of an incident with a hybrid electric vehicle include:
  - Step 1—Identify the vehicle.
  - Step 2—Disable the vehicle.
  - Step 3—Stabilize the vehicle.
  - Step 4—Access the occupants.
  - Step 5—Turn off the ignition.
  - Step 6— Disconnect or cut the 12-volt battery cables.
8. In the event of a fire with a hybrid electric vehicle, follow standard operating procedures.
9. Most hybrid electric vehicles do not create any hazardous materials that are not commonly found in any other incident involving conventional vehicles.
10. Treat any vehicle using alternative fuels as a normal incident and yet extra water should be directed to keep flames from getting to storage tanks (LPG or CNG).

### Key Terms

Lines 288 • Double cut method 288 • Hazmat 289 • Hot stick 285 • Incident 283 • International Fire service training Association (IFSTA) 288 • National Fire Academy (NFA) 288 • National Fire Protection Association (NFPA) 288 • Personal protective equipment (PPE) 283 • Standard operating guidelines (SOG) 283 • Standard operating procedures (SOP) 283

## Objectives

1. Follow first responder standard operating procedures.
2. Identify a hybrid electric vehicle.
3. Safely de-power a hybrid electric vehicle.
4. Safely handle spills from a hybrid electric vehicle
5. Discuss first responder issues involving alternative-fuel vehicles.

## Lecture Resources:

Search the Internet

1. Have students use the Internet to research accidents involving hybrid electric vehicles. What is the national average? Ask students to share their findings with the class. (Page 283)
2. Have students use the Internet to research tools specifically made for high voltage handling. Ask students to summarize their findings into a report to share with the class. (Page 285)
3. Have the students use the Internet to research the history of seatbelts. How have safety belts changed over the years? Ask students to share their findings with the class. (Page 286)
4. Have students use the Internet to research the history of Airbags. When were they first used? How have they evolved? How have they affected automobile accidents fatality statistics? Have students present their findings to the class. (Page 287)
5. Have the students use the Internet to research National Fire Academy. How many courses are offered for hybrid vehicle emergency response? Ask students to share their findings with the class. (Page 288)

**ASSESS-** Have students list all the identifications used by hybrid vehicle manufacturers to identify the hybrid electric vehicles. Grade the students on detail and indicating that the vehicles have some several types of identification to identify the vehicle as a hybrid. (Page 284)

**ASSESS-** Ask students to form emergency response teams. Have students respond to a staged hybrid vehicle accident in the shop. Grade students on how well they work together and follow SOPs for the accident. (Page 289)

### **Additional Topics:**

1. [http://en.wikipedia.org/wiki/Incident\\_Command\\_System](http://en.wikipedia.org/wiki/Incident_Command_System)
2. <http://www.fema.gov/>

### **Discuss**

1. Ask students to discuss what makes a vehicle accident a hazardous material accident response. (Page 283)
2. Discuss with students the emergency response guidebook available for purchase by First responders or emergency response agencies. (Page 283)
3. Review PPE with students and discuss this equipment with them. (Page 283)
4. Using the Figure 18-1 discuss the design of the tools pictured (Page 283)
5. Ask students to discuss as a class hybrid identification and what to look for to establish the vehicle is a hybrid. (Page 284)
6. Have students discuss the different locations of hybrid batteries. What are the advantages or disadvantages of these locations? (Page 284)
7. Discuss wire colors with students and what type of voltage is present by wire color. (Page 285)
8. Ask students to discuss why fiberglass is nonconductive. What other materials are nonconductive that could be used? (Page 285)
9. Have students discuss the different types of retractors used in automobiles. What types of retractors are used for safety belts? (Page 286)
10. Have students discuss the advantages of having a car equipped with a pretensioner. What safety concerns are associated with a pretensioner? (Page 286)
11. Have students discuss why airbags are considered supplemental. What safety feature do they supplement? (Page 287)

12. SAFET- Discuss the dangers associated with working around seat belt pretensioner. (Page 287)
13. Ask the students as a class to discuss SOP's for a hybrid vehicle accident. Ask students why these SOPs should be followed in every hybrid accident. (Page 288)
14. Ask students to discuss the difference between an offensive fire attack and a defensive fire attack. (Page 289)
15. Discuss with students that any signs of battery damage or leakage turns the accident scene into a hazardous emergency response. (Page 289)

## **Demonstrate**

1. Show students a Emergency response guidebook to order a book [www.jjkeller.com](http://www.jjkeller.com) (Page 283)
2. If available have the local emergency service show students emergency response equipment, SCBA, Bunker gear etc. (Page 283)
3. Show students the fuse and relay locations of a hybrid electric vehicle. (Page 284)
4. Show students the location of different types of wire colors and their routing in a hybrid electric vehicle. (Page 285)
5. Show students different types of seat belt locking mechanisms and how they worked. (Page 286)
6. Show students different types of airbag inflation systems. Demonstrate and explain how to differentiate between the systems. (Page 287)
7. Show students cables with dotted lines for emergency response people to locate were to cut cables. (Page 288)

## **Student Activities**

1. None MAL

## Review Questions / Answers

1. . What is the meaning of the various colors of wiring? (Text page 285)

**Black or red means 12 volts**

**Yellow or blue indicates 42 volts**

**Orange means 144+ volts (shock hazard)**

2. What steps should be followed when dealing with an incident involving a hybrid electric vehicle? (Text page 288)

**STEP 1 Identify the vehicle as soon as possible to determine if it is a hybrid electric vehicle.**

**STEP 2 Disable the vehicle by:**

- Remove the ignition key or fob.
- Move the key or fob at least 15 feet away from vehicle in case it is a smart key that can keep the vehicle powered up if near the vehicle.
- Verify that the "READY" light is off (if equipped).
- Place the transmission in PARK or Neutral.
- Approach the vehicle from the side; avoid walking in the front or rear of the vehicle if possible.

**STEP 3 Stabilize the vehicle. Chock the wheels and set the parking brake if possible.**

**STEP 4 Access the occupants. Use normal removal procedures as required such as:**

- Pull steering column forward and away from the occupant.
- Cut front pillar.
- Remove (peel) the roof.
- Door removal/displacement. Doors can be removed by conventional rescue devices such as hand, electric, and hydraulic tools.
- Dashboard displacement.
- Rescue lift airbags. Responders should not place cribbing or rescue lift airbags under the high-voltage power cables, exhaust system, or fuel system.

**STEP 5 Turn the ignition off. Turning the ignition off and moving the key or key fob away from the vehicle will disable the high-voltage system.**

**STEP 6 Disconnect or cut the 12-volt battery cables.**

3. How should a fire involving an alternative-fuel vehicle be handled? (Text page 289)

**It is often impossible for first responders to be able to identify a vehicle as being powered by an alternative fuel besides gasoline. When approaching any vehicle incident, the standard operating procedures should be followed and proceed to save human life first and property second.**

#### **CHAPTER QUIZ QUESTIONS AND ANSWERS:**

1. What is the highest priority when following standard operating procedures? (Text page 283)

- a. **Save or protect human life X**
- b. Protect vehicle from damage
- c. Extinguish the fire
- d. Rescue animals

2. What personal protective equipment (PPE) should be used when responding to an incident that could involve a hybrid electric vehicle? (Text page 283)
- a. Helmet with face shield
  - b. Self contained breathing apparatus (SCBA)
  - c. High-voltage linesman's gloves
  - d. All of the above X**
3. How would a first responder be able to identify a hybrid electric vehicle? (Text page 284)
- a. Emblems on the front, side, or rear of the vehicle
  - b. Orange-colored cables
  - c. Blue-colored cables
  - d. All of the above X**
4. A fire involving a hybrid electric vehicle should be extinguished using \_\_\_\_\_. (Text page 288)
- a. Water or a fire extinguisher X**
  - b. Large amounts of water only
  - c. Dry chemical fire extinguisher only
  - d. CO2 fire extinguisher only
5. What is the color of the cables for the 12-volt auxiliary battery? (Text page 285)
- a. Blue
  - b. Yellow
  - c. Red or black X**
  - d. Orange
6. What color wires or cable represent a shock hazard? (Text page 285)
- a. Yellow
  - b. Red or black



- c. **Orange X**
  - d. Blue
7. The 12-volt auxiliary battery is located where? (Text pages 286-287)
- a. Under the hood
  - b. Under the second-row seat
  - c. In the trunk
  - d. **Either a or c X**
8. Why should 12-volt battery cables be double cut? (Text page 288)
- a. **To prevent the possibility of the cut ends from coming in contact X**
  - b. To prevent the high voltage from arcing
  - c. To be sure the circuit has been cut
  - d. All of the above
9. If the electrolyte from a high-voltage battery is spilled, what should be used to neutralize it? (Text page 289)
- a. Baking soda
  - b. **Vinegar or boric acid X**
  - c. Water
  - d. CO<sub>2</sub>
10. Which alternative fuel burns with an invisible flame? (Text page 289)
- a. Ethanol (E85)
  - b. Propane
  - c. **Methanol X**
  - d. CNG

## ASE / NATEF Correlation Charts

1.

**Suggestions for related instruction (web links / books / movies / etc.)**

1. <http://www.youtube.com/watch?v=WzdRdFclcmo>
2. <http://www.youtube.com/watch?v=SA3JF2FLUTw>
3. <http://www.youtube.com/watch?v=1d3ljUtl6kl>
4. <http://www.youtube.com/watch?v=33Xnbze2t8g>

# Introduction to the Chevrolet Volt Interlock System



# High voltage interlock system saved their lives!



# High Voltage Component Location

2011 Chevrolet Volt

Fig. 1: Hybrid Control Electronic Components  
Courtesy of GENERAL MOTORS CORP.

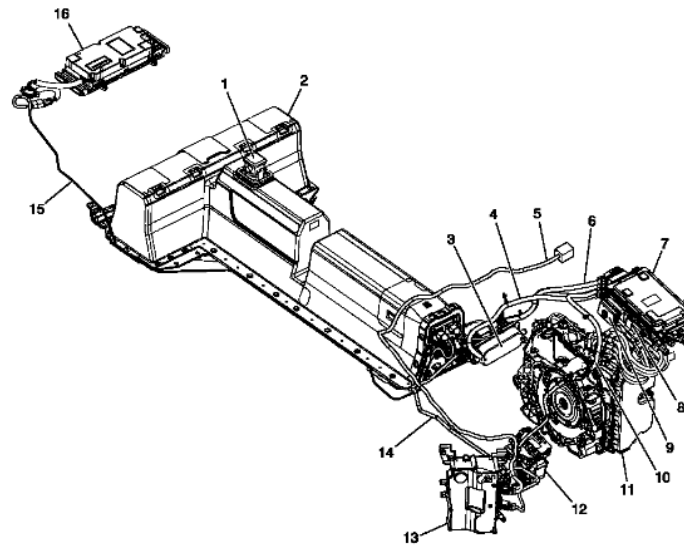



# Inverter Interlock





# Inverter Interlock





# Battery Charger Interlock Wiring Diagram

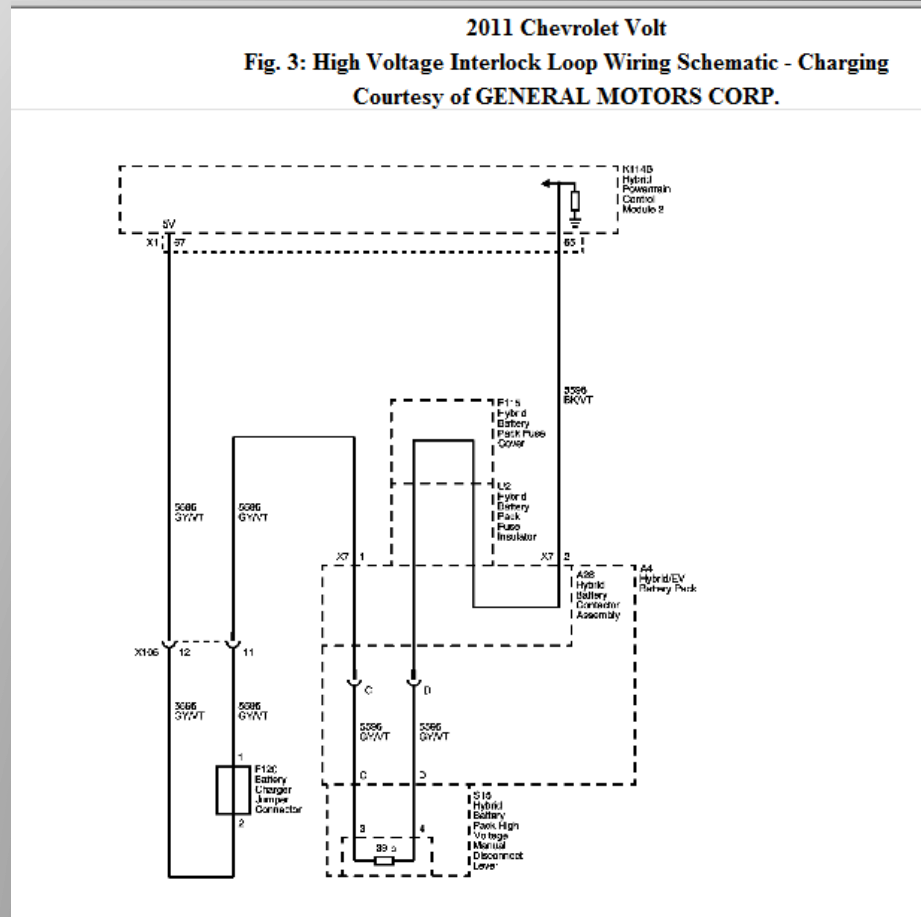

# Battery Charger Interlock



# DC to DC Converter Interlock



# High Voltage Battery Interlock

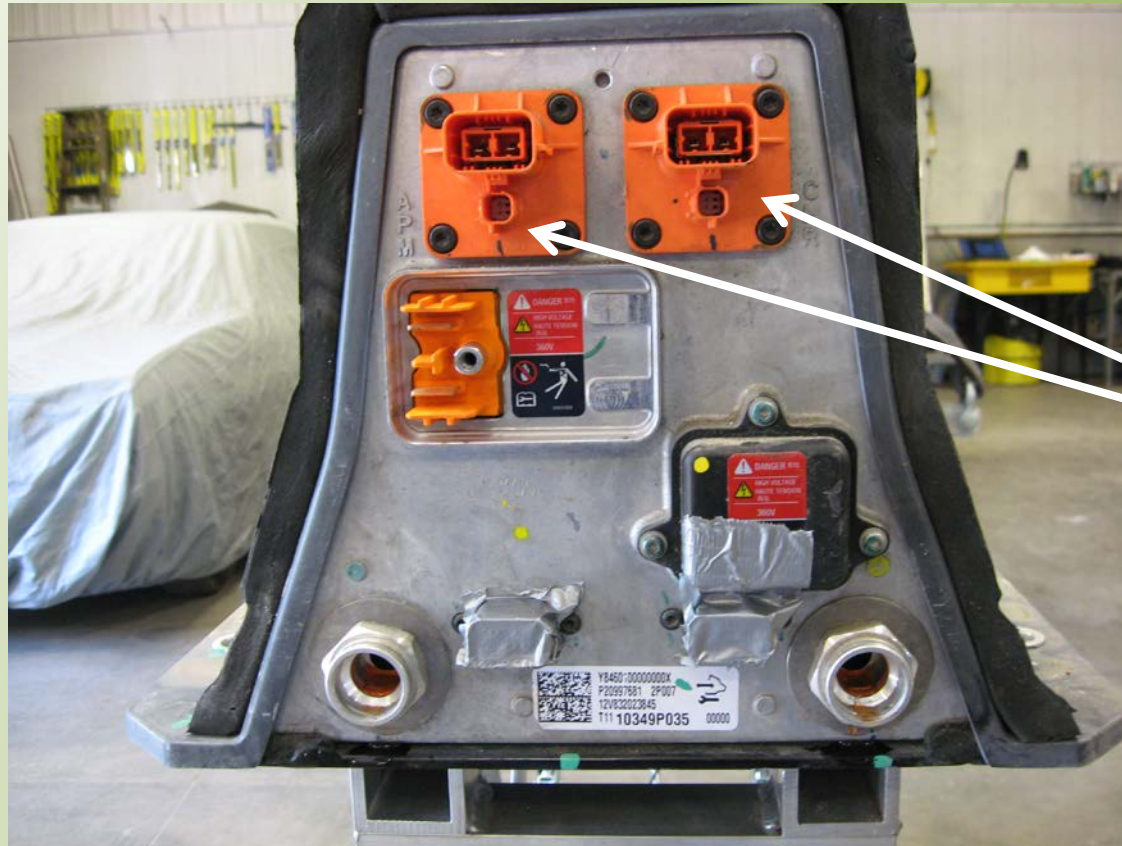

Interlock connector



# High Voltage Battery Interlock

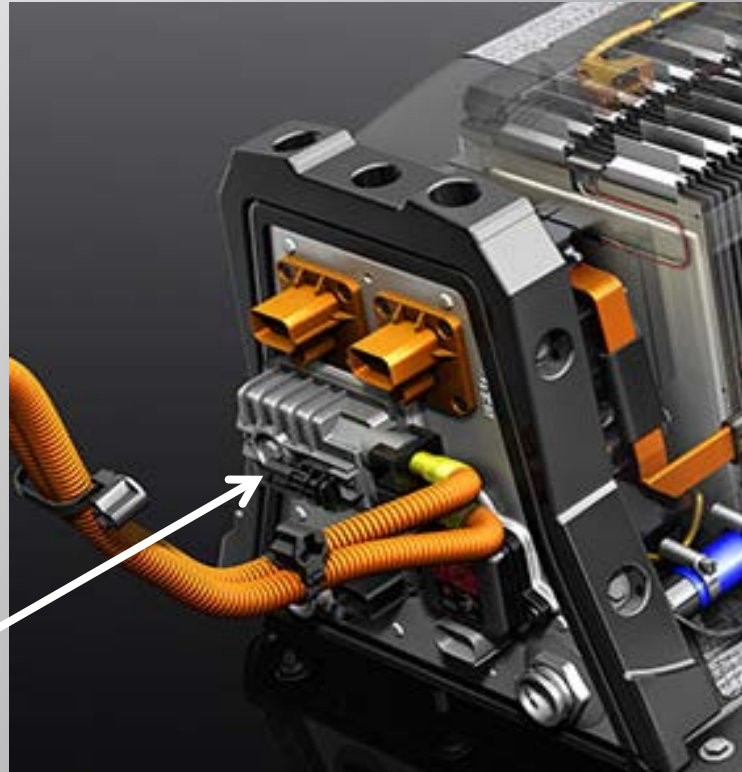

Interlock



FLUKE 1587 INSULATION MULTIMETER

379.7 V DC

LOCK HOLD MINMAX Hz RANGE Test Voltage °C °F

INSULATION TEST

mV mA 50V 1000V INSULATION

V Ω INSULATION

# Volt CVT Refill and Drain Plug

**VOLT**

A new era in  
automotive  
transportation





2011 Chevrolet Volt

Fig. 31: Transmission Drain Plug

Courtesy of GENERAL MOTORS CORP.

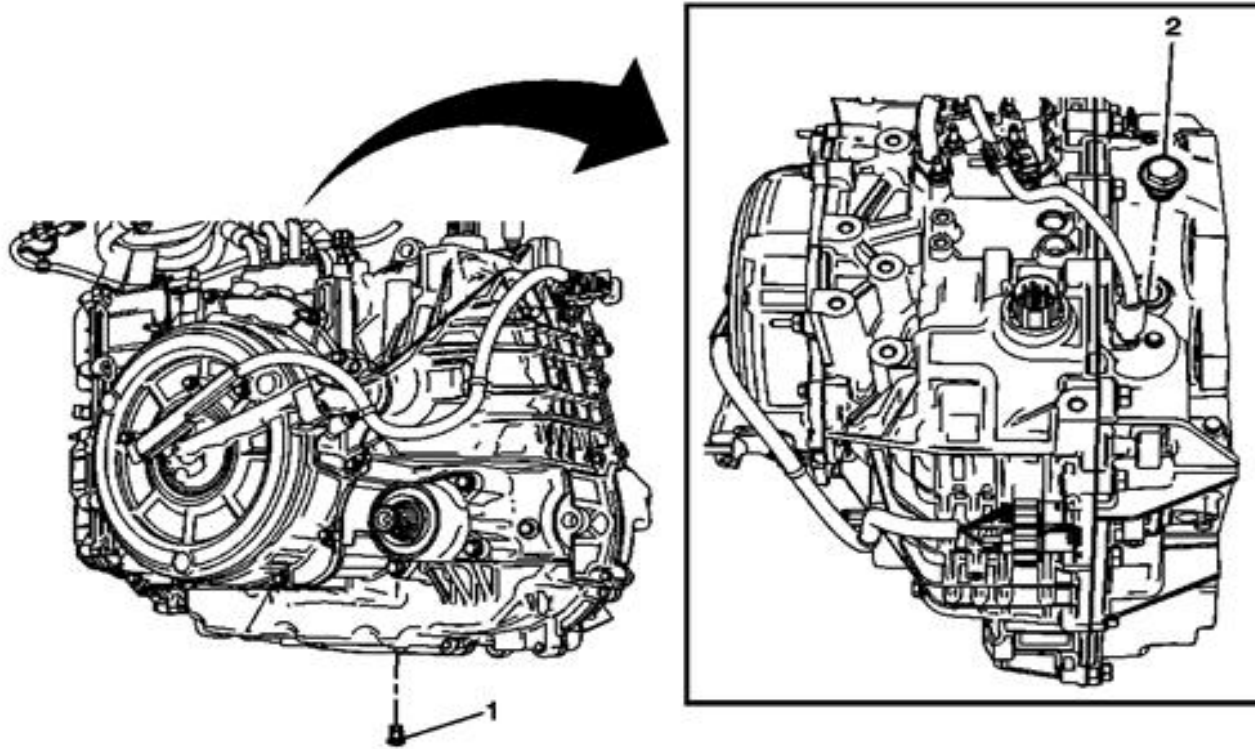



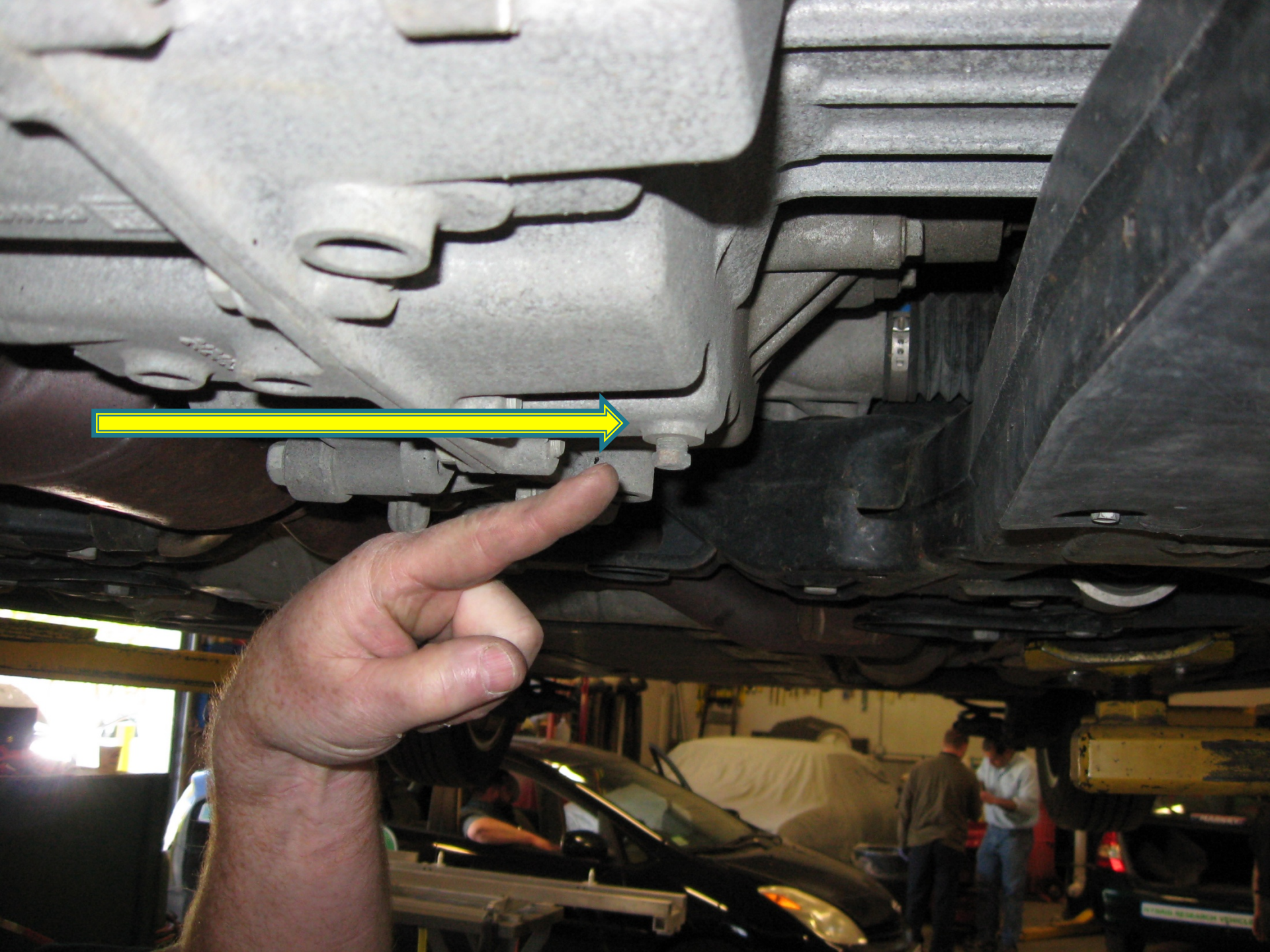



2011 Chevrolet Volt

Fig. 3: Transmission Case Assembly (2 Of 2)

Courtesy of GENERAL MOTORS CORP.

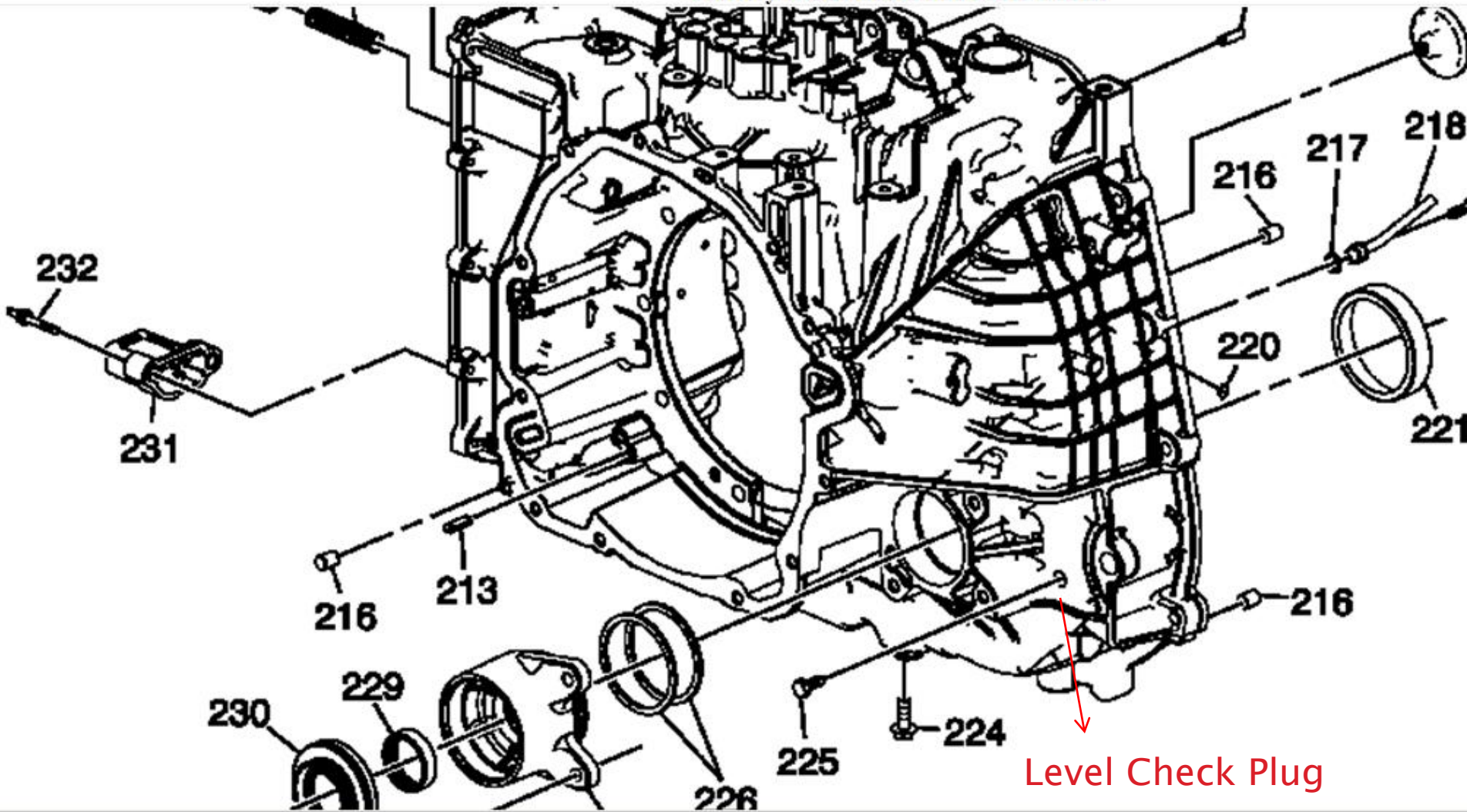



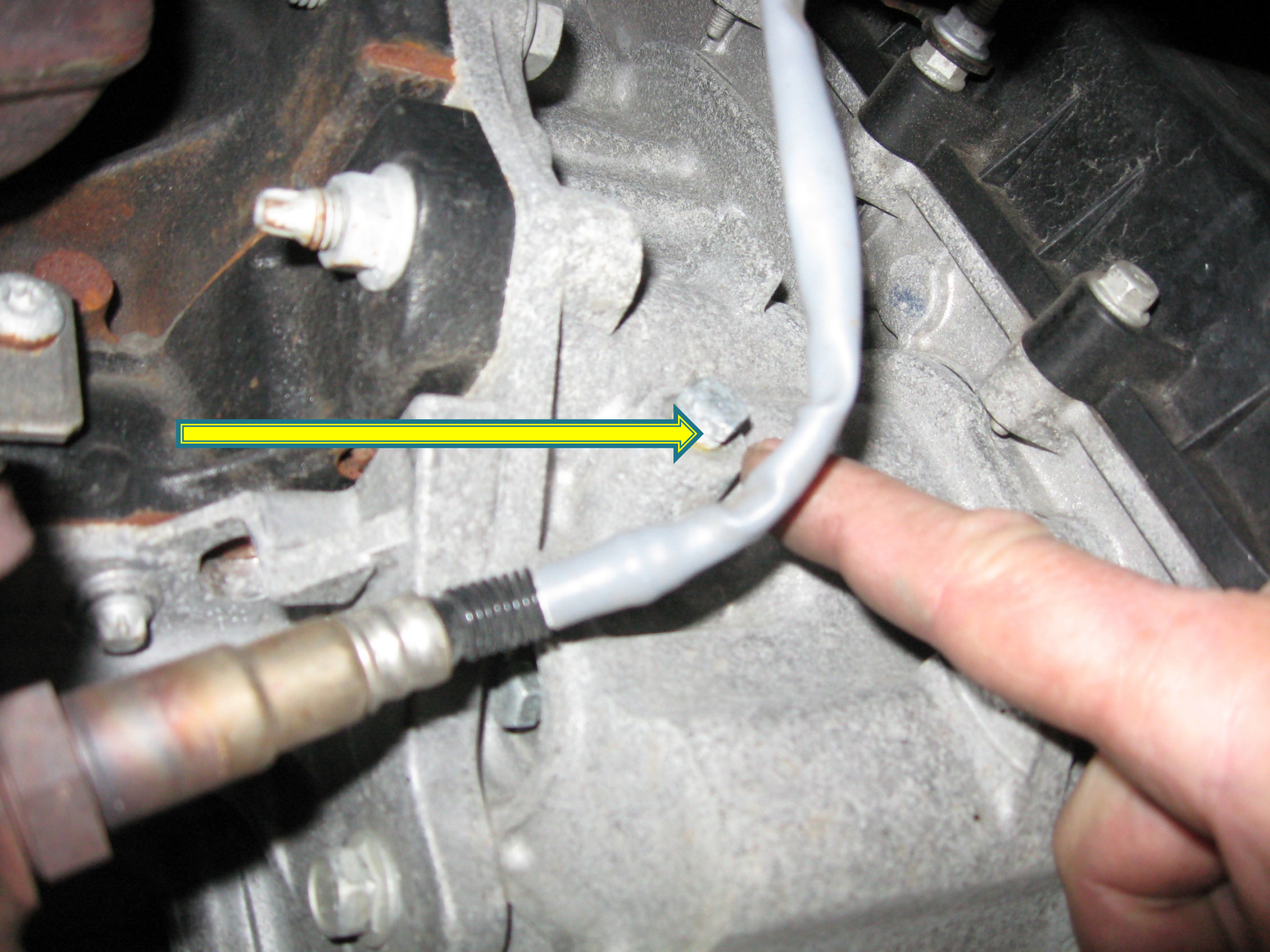



2011 Chevrolet Volt

Fig. 4: Torque/Dampener and Differential (w/Fluid Pump) Housing Assembly

Courtesy of GENERAL MOTORS CORP.

CVT Fill Plug

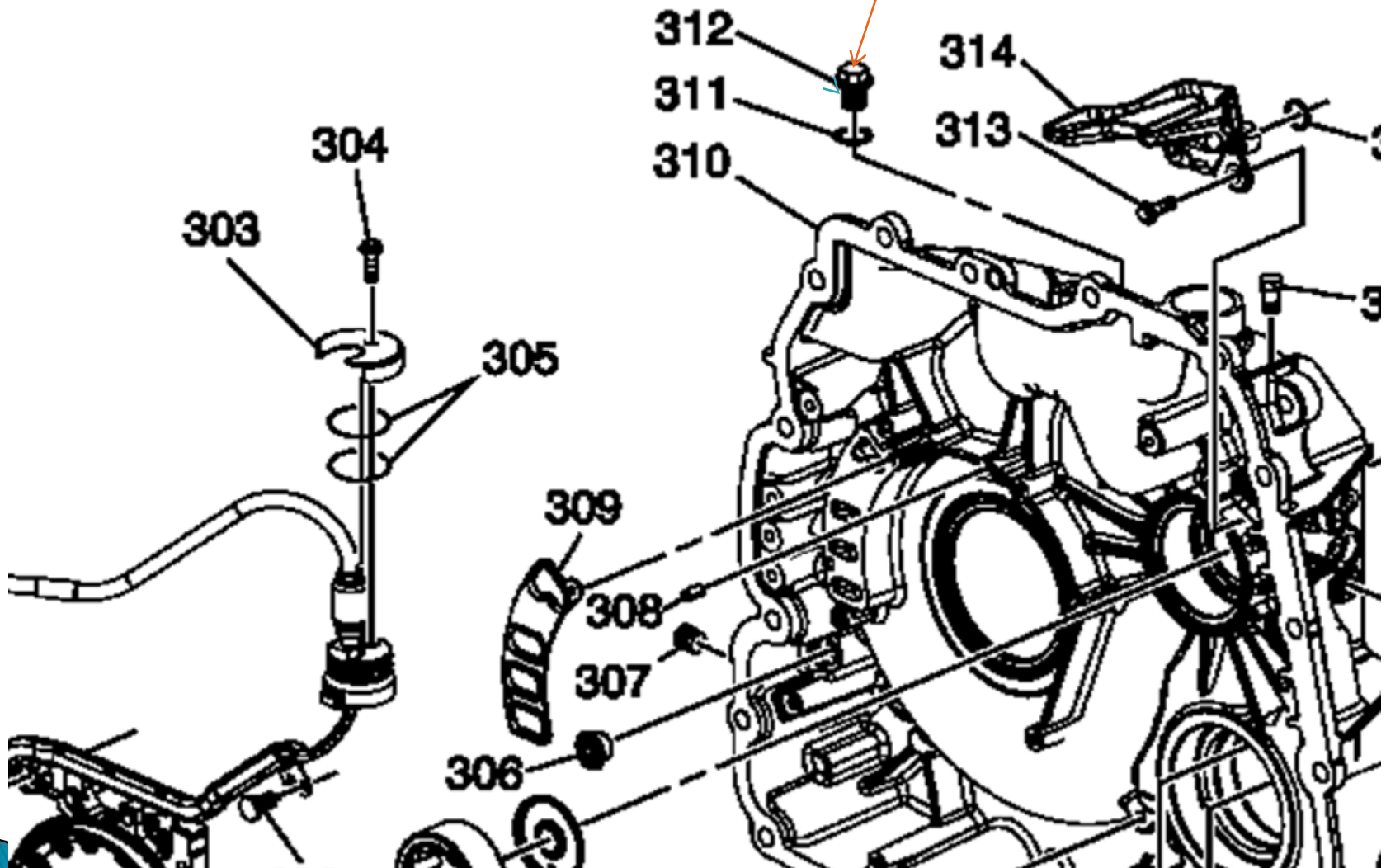



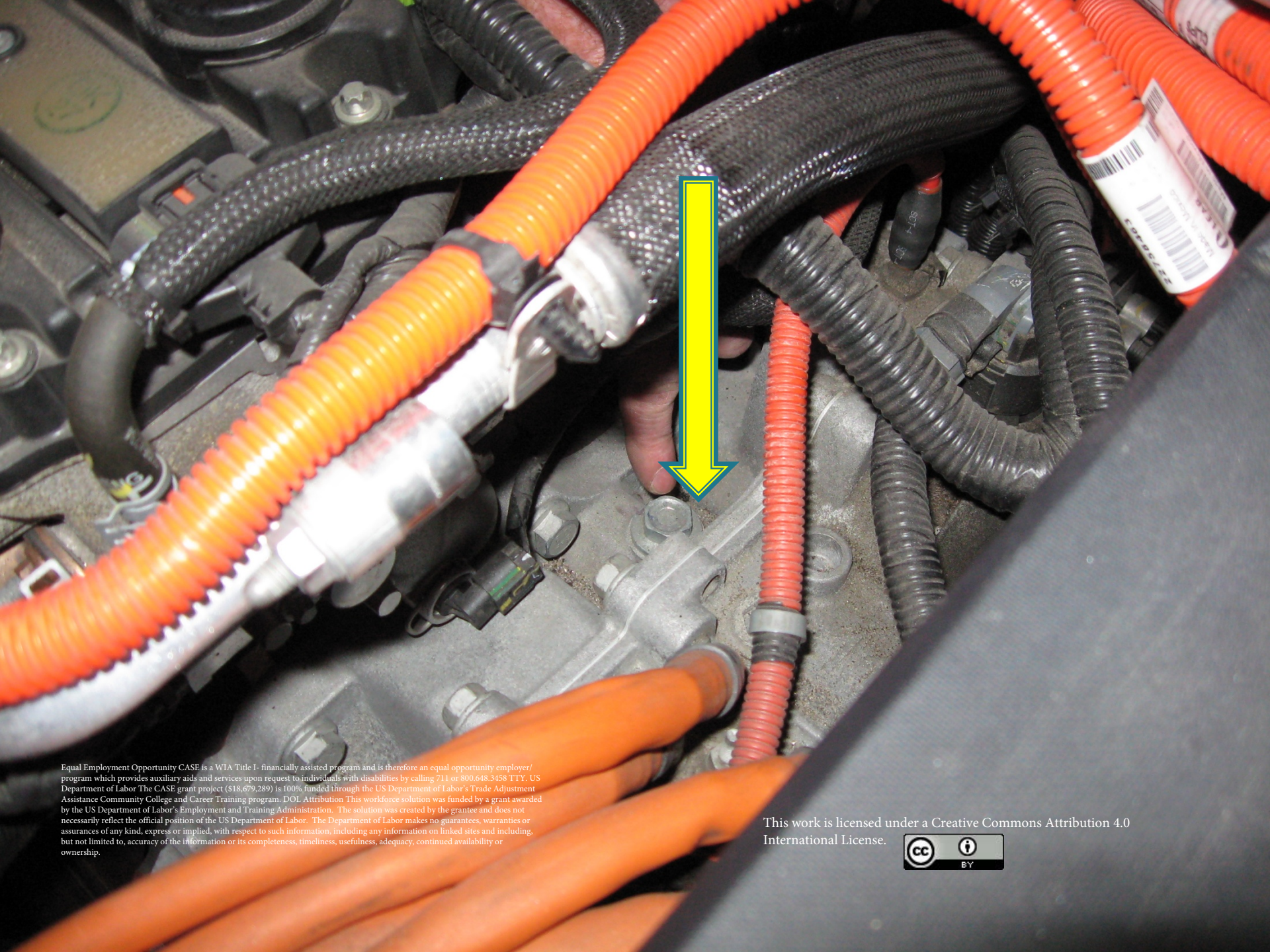

Equal Employment Opportunity CASE is a WIA Title I- financially assisted program and is therefore an equal opportunity employer/ program which provides auxiliary aids and services upon request to individuals with disabilities by calling 711 or 800.648.3458 TTY: US Department of Labor The CASE grant project (\$18,679,289) is 100% funded through the US Department of Labor's Trade Adjustment Assistance Community College and Career Training program. DOL Attribution This workforce solution was funded by a grant awarded by the US Department of Labor's Employment and Training Administration. The solution was created by the grantee and does not necessarily reflect the official position of the US Department of Labor. The Department of Labor makes no guarantees, warranties or assurances of any kind, express or implied, with respect to such information, including any information on linked sites and including, but not limited to, accuracy of the information or its completeness, timeliness, usefulness, adequacy, continued availability or ownership.

This work is licensed under a Creative Commons Attribution 4.0 International License.



Exam

Name \_\_\_\_\_

**MULTIPLE CHOICE. Choose the one alternative that best completes the statement or answers the question.**

- 1) The GM EV-1 was what type of vehicle? 1) \_\_\_\_\_  
A) A parallel-type HEV  
B) The first generation hybrid- electric vehicle (HEV)  
C) A series-type HEV  
D) Totally electric powered
- 2) Which type hybrid uses 36 to 42 volts? 2) \_\_\_\_\_  
A) Strong hybrid  
B) Medium hybrid  
C) Full hybrid  
D) Mild hybrid
- 3) About how fast does a motor-generator crank the internal combustion engine? 3) \_\_\_\_\_  
A) About 1000 RPM  
B) About 2000 RPM  
C) About 350-600 RPM  
D) About 150-300 RPM
- 4) Which type of hybrid electric vehicle has idle stop operation? 4) \_\_\_\_\_  
A) Medium hybrids only  
B) Strong, mild, and medium hybrids  
C) Strong hybrids only  
D) Mild hybrids only
- 5) Electric motors are better than an internal combustion engine to propel a vehicle because 5) \_\_\_\_\_  
\_\_\_\_\_  
A) They produce high torque at low speeds  
B) They are quiet  
C) They do not burn fuel and therefore do not release carbon dioxide into the environment  
D) All of the above are correct
- 6) Technician A says that a major limitation of electric vehicles is their short range. Technician B says that a major advantage of electric vehicles is their quiet operation. Which technician is correct? 6) \_\_\_\_\_  
A) Technician A  
B) Technician B  
C) Both Technicians  
D) Neither Technician
- 7) Which type of motor or engine produces more torque at lower speed? 7) \_\_\_\_\_  
A) Electric  
B) Gasoline
- 8) The abbreviation HEV stands for \_\_\_\_\_. 8) \_\_\_\_\_  
A) High energy voltage  
B) Heated electrolyte valve  
C) Hybrid electric vehicle  
D) None of these are correct

**TRUE/FALSE. Write 'T' if the statement is true and 'F' if the statement is false.**

- 9) In a series hybrid vehicle, the internal combustion engine drives the vehicle only when increased horsepower is needed. 9) \_\_\_\_\_

**MULTIPLE CHOICE. Choose the one alternative that best completes the statement or answers the question.**

- 10) Which of these statements about series hybrid electric vehicles is (are) true? 10) \_\_\_\_\_  
A) The engine never powers the vehicle directly  
B) The internal combustion engine turns a generator to charge the battery  
C) Both A and B  
D) Neither A nor B

- 11) Technician A says that in a parallel hybrid design, only the electric motor is connected to the transmission. Technician B says that in a parallel hybrid design, the vehicle can be propelled by the electric traction motor, the internal combustion engine, or both. Which technician is correct?
- A) Technician A
  - B) Technician B
  - C) Both Technicians
  - D) Neither Technician

11) \_\_\_\_\_

**TRUE/FALSE. Write 'T' if the statement is true and 'F' if the statement is false.**

- 12) Some HEVs can operate using the electric motor alone or with the assist of the internal combustion engine.

12) \_\_\_\_\_

- 1) D
- 2) D
- 3) A
- 4) B
- 5) D
- 6) C
- 7) A
- 8) C
- 9) FALSE
- 10) C
- 11) B
- 12) FALSE



Exam

Name \_\_\_\_\_

**MULTIPLE CHOICE. Choose the one alternative that best completes the statement or answers the question.**

- 1) A hybrid electric vehicle (HEV) gasoline engine usually uses what viscosity of engine oil? 1) \_\_\_\_\_  
A) SAE 10 W-30                      B) SAE 20W-50                      C) SAE 5W-30                      D) SAE 0W-20
  
- 2) Hybrid electric vehicle gasoline engines often use what systems to achieve maximum fuel economy? 2) \_\_\_\_\_  
A) Wideband oxygen sensors                      B) Returnless fuel delivery system  
C) Variable valve timing                      D) All of the above
  
- 3) The Atkinson cycle engine design \_\_\_\_\_. 3) \_\_\_\_\_  
A) Requires special fuel and oil designed for this type of engine  
B) Operates differently than the normal four stroke cycle gasoline engine  
C) Uses the same four stroke cycle but delays the closing of the intake valve  
D) Both A and B are correct
  
- 4) A wide band oxygen sensor is used to \_\_\_\_\_. 4) \_\_\_\_\_  
A) Help improve fuel economy by allowing the engine to operate at a lean air-fuel ratio  
B) Help the engine achieve a super ultra-low emission vehicle (SULEV) rating  
C) Help the engine meet achieve ultra-low emission vehicle (ULEV) rating  
D) All of the above
  
- 5) What type of ignition system is used on hybrid electric vehicle gasoline engines? 5) \_\_\_\_\_  
A) Coil-on-plug system  
B) Waste spark  
C) Distributor-type system with electronic control  
D) Compression sensing ignition
  
- 6) If a wide band oxygen sensor is used, it may be called a \_\_\_\_\_. 6) \_\_\_\_\_  
A) Linear air-fuel sensor                      B) Lean air-fuel sensor  
C) Wide-band oxygen sensor                      D) All of the above
  
- 7) When a engine is operating leaner than 14.7:1 lambda will be \_\_\_\_\_. 7) \_\_\_\_\_  
A) Less than 1.00                      B) More than 1.00                      C) ETC controlled                      D) Closed
  
- 8) The gasoline engines in hybrid vehicles often \_\_\_\_\_. 8) \_\_\_\_\_  
A) Need electric motors to start the ICE                      B) Have a large displacement  
C) Both A and B                      D) Neither A nor B
  
- 9) During a complete combustion cycle in a four-cycle engine, the crankshaft revolves how many degrees? 9) \_\_\_\_\_  
A) 180                      B) 720                      C) 360                      D) 240
  
- 10) Technician A says that torque is a rotating force. Technician B says that torque may not always cause movement. Which technician is correct? 10) \_\_\_\_\_  
A) Technician A                      B) Technician B  
C) Both Technicians                      D) Neither Technician
  
- 11) Hybrid electric vehicles \_\_\_\_\_. 11) \_\_\_\_\_  
A) Usually do not use a conventional starter motor

- B) May use an offset engine crankshaft to reduce internal friction
- C) Both A and B
- D) Neither A nor B

12) Which of these engine types operates most smoothly? 12) \_\_\_\_\_

- A) Six cylinder
- B) Eight cylinder
- C) Four cylinder
- D) There is no noticeable difference.

13) What is the term used to describe engines where the intake valve is left open for a short time after the piston begins its upward travel on the compression stroke? 13) \_\_\_\_\_

- A) Atkinson cycle
- B) Wankel cycle
- C) Miller cycle
- D) None of these

- 1) D
- 2) D
- 3) C
- 4) D
- 5) A
- 6) D
- 7) B
- 8) A
- 9) B
- 10) C
- 11) C
- 12) B
- 13) A

Exam

Name \_\_\_\_\_

**MULTIPLE CHOICE. Choose the one alternative that best completes the statement or answers the question.**

- 1) Deep cycling means \_\_\_\_\_. 1) \_\_\_\_\_  
A) The battery is fully discharged and then recharged  
B) Overcharging the battery  
C) Overfilling or underfilling the battery with water  
D) The battery is overfilled with acid ( $H_2SO_4$ )
  
- 2) What battery rating is tested at 32 deg F? 2) \_\_\_\_\_  
A) Reserve capacity  
B) Battery voltage test  
C) Cold-cranking amperes (CCA)  
D) Cranking amperes (CA)
  
- 3) When load testing a battery, which battery rating is usually used to determine how much load to apply to the battery? 3) \_\_\_\_\_  
A) RC  
B) MCA  
C) CA  
D) CCA
  
- 4) A battery high rate discharge (load capacity) test is being performed on a 12 volt battery. Technician A says that a good battery should have a voltage reading of higher than 9.6 volts while under load at the end of the 15-second test. Technician B says that the battery should be discharged (loaded) to twice its CCA rating. Who is right? 4) \_\_\_\_\_  
A) A only  
B) B only  
C) Both A and B  
D) Neither A nor B
  
- 5) Where are AGM auxiliary batteries usually located in a hybrid electric vehicle? 5) \_\_\_\_\_  
A) Under the front fender  
B) Under the hood  
C) In the trunk/rear area  
D) Under the front seat
  
- 6) Which type of battery is most used in hybrid electric vehicles? 6) \_\_\_\_\_  
A) Sodium nickel chloride  
B) Nickel cadmium  
C) Nickel metal hydride  
D) Lithium ion
  
- 7) An AGM battery differs from a conventional flooded battery in what way? 7) \_\_\_\_\_  
A) It does not contain electrolyte  
B) It does not contain lead  
C) The electrolyte is absorbed into glass separator and will not spill  
D) Each cell has a voltage sensor
  
- 8) Each cell of an automobile 12 volt battery can produce about \_\_\_\_\_ volts. 8) \_\_\_\_\_  
A) 4.2  
B) 1.2  
C) 4  
D) 2.1
  
- 9) Technician A says that an AGM battery can be charged with any battery charger. Technician B says that an AGM battery requires a charger specially designed for charging AGM batteries. Who is correct? 9) \_\_\_\_\_  
A) Technician A only  
B) Technician B only  
C) Both technician A and B  
D) Neither technician A nor B
  
- 10) Technician A says that the state of charge of a NiMH battery can be determined by measuring cell voltage. Technician B says that many factors should be considered in determining the state of charge of a NiMH battery, including temperature, output current, and cell voltage. Which technician is correct? 10) \_\_\_\_\_

- A) Technician A
- C) Both Technicians

- B) Technician B
- D) Neither Technician

- 11) Technician A says the nominal voltage for ONE lead-acid battery cell is 1.2 volts. Technician B says the nominal voltage for ONE NiMH battery cell is 2.1 volts. Which technician is correct? 11) \_\_\_\_\_
- A) Technician A
  - C) Both Technicians
  - B) Technician B
  - D) Neither Technician
- 12) Which batteries use solid electrolytes? 12) \_\_\_\_\_
- A) Lithium-ion
  - C) Lithium-polymer
  - B) NiCd
  - D) NiMH
- 13) Technician A says that NiMH batteries are an alkaline design. Technician B says that high-voltage battery packs are constructed using NiMH cells connected in parallel. Which technician is correct? 13) \_\_\_\_\_
- A) Technician A
  - C) Both Technicians
  - B) Technician B
  - D) Neither Technician
- 14) How are the high voltage batteries cooled in an HEV? 14) \_\_\_\_\_
- A) By forced air from under the vehicle
  - C) By circulating cabin air
  - B) By opening a folding roof flap
  - D) Ice packs
- 15) The HV battery is normally kept at a state of charge (SOC) target of \_\_\_\_\_ percent. 15) \_\_\_\_\_
- A) 100
  - B) 60
  - C) 80
  - D) 20

**TRUE/FALSE. Write 'T' if the statement is true and 'F' if the statement is false.**

- 16) The high voltage battery disconnect should be pulled out before refueling an HEV. 16) \_\_\_\_\_
- 17) Lead-acid batteries release explosive gases when being charged. 17) \_\_\_\_\_
- 18) HEV auxillary batteries can not be safely jump started. 18) \_\_\_\_\_

- 1) A
- 2) D
- 3) D
- 4) A
- 5) C
- 6) C
- 7) C
- 8) D
- 9) B
- 10) B
- 11) D
- 12) C
- 13) A
- 14) C
- 15) B
- 16) FALSE
- 17) TRUE
- 18) FALSE

Exam

Name \_\_\_\_\_

**MULTIPLE CHOICE. Choose the one alternative that best completes the statement or answers the question.**

- 1) All of the following statements are true, EXCEPT \_\_\_\_\_. 1) \_\_\_\_\_  
A) Around every conductor carrying a current is a magnetic field  
B) Magnetic lines of force never intersect  
C) The higher the current through a conductor the stronger the magnetic flux  
D) The magnetic lines of force leave the south pole and enter the north pole
  
- 2) Technician A says that some DC motors use brushes. Technician B says that an AC synchronous motor uses a permanent magnet rotor. Which technician is correct? 2) \_\_\_\_\_  
A) Technician A  
B) Technician B  
C) Both Technicians  
D) Neither Technician
  
- 3) The power of most electric motors is expressed in \_\_\_\_\_. 3) \_\_\_\_\_  
A) Horsepower  
B) Amperes  
C) Watts  
D) kW
  
- 4) AC synchronous motors used in hybrid electric vehicles use how many windings in the stationary part of the motor? 4) \_\_\_\_\_  
A) Two  
B) Three  
C) One  
D) Four
  
- 5) Technician A says that a traction (AC synchronous) motor used in a hybrid electric vehicle is controlled by varying the voltage to the motor. Technician B says that the frequency of the current is controlled. Which technician is correct? 5) \_\_\_\_\_  
A) Technician A  
B) Technician B  
C) Both Technicians  
D) Neither Technician
  
- 6) Technician A says that a DC-to-DC converter is used to convert 12 volts from the battery to a higher voltage to run the electric motor(s) in a hybrid electric vehicle. Technician B says that a DC-to-DC converter is used to convert the voltage from the motor/ generator to a higher voltage to charge the high voltage batteries. Which technician is correct? 6) \_\_\_\_\_  
A) Technician A  
B) Technician B  
C) Both Technicians  
D) Neither Technician
  
- 7) What type of electric motor is used for the traction motor in hybrid electric vehicles? 7) \_\_\_\_\_  
A) Brushless DC motor  
B) AC induction-type motor  
C) DC brush-type motor  
D) Both B and C are used
  
- 8) The \_\_\_\_\_ are used to rectify AC to DC current. 8) \_\_\_\_\_  
A) Diodes  
B) Capacitors  
C) Condensers  
D) Transistors
  
- 9) What is the most common type of rotor used in an AC synchronous motor? 9) \_\_\_\_\_  
A) Wire round  
B) Permanent magnet  
C) Squirrel-cage  
D) Both B and C
  
- 10) Current sensors are commonly used by the motor controller to help with the tasks of motor management. What type of sensor is used for this task? 10) \_\_\_\_\_  
A) Hall-effect  
B) Piezoelectric  
C) Wheatstone bridge  
D) Potentiometer
  
- 11) Technician A says that a broken magnet becomes two magnets. Technician B says that there is a strong

relations 11)  
hip  
between  
magnetis  
m and  
electricit  
y. Which  
technicia  
n is  
correct?

—  
—

- A) Technician A  
B) Technician B  
C) Both Technicians  
D) Neither Technician

- 12) Induced voltages may be increased by \_\_\_\_\_. 12) \_\_\_\_\_  
A) Increasing the number of conductors  
B) Increasing the speed that the conductors pass through the flux field  
C) Increasing the strength of the magnetic field  
D) All of these are correct

**TRUE/FALSE. Write 'T' if the statement is true and 'F' if the statement is false.**

- 13) All electric motors must use direct current. 13) \_\_\_\_\_  
14) All electric motors must use brushes to transfer electric current. 14) \_\_\_\_\_

**MULTIPLE CHOICE. Choose the one alternative that best completes the statement or answers the question.**

- 15) Technician A says that there are nine or more electric motors in electric hybrid vehicles. 15) \_\_\_\_\_  
Technician B says that many of these motors use an electronic module to control their operation.  
Which technician is correct?  
A) Technician A  
B) Technician B  
C) Both Technicians  
D) Neither Technician
- 16) What term describes the ability of an object or surface to store an electric charge? 16) \_\_\_\_\_  
A) inductance                      B) Reluctance                      C) Capacitance                      D) Resistance
- 17) A coil of wire has electrical current flowing through it. Technician A says that you can increase the magnetism of this coil by increasing the number of coils in the wire. Technician B says that you can increase the magnetism of this coil by increasing the current flowing through it. Which technician is correct? 17) \_\_\_\_\_  
A) Technician A  
B) Technician B  
C) Both Technicians  
D) Neither Technician
- 18) A magnetic field is moved past a stationary coil of wire at a 90 degree angle, and electrical current is generated in the wire. What is the term that describes this? 18) \_\_\_\_\_  
A) Production                      B) Induction                      C) Reduction                      D) None of these
- 19) In a synchronous AC motor, the speed of the motor is controlled by changing the \_\_\_\_\_ in the stator. 19) \_\_\_\_\_  
A) Frequency                      B) Voltage                      C) Temperature                      D) Pulse width
- 20) Electric power steering uses an electric motor mounted \_\_\_\_\_. 20) \_\_\_\_\_  
A) On the steering rack  
B) On the steering column  
C) Either A or B  
D) Neither A nor B



21) Capacitors are checked for voltage using a(an) \_\_\_\_\_.

- A) High voltage test light
- C) CAT-III DVOM

- B) Fused jumper wire
- D) None of these

21) \_\_\_\_\_

**TRUE/FALSE. Write 'T' if the statement is true and 'F' if the statement is false.**

22) The hybrid system control unit is air cooled.

22) \_\_\_\_\_

- 1) D
- 2) C
- 3) D
- 4) B
- 5) C
- 6) D
- 7) D
- 8) A
- 9) B
- 10) A
- 11) C
- 12) D
- 13) FALSE
- 14) FALSE
- 15) C
- 16) C
- 17) C
- 18) B
- 19) A
- 20) C
- 21) C
- 22) FALSE

Exam

Name \_\_\_\_\_

**MULTIPLE CHOICE. Choose the one alternative that best completes the statement or answers the question.**

- 1) Kinetic energy is \_\_\_\_\_. 1) \_\_\_\_\_  
A) The energy that the motor produces to propel the vehicle  
B) The energy that the driver exerts on the brake pedal  
C) The energy in any moving object  
D) The energy needed from the batteries to propel a vehicle
  
- 2) Inertia is \_\_\_\_\_. 2) \_\_\_\_\_  
A) The energy of any moving object that has mass (weight)  
B) The force that the internal combustion engine and the electric motor together apply to the drive wheels during rapid acceleration  
C) The electric motor force that is applied to the drive wheels  
D) The force that the driver exerts on the brake pedal during a stop
  
- 3) During braking on a hybrid electric vehicle equipped with a regenerative braking system, what occurs when the driver depresses the brake pedal? 3) \_\_\_\_\_  
A) The motors become generators.  
B) The batteries are charged to 100 percent SOC.  
C) The friction brakes are only used as a backup and not used during normal braking.  
D) The driver needs to apply a braking lever instead of depressing the brake pedal to energize the regenerative braking system.
  
- 4) Technician A says that a front wheel drive hybrid electric vehicle can only generate electricity during braking from the front wheel motor(s). Technician B says that antilock braking (ABS) is not possible with a vehicle equipped with a regenerative braking system. Who is correct? 4) \_\_\_\_\_  
A) Technician A only  
B) Technician B only  
C) Both Technicians A and B  
D) Neither Technician A nor B
  
- 5) In a regenerative braking system, which part of the electric motor is being controlled by the computer? 5) \_\_\_\_\_  
A) Both the rotor and the stator  
B) The stator  
C) Neither the rotor nor the stator  
D) The rotor
  
- 6) In a Toyota Prius regenerative braking system, how many pressure *sensors* are used? 6) \_\_\_\_\_  
A) Three  
B) Two  
C) One  
D) Four
  
- 7) In a Toyota Prius regenerative braking system, how many pressure *switches* are used? 7) \_\_\_\_\_  
A) Four  
B) One  
C) Three  
D) Two
  
- 8) The high voltage batteries are designed to be charged no more than \_\_\_\_\_. 8) \_\_\_\_\_  
A) 100 %  
B) 80 %  
C) None of these  
D) 60 %
  
- 9) What position is the throttle pedal in during regenerative braking? 9) \_\_\_\_\_  
A) The throttle is ignored  
B) About 10 %  
C) None of these  
D) Fully lifted
  
- 10) In the Toyota Prius, which controller is responsible for regenerative braking control? 10) \_\_\_\_\_  
A) The ABS ECU  
B) The engine ECU  
C) The body control module (BCM)  
D) The Hybrid ECU

- 11) When changing the brake pads on a Ford Escape hybrid, what precaution must be taken before removing the brake pads? 11) \_\_\_\_\_
- A) Use a scan tool to enter Pad Service Mode.
  - B) Block all 4 wheels.
  - C) Always change the rear pads before changing the front pads.
  - D) Only change one pad at a time.
- 12) Regenerative braking uses the inertia of the vehicle to recapture energy during braking. Where is this recaptured energy stored? 12) \_\_\_\_\_
- A) In large resistors
  - B) In the electrohydraulic master cylinder
  - C) In the 12 volt battery bank
  - D) In the high voltage battery bank
- 13) The hybrid vehicle electric motor is usually a(an) \_\_\_\_\_ type motor. 13) \_\_\_\_\_
- A) AC
  - B) DC
  - C) HVAC
  - D) None of these
- 14) A brushless motor works by \_\_\_\_\_. 14) \_\_\_\_\_
- A) Rapidly switching the polarity of the permanent magnet rotor
  - B) Rapidly switching the stator field windings
  - C) Either of these
  - D) Neither of these
- 15) Some hybrid vehicles reduce the internal combustion engine's braking capacity during deceleration so that the regenerative braking is more efficient. This is done by \_\_\_\_\_. 15) \_\_\_\_\_
- A) Disabling the spark in some cylinders
  - B) Releasing compression in some cylinders
  - C) Closing the valves in some cylinders
  - D) None of these
- 16) When the electric motor is acting as a generator it produces alternating current (AC). This current is converted to direct current (DC) by use of \_\_\_\_\_. 16) \_\_\_\_\_
- A) Large diodes
  - B) Special AC batteries
  - C) Large capacity filters
  - D) None of these

- 1) C
- 2) A
- 3) A
- 4) A
- 5) B
- 6) D
- 7) D
- 8) B
- 9) D
- 10) A
- 11) A
- 12) D
- 13) A
- 14) B
- 15) C
- 16) A

Exam

Name \_\_\_\_\_

**MULTIPLE CHOICE. Choose the one alternative that best completes the statement or answers the question.**

1) In a GM two-mode hybrid electric vehicle, when can the vehicle be powered by electric power alone? 1) \_\_\_\_\_

- A) During heavy load conditions regardless of mode
- B) During the second mode
- C) During either the first or second mode
- D) During the first mode

2) Modifications to automatic transmissions used in hybrid vehicles include \_\_\_\_\_. 2) \_\_\_\_\_

- A) Electric auxiliary transmission fluid pumps
- B) Modified torque converter lockup schedule
- C) Increased number of plates in multiple-disc clutches
- D) Both A and B are correct

3) Technician A says that power-split CVTs use a torque converter. Technician B says that power-split CVTs use an electric transmission fluid pump. Which technician is correct? 3) \_\_\_\_\_

- A) Technician A B) Technician B
- C) Both Technicians D) Neither Technician

4) All of the following statements concerning power-split CVTs are true EXCEPT \_\_\_\_\_. 4) \_\_\_\_\_

- A) One of the planetary members must be held to make the power-split CVT work
- B) The power-split CVT can operate in electric mode only
- C) The ICE and motor-generators are all connected through a planetary gearset
- D) Power-split CVT systems do not use a separate starter motor

5) The Honda CVT is connected to the ICE with a \_\_\_\_\_. 5) \_\_\_\_\_

- A) Drive plate and flywheel B) Torque converter
- C) Manually operated clutch mechanism D) None of the above

6) In a Toyota/Lexus hybrid vehicle, how is reverse achieved? 6) \_\_\_\_\_

- A) The ICE reverses direction and powers the drive wheels
- B) MG2 is used to power the vehicle in reverse
- C) MG1 is used to power the vehicle in reverse
- D) Either B or C, depending on the exact model and year

7) How many primary designs of CVTs are currently being used in hybrid electric vehicles? 7) \_\_\_\_\_

- A) One B) Three C) Two D) Eight

8) Technician A says that a continuously variable transmission is an automatic transmission that does not shift gears. Technician B says that a continuously variable transmission has a maximum of six distinct gear ranges. Which technician is correct? 8) \_\_\_\_\_

- A) Technician A B) Technician B
- C) Both Technicians D) Neither Technician

9) What has been used to increase the efficiency of automatic transmissions? 9) \_\_\_\_\_

- A) Continuously variable transmissions that allow the internal combustion engine to remain in an RPM range for peak torque efficiency

B) Electronic controls that compensate for wear in friction components

C) Lockup torque converter

D) All of these increase the efficiency of automatic transmissions.

10) In a Toyota power-split system, when the planetary ring gear is not moving \_\_\_\_\_.

10) \_\_\_\_\_

A) There is a fault      B) The vehicle is not moving

C) The vehicle is in reverse      D) None of these

- 1) D
- 2) D
- 3) D
- 4) A
- 5) A
- 6) B
- 7) C
- 8) A
- 9) D
- 10) B



Exam

Name \_\_\_\_\_

**MULTIPLE CHOICE. Choose the one alternative that best completes the statement or answers the question.**

1) Where is the 12-volt battery located in a Toyota Prius? 1) \_\_\_\_\_

- A) Under the hood, driver's side B) In the trunk  
C) Under the hood, passenger's side D) Under the back seat

2) Pressing the POWER button one time, without depressing the brake pedal, causes the system to enter what mode?  
2) \_\_\_\_\_

- A) Accessory B) Vehicle started C) Ready D) Ignition on

3) On a Prius, what does the "B" mean on the shift indicator? 3) \_\_\_\_\_

- A) Braking B) Back up C) Battery D) Booking

4) In order for a Toyota Prius to start, what has to be OK? 4) \_\_\_\_\_

- A) The brake pedal must be depressed  
B) The auxiliary 12- volt battery must be sufficiently charged  
C) The high- voltage battery has to be sufficiently charged to crank the engine  
D) All of the above

5) The high-voltage batteries in Toyota hybrid electric vehicles are cooled by \_\_\_\_\_. 5) \_\_\_\_\_

- A) An air conditioning evaporator B) Cabin air  
C) Phase-change liquid D) Coolant

6) Where is the high voltage disconnect plug on a Prius? 6) \_\_\_\_\_

- A) Under the hood, passenger's side B) Under the hood, driver's side  
C) In the trunk D) To the left of the driver, next to the seat

7) The second-generation Prius has many "by wire" features. These include all of these EXCEPT \_\_\_\_\_. 7) \_\_\_\_\_

- A) Brake B) Throttle C) Steering D) Shift

8) Technician A says that the Prius has a backup 12-volt starter mounted on the outside of the transaxle housing. Technician B says that it has an auxiliary 12-volt jumper cable terminal under the hood in case it runs out of fuel and the high voltage battery unit is discharged. Which technician is correct? 8) \_\_\_\_\_

- A) Technician A B) Technician B  
C) Both Technicians D) Neither Technician

9) Technician A says that the first friction component to wear in the Prius is the set of brushes in the permanent magnet motor. Technician B says that the Toyota power split HEV system does not require torque converters. Which technician is correct? 9) \_\_\_\_\_

- A) Technician A B) Technician B  
C) Both Technicians D) Neither Technician

10) What indication does the Prius instrument cluster show to signal the vehicle is OK to drive? 10) \_\_\_\_\_

- A) Ignition B) On C) Ready D) None of these

- 1) B
- 2) A
- 3) A
- 4) D
- 5) B
- 6) C
- 7) C
- 8) D
- 9) B
- 10) C

Exam

Name \_\_\_\_\_

**MULTIPLE CHOICE. Choose the one alternative that best completes the statement or answers the question.**

- 1) How is the high-voltage battery recharged in a Chevrolet Volt? 1) \_\_\_\_\_  
A) By using a special high-voltage battery charger at a shop or dealer only  
B) Can be charged using the gasoline engine or by plugging it into an outlet  
C) By plugging the vehicle into an electrical outlet  
D) By running the engine
- 2) What type of batteries are used in the Saturn VUE and Chevrolet Malibu BAS hybrid? 2) \_\_\_\_\_  
A) 36-volt NiMH      B) 300-volt NiMH  
C) 144-volt D-cell size NiMH      D) Three 12-volt valve-regulated lead-acid
- 3) Where are the electric motors in the two-mode hybrid vehicle? 3) \_\_\_\_\_  
A) Inside the transmission housing  
B) At the rear of the engine  
C) Belt driven in the front of the engine  
D) At the rear (output shaft) of the transmission
- 4) The batteries used in the two-mode hybrid vehicles are \_\_\_\_\_. 4) \_\_\_\_\_  
A) 300-volt NiMH      B) 144-volt D-cell size NiMH  
C) 36-volt NiMH      D) Three 12-volt valve regulated lead-acid
- 5) The Saturn VUE hybrid uses an electric motor/generator instead of \_\_\_\_\_. 5) \_\_\_\_\_  
A) An alternator and a separate starter      B) A water pump  
C) A transaxle      D) A drive belt
- 6) Where is the GM two-mode HV battery located? 6) \_\_\_\_\_  
A) Behind the rear seat      B) Under the hood, next to the engine  
C) Under the rear seat      D) In the trunk
- 7) The engine in the VOLT will start when the HV battery reaches a charge level of \_\_\_\_\_. 7) \_\_\_\_\_  
A) 100%      B) 30%      C) 80%      D) 0%
- 8) The VOLT HV battery is a \_\_\_\_\_ volt battery pack. 8) \_\_\_\_\_  
A) 42      B) 300      C) 346      D) 144
- 9) If the Chevy VOLT engine has not run for many weeks of electric driving, the vehicle will enter \_\_\_\_\_ mode. 9) \_\_\_\_\_  
A) Fuel weathering      B) Lubrication  
C) Default      D) Engine maintenance
- 10) The Chevy VOLT HV battery coolant is pressurized to \_\_\_\_\_ psi. 10) \_\_\_\_\_  
A) 15      B) 20      C) 8      D) 5

- 1) C
- 2) A
- 3) A
- 4) A
- 5) A
- 6) C
- 7) B
- 8) C
- 9) D
- 10) D

Exam

Name \_\_\_\_\_

**MULTIPLE CHOICE. Choose the one alternative that best completes the statement or answers the question.**

1) Rubber gloves should be worn whenever working on or near the high-voltage circuits or components of a hybrid electric vehicle. Technician A says that the rubber gloves should be rated at 1000 volts or higher. Technician B says that leather gloves should be worn over the high-voltage rubber gloves. Which technician is correct? 1) \_\_\_\_\_

- A) Technician A B) Technician B
- C) Both Technicians D) Neither Technician

2) A CAT III certified DMM should be used whenever measuring high-voltage circuits or components. The CAT III rating relates to \_\_\_\_\_. 2) \_\_\_\_\_

- A) High voltage B) High energy
- C) High electrical resistance D) Both A and B

3) If the engine is not running, technician A says that the high-voltage circuits are depowered. Technician B says that all high voltage wiring is orange in color. Which technician is correct? 3) \_\_\_\_\_

- A) Technician A B) Technician B
- C) Both Technicians D) Neither Technician

4) Two technicians are discussing jump starting a hybrid electric vehicle. Technician A says that the high-voltage batteries can be jumped on some HEV models. Technician B says that the 12-volt auxiliary battery can be jumped using a conventional jump box or jumper cable. Which technician is correct? 4) \_\_\_\_\_

- A) Technician A B) Technician B
- C) Both Technicians D) Neither Technician

5) What can occur if a hybrid electric vehicle is pushed in the shop? 5) \_\_\_\_\_

- A) The tires will be locked unless the ignition is on
- B) The HV battery pack can be damaged
- C) Damage to the electronic controller can occur
- D) High voltage will be generated by the motor/ generator

6) How should NiMH batteries be disposed of? 6) \_\_\_\_\_

- A) Call an 800 number shown under the hood of the vehicle for information
- B) In the regular trash
- C) Burned at an EPA-certified plant
- D) Submerged in water and then disposed of in the regular trash

7) How often should linesman's gloves be inspected by a qualified testing lab? 7) \_\_\_\_\_

- A) Yearly B) Monthly
- C) Every six months D) Daily

8) Technician A says that the high voltage cables may be repaired if damaged while lifting on a vehicle hoist. Technician B says that a paint oven does not get hot enough to damage high voltage cables or other hybrid components. Which technician is correct? 8) \_\_\_\_\_

- A) Technician A B) Technician B
- C) Both Technicians D) Neither Technician

9) Some hybrid air conditioning systems use an electrically driven compressor that uses a special lubricant. What precaution should be taken when servicing these systems? 9) \_\_\_\_\_

- A) A special gauge set
- B) Low pressure pump
- C) Extra refrigerant filters
- D) A dedicated recycling machine for the HEV

10) Servicing the base brakes on a hybrid vehicle requires the technician to \_\_\_\_\_. 10) \_\_\_\_\_

- A) Replace the pads when needed, just as on any other vehicle
- B) De-power and disconnect the HV battery
- C) Disconnect the brake regeneration cables
- D) None of these

- 1) C
- 2) D
- 3) B
- 4) C
- 5) D
- 6) A
- 7) C
- 8) D
- 9) D
- 10) A

Equal Employment Opportunity CASE is a WIA Title I- financially assisted program and is therefore an equal opportunity employer/program which provides auxiliary aids and services upon request to individuals with disabilities by calling 711 or 800.648.3458 TTY. US Department of Labor The CASE grant project (\$18,679,289) is 100% funded through the US Department of Labor's Trade Adjustment Assistance Community College and Career Training program. DOL Attribution This workforce solution was funded by a grant awarded by the US Department of Labor's Employment and Training Administration. The solution was created by the grantee and does not necessarily reflect the official position of the US Department of Labor. The Department of Labor makes no guarantees, warranties or assurances of any kind, express or implied, with respect to such information, including any information on linked sites and including, but not limited to, accuracy of the information or its completeness, timeliness, usefulness, adequacy, continued availability or ownership.

This work is licensed under a Creative Commons Attribution 4.0 International License.

