

MIRLSim



User Manual

Mineral Industry Research Laboratory

University of Alaska Fairbanks

April 2018

mirl.uaf.edu

Contents

1. Installation.....	3
1.1 System Requirements.....	3
2. Different Unit Processes	
3. Operation.....	19
3.1 Getting Started	28
3.2 Data	8
3.3 Simulating the flowsheet.....	35
3.4 Simulation Results	37
4. Example	39
4.1 Circuit Description.....	39
4.2 Objective	40
5. Reference	41

List of Figures

Figure 1: Drawing Canvas	28
Figure 2: Add Equipment	29
Figure 3: Selection of Equipment Icon, Left: Single Unit, Right: Multiple Unit	30
Figure 4: Possibilities for joining stream lines	31
Figure 5: Create Stream Line.....	6
Figure 6: Delete Stream Line.....	32
Figure 7: Product Stream	7
Figure 8: Equipment Setting Dialog for Ball Mill.....	8
Figure 9: Circuit Settings	9
Figure 10: Start/Stop Simulations.....	36
Figure 11: Input-Output Tabs	37
Figure 12: Input Data to Ball Mill	37
Figure 13: Display of process variables on drawing canvas.....	38
Figure 14: Choosing variables to be displayed.....	38
Figure 15: Data Trends	39
Figure 16: Example Flowsheet.....	40

1. Installation

MIRLSim is an application file which can be downloaded by following the link below

<http://mirl.uaf.edu>

1.1 System Requirements

Software

This version is compatible with Windows and has been tested on Windows 7. It will work well with any Windows 7 or newer versions (32-bit and 64-bit). It does not require any additional external program to run. The minimum system requirement is:

- Dual Core processor
- 2 GB RAM

Hardware:

The software will acquire a disk space of 98 MB

1. After downloading the package run the installation wizard by clicking on  .exe icon.
2. Complete the installation as directed
3. After the software is installed it is ready for use.

Attribution and License:

This workforce product was funded by an \$8.1M TAACCCT grant awarded by the U.S.

Department of Labor's Employment and Training Administration. The product was created by the grantee and does not necessarily reflect the official position of the U.S. Department of Labor. The U.S. Department of Labor makes no guarantees, warranties, or assurances of any kind, express or implied, with respect to such information, including any information on linked sites and including, but not limited to, accuracy of the information or its completeness, timeliness, usefulness, adequacy, continued availability, or ownership.

Creative Commons License Type: CCBY 4.0

2. Different Unit Processes

Right clicking on the empty template will open a dialog box as shown below. The user can select any item on the list to start drawing the circuit.

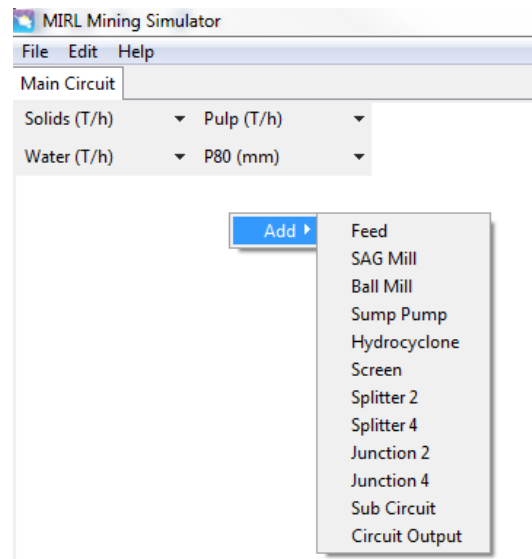

There are six unit process that the user can add to their circuit. They are as follows:

1. Feed
2. Ball Mill
3. Semi-Autogenous Mill (SAG Mill)
4. Hydrocyclone
5. Sump Pump
6. Screen

Apart from these six unit processes, there are some added features that makes the simulator easy to use. They necessarily do not exist in plants, but help the user in simplifying/understanding the circuit easy. They are as follows:

1. Splitter 2
2. Splitter 4
3. Junction 2
4. Junction 4
5. Sub circuit
6. Circuit output

Details regarding each equipment will be stated in the following pages.

2.1 Feed

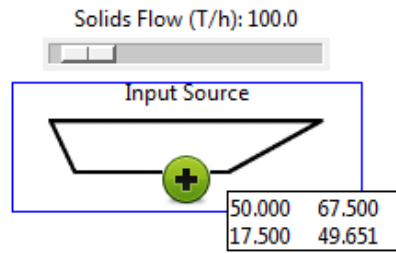

Feed Icon

Right clicking on the feed icon will open menu named “Input Source Settings”. By clicking, it will open a new tab in which the user can change the settings regarding the input to the circuit.

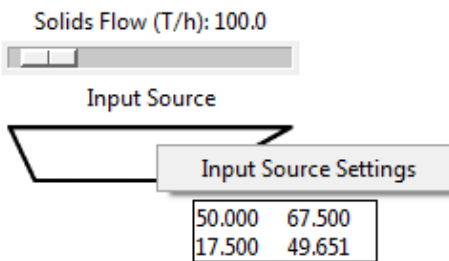

The maximum tonnage from a single feed is set at 2000 tph. If the user wants to have a feed greater than 2000 tph, they can add more feed to the circuit.

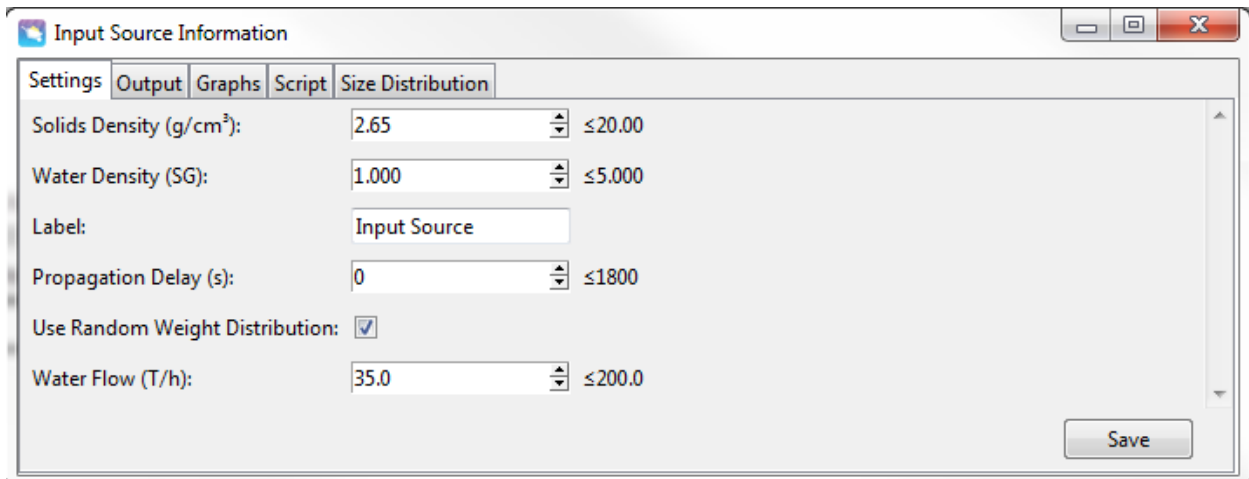

In this tab the user can change the ore characteristics like specific gravity, specific gravity of water, propagation delay, and tonnage of water. By default, the passing fraction of different size

ranges is set as shown in the image below, but the user can enter their own values as long as they are logical.

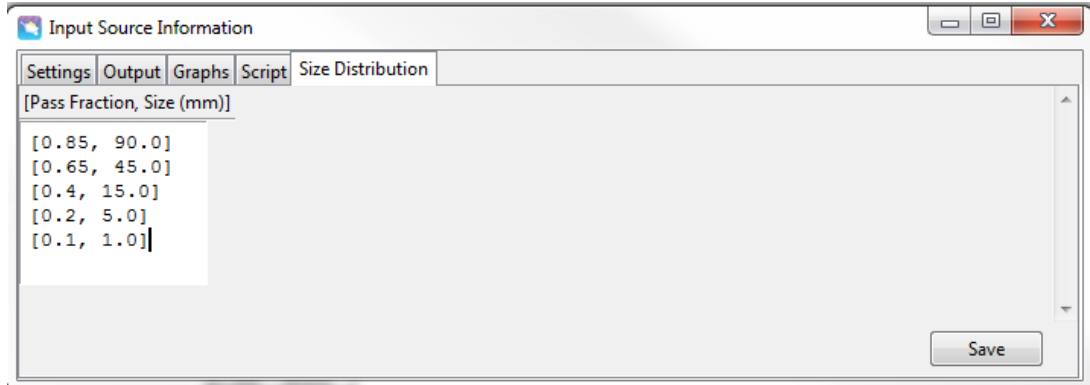

The “Output” tab will show the weight distribution of the input feed and also different calculations like Power (in kW), pulp TPH, etc.

The screenshot shows the 'Input Source Information' dialog box with the 'Output' tab selected. It displays a table with the following data:

Size Range (mm)	Flow (T/h)	Flow (%)	Attributes	Value
137.0 - 123.0	5.235	5.235	Solids Density (SG)	2.65
123.0 - 111.0	9.703	9.703	Solids Flow (T/h)	100.00
111.0 - 100.0	8.561	8.561	Solids Flow (m³/h)	37.74
100.0 - 90.00	7.796	7.796	Solids Flow (gal/min)	8.57
90.00 - 81.00	5.999	5.999	Solids Proportion (%)	74.07
81.00 - 72.90	4.461	4.461	Water Density (SG)	1.00
72.90 - 65.60	4.146	4.146	Water Flow (T/h)	35.00
65.60 - 59.00	3.863	3.863	Water Flow (m³/h)	35.00
59.00 - 53.10	3.586	3.586	Water Flow (gal/min)	7.95
53.10 - 47.80	3.316	3.316	Pulp Density (SG)	1.86
47.80 - 43.00	3.086	3.086	Pulp Flow (T/h)	135.00
43.00 - 38.70	2.618	2.618	Pulp Flow (m³/h)	72.74
38.70 - 34.90	2.399	2.399	Pulp Flow (gal/min)	16.52
34.90 - 31.40	2.247	2.247	D80 RR New (mm)	45.65
31.40 - 28.20	2.144	2.144	D80 RR Old (mm)	95.52
28.20 - 25.40	1.997	1.997	D80 GGS (mm)	130.00
25.40 - 22.90	1.834	1.834	D80 Linear (mm)	99.29
22.90 - 20.60	1.726	1.726	Power (kW)	0.00
20.60 - 18.50	1.645	1.645		

The “Graph” tab will show the different graphs.

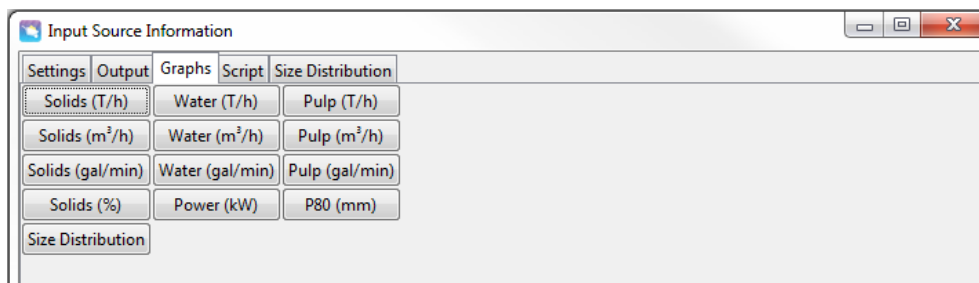

The user can change the feed tonnage by dragging the slider on the feed icon left or right.

The “Script” allows the user to enter or save the current scenario to run the simulations. The files must be MS Excel (converted to .csv files). Here the user can also upload their own MS Excel file by clicking on the “Script” icon and then selecting “Load CSV” button.

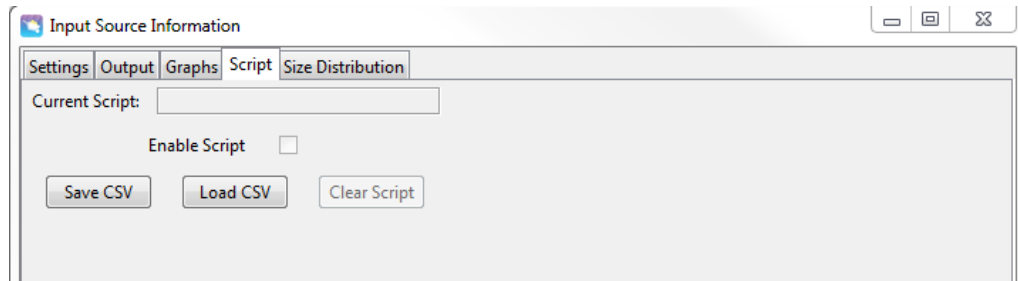

2.2 Ball Mill

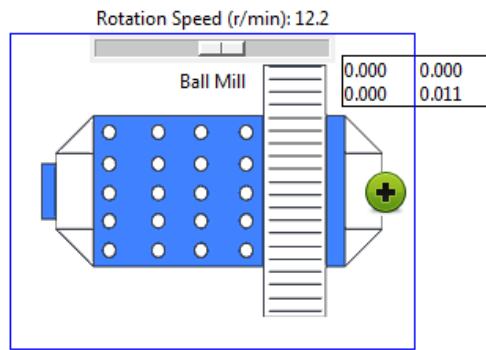

Ball Mill Icon

To change settings of Ball Mill, the user has to right click on the ball mill icon. A menu will pop up with the title “Mill Settings”.

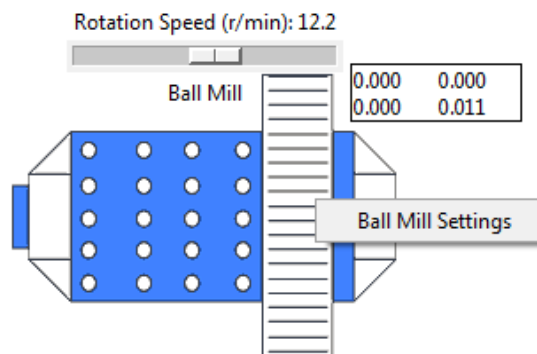

On clicking the icon, a tab containing all the parameters will open.

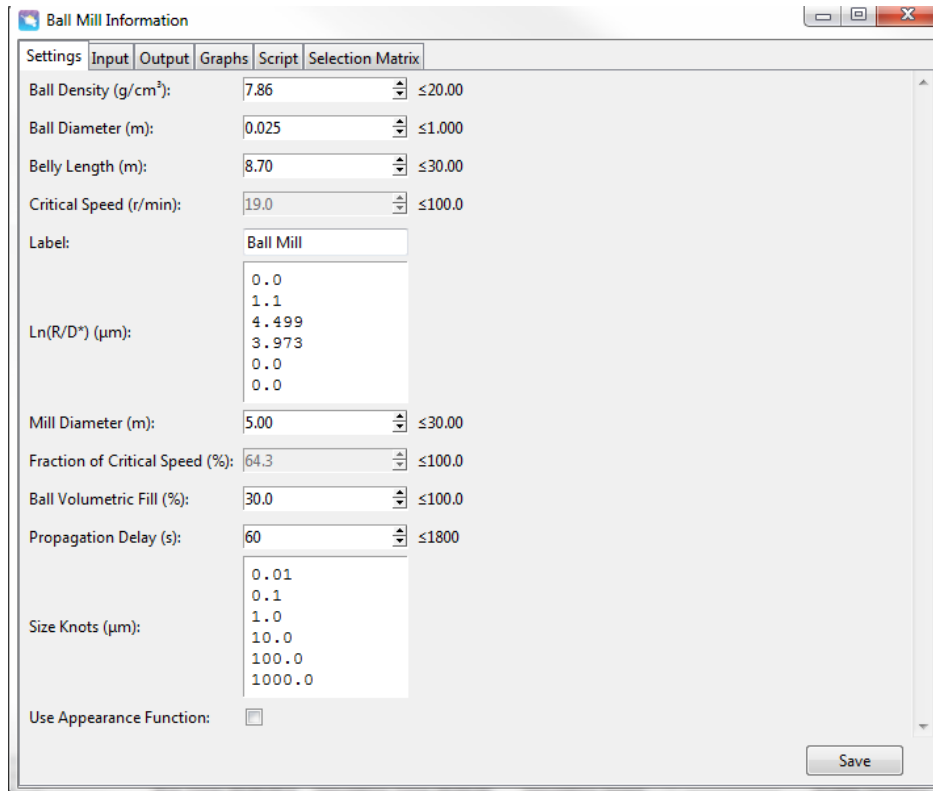

“Propagation delay” means the delay in output of ball mill. 1 step delay is equal to 1 second. So if a user opts for larger step delay, the output of ball mill will take longer to display.

“Appearance Function” relates to the retention of material in the ball mill. In the ideal situation, there will be no retention of material in the ball mill. If the user wants no retention of material in the ball mill, then they can check the “Use appearance function” box.

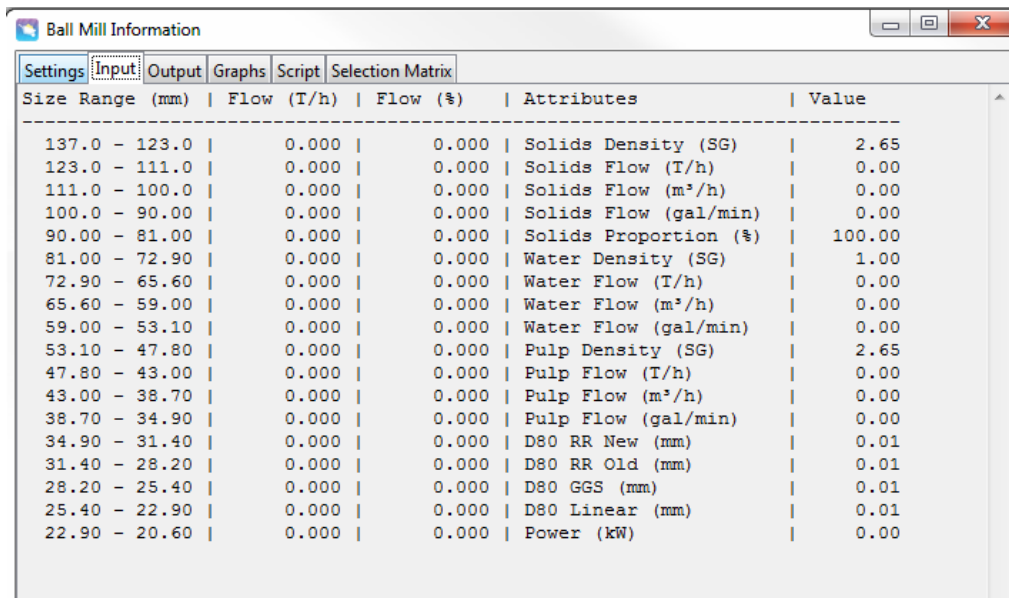

Size Range (mm)	Flow (T/h)	Flow (%)	Attributes	Value
137.0 - 123.0	0.000	0.000	Solids Density (SG)	2.65
123.0 - 111.0	0.000	0.000	Solids Flow (T/h)	0.00
111.0 - 100.0	0.000	0.000	Solids Flow (m ³ /h)	0.00
100.0 - 90.00	0.000	0.000	Solids Flow (gal/min)	0.00
90.00 - 81.00	0.000	0.000	Solids Proportion (%)	100.00
81.00 - 72.90	0.000	0.000	Water Density (SG)	1.00
72.90 - 65.60	0.000	0.000	Water Flow (T/h)	0.00
65.60 - 59.00	0.000	0.000	Water Flow (m ³ /h)	0.00
59.00 - 53.10	0.000	0.000	Water Flow (gal/min)	0.00
53.10 - 47.80	0.000	0.000	Pulp Density (SG)	2.65
47.80 - 43.00	0.000	0.000	Pulp Flow (T/h)	0.00
43.00 - 38.70	0.000	0.000	Pulp Flow (m ³ /h)	0.00
38.70 - 34.90	0.000	0.000	Pulp Flow (gal/min)	0.00
34.90 - 31.40	0.000	0.000	D80 RR New (mm)	0.01
31.40 - 28.20	0.000	0.000	D80 RR Old (mm)	0.01
28.20 - 25.40	0.000	0.000	D80 GGS (mm)	0.01
25.40 - 22.90	0.000	0.000	D80 Linear (mm)	0.01
22.90 - 20.60	0.000	0.000	Power (kW)	0.00

The above two tabs show the difference between the weight distribution in different size ranges for a particular input and output of a ball mill.

The variables for the ball mill include the ball density (in gm/cm³), ball diameter (in meter), belly length (in meter), mill diameter (in meter), volume of balls (in %), and rotation speed (in RPM).

After making all the changes, the user has to save them by clicking on the “Save” button.

Similar to the feed, the user can change the RPM of ball mill by dragging the slider on the ball mill icon left or right.

The “Graph” tab will show the different graphs.

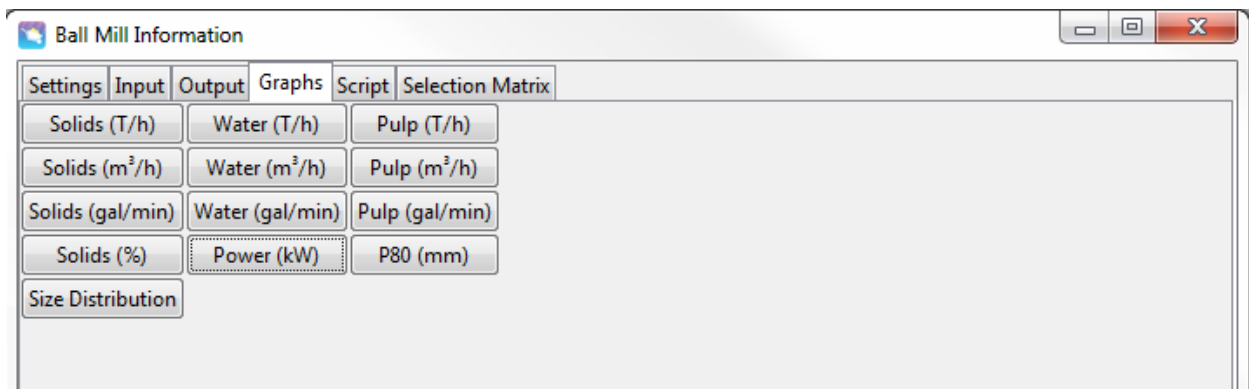

Similar to the feed, the user can change the RPM of ball mill by dragging the slider on the ball mill icon left or right.

“Selection Matrix” allows the user to choose which size range they want to break more or less.

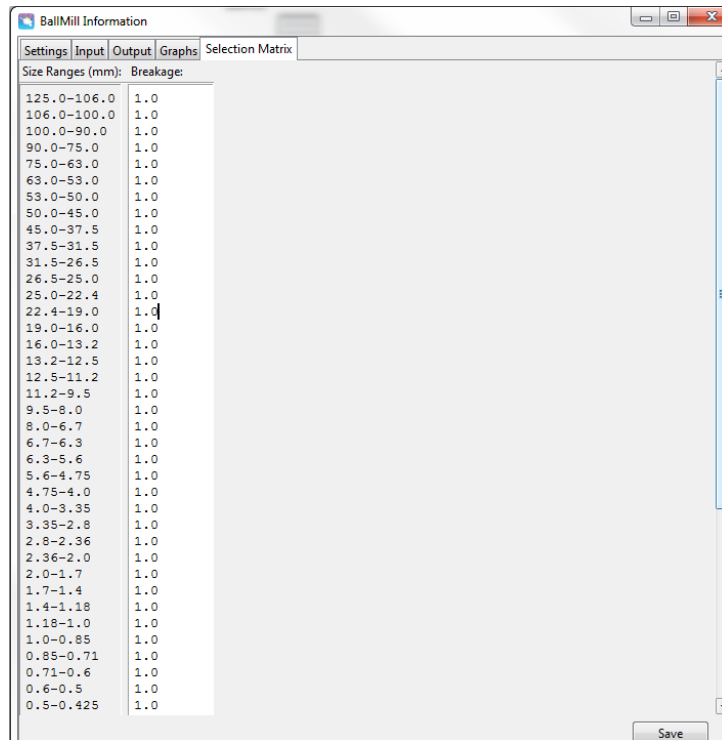

2.3 Semi Autogenous Mill (SAG Mill)

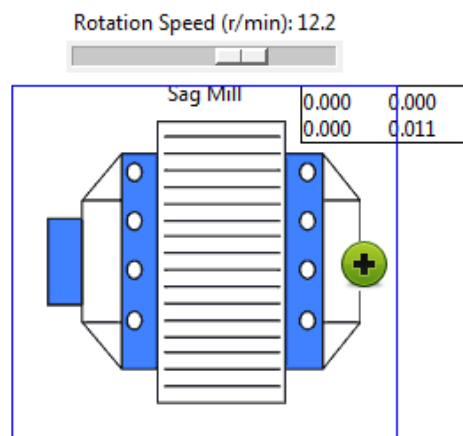

SAG Mill Icon

To change the SAG Mill settings, the user can right click on the “SAG Mill” icon. A menu will pop up with the title “Mill Settings”.

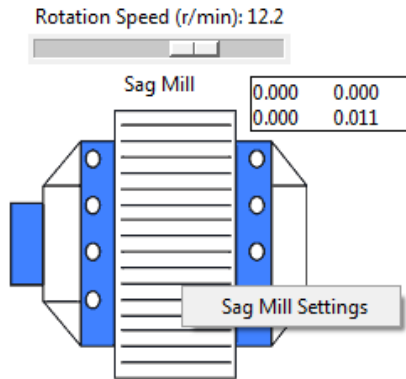

On clicking the icon, a tab containing all the parameters will open.

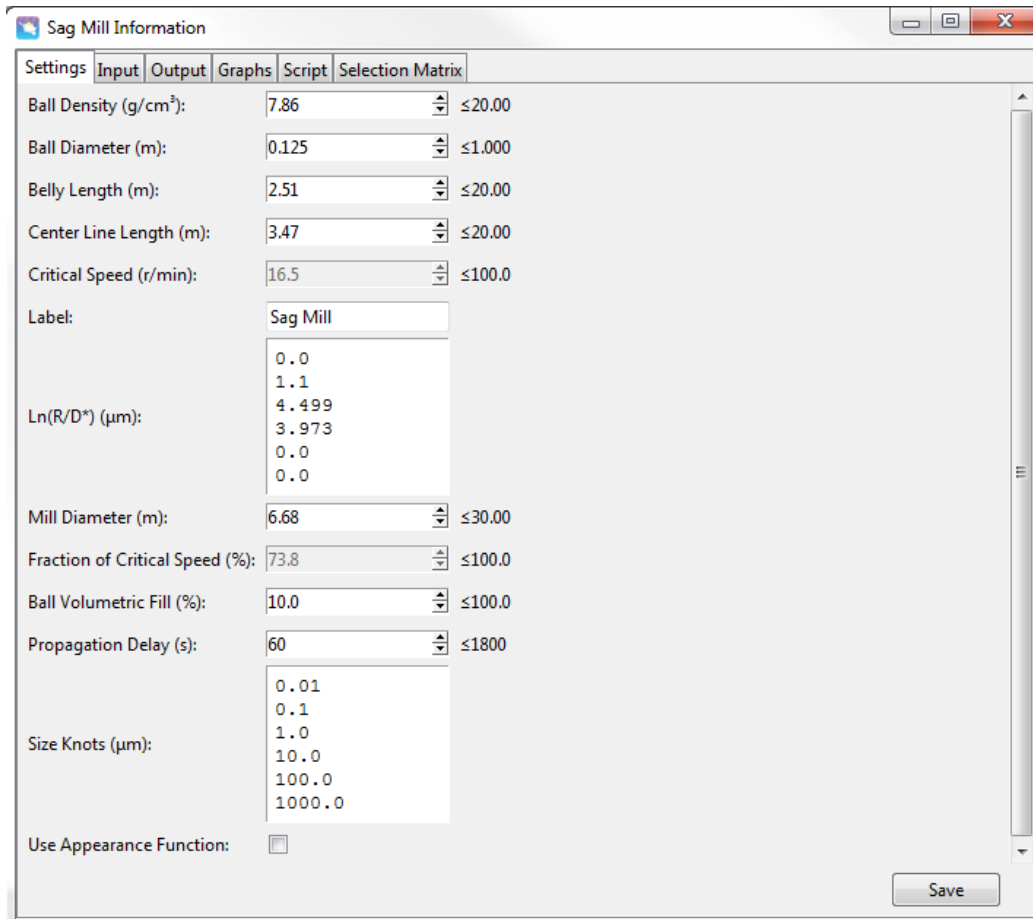

“Propagation delay” means the delay in output of SAG mill. 1 step delay is equal to 1 iteration. So if a user opts for larger step delay, the output of SAG mill will take longer to display.

“Appearance Function” relates to the retention of material in the SAG mill. In the ideal situation, there will be no retention of material in the ball mill. If the user wants no retention of material in

the SAG mill, then they can check the “Use appearance Function” box.

The variables for the SAG mill include the ball density (in gm/cm³), ball diameter (in meter), belly length (in meter), center line length (in meter), mill diameter (in meter), volume of balls (in %), and rotation speed (in RPM).

After making all the changes, the user has to save them by clicking on the “Save” button.

Similar to the feed, the user can change the RPM of SAG mill by dragging the slider on the SAG mii icon left or right.

Size Range (mm)	Flow (T/h)	Flow (%)	Attributes	Value
137.0 - 123.0	0.000	0.000	Solids Density (SG)	2.65
123.0 - 111.0	0.000	0.000	Solids Flow (T/h)	0.00
111.0 - 100.0	0.000	0.000	Solids Flow (m ³ /h)	0.00
100.0 - 90.00	0.000	0.000	Solids Flow (gal/min)	0.00
90.00 - 81.00	0.000	0.000	Solids Proportion (%)	100.00
81.00 - 72.90	0.000	0.000	Water Density (SG)	1.00
72.90 - 65.60	0.000	0.000	Water Flow (T/h)	0.00
65.60 - 59.00	0.000	0.000	Water Flow (m ³ /h)	0.00
59.00 - 53.10	0.000	0.000	Water Flow (gal/min)	0.00
53.10 - 47.80	0.000	0.000	Pulp Density (SG)	2.65
47.80 - 43.00	0.000	0.000	Pulp Flow (T/h)	0.00
43.00 - 38.70	0.000	0.000	Pulp Flow (m ³ /h)	0.00
38.70 - 34.90	0.000	0.000	Pulp Flow (gal/min)	0.00
34.90 - 31.40	0.000	0.000	D80 RR New (mm)	0.01
31.40 - 28.20	0.000	0.000	D80 RR Old (mm)	0.01
28.20 - 25.40	0.000	0.000	D80 GGS (mm)	0.01
25.40 - 22.90	0.000	0.000	D80 Linear (mm)	0.01
22.90 - 20.60	0.000	0.000	Power (kW)	0.00

Size Range (mm)	Flow (T/h)	Flow (%)	Attributes	Value
137.0 - 123.0	0.000	0.000	Solids Density (SG)	2.65
123.0 - 111.0	0.000	0.000	Solids Flow (T/h)	0.00
111.0 - 100.0	0.000	0.000	Solids Flow (m ³ /h)	0.00
100.0 - 90.00	0.000	0.000	Solids Flow (gal/min)	0.00
90.00 - 81.00	0.000	0.000	Solids Proportion (%)	100.00
81.00 - 72.90	0.000	0.000	Water Density (SG)	1.00
72.90 - 65.60	0.000	0.000	Water Flow (T/h)	0.00
65.60 - 59.00	0.000	0.000	Water Flow (m ³ /h)	0.00
59.00 - 53.10	0.000	0.000	Water Flow (gal/min)	0.00
53.10 - 47.80	0.000	0.000	Pulp Density (SG)	2.65
47.80 - 43.00	0.000	0.000	Pulp Flow (T/h)	0.00
43.00 - 38.70	0.000	0.000	Pulp Flow (m ³ /h)	0.00
38.70 - 34.90	0.000	0.000	Pulp Flow (gal/min)	0.00
34.90 - 31.40	0.000	0.000	D80 RR New (mm)	0.01
31.40 - 28.20	0.000	0.000	D80 RR Old (mm)	0.01
28.20 - 25.40	0.000	0.000	D80 GGS (mm)	0.01
25.40 - 22.90	0.000	0.000	D80 Linear (mm)	0.01
22.90 - 20.60	0.000	0.000	Power (kW)	0.00

The previous two tabs show the difference between the weight distribution in different size ranges for a particular input and output of a SAG mill.

The “Graph” tab will show the different graphs.

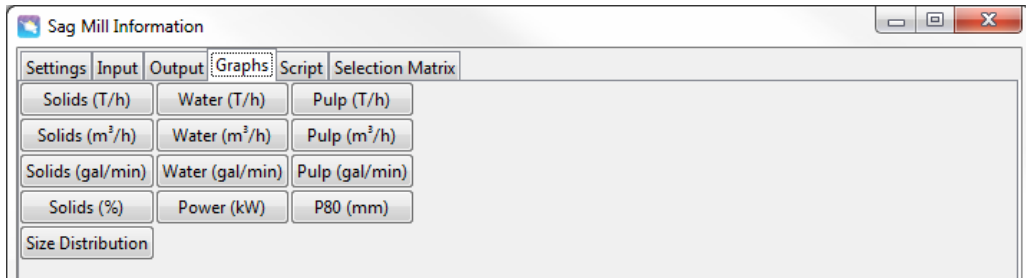

Similar to the previous unit operations, the user can choose to upload their own script and selection matrix.

2.4 Hydrocyclone

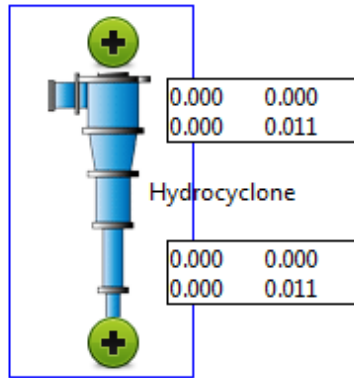

Hydrocyclone Icon

The hydrocyclone will have two outlets and one inlet. The two outlets are overflow and underflow while one inlet is feed.

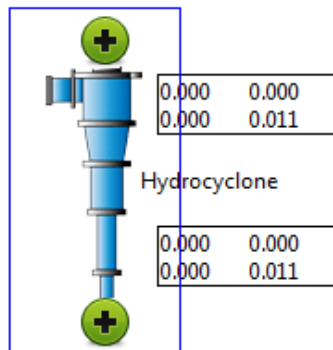

Hydrocyclone icon showing two outlets

To change the hydrocyclone settings, the user can right click on the “Hydrocyclone” icon. A menu will pop up with the title “Hydrocyclone Settings”.

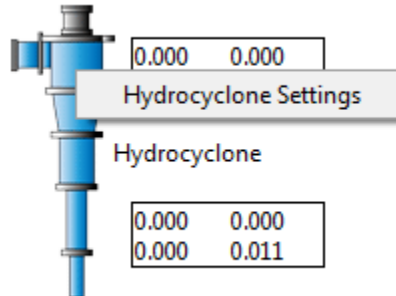

On clicking the icon, a tab containing all the parameters will open.

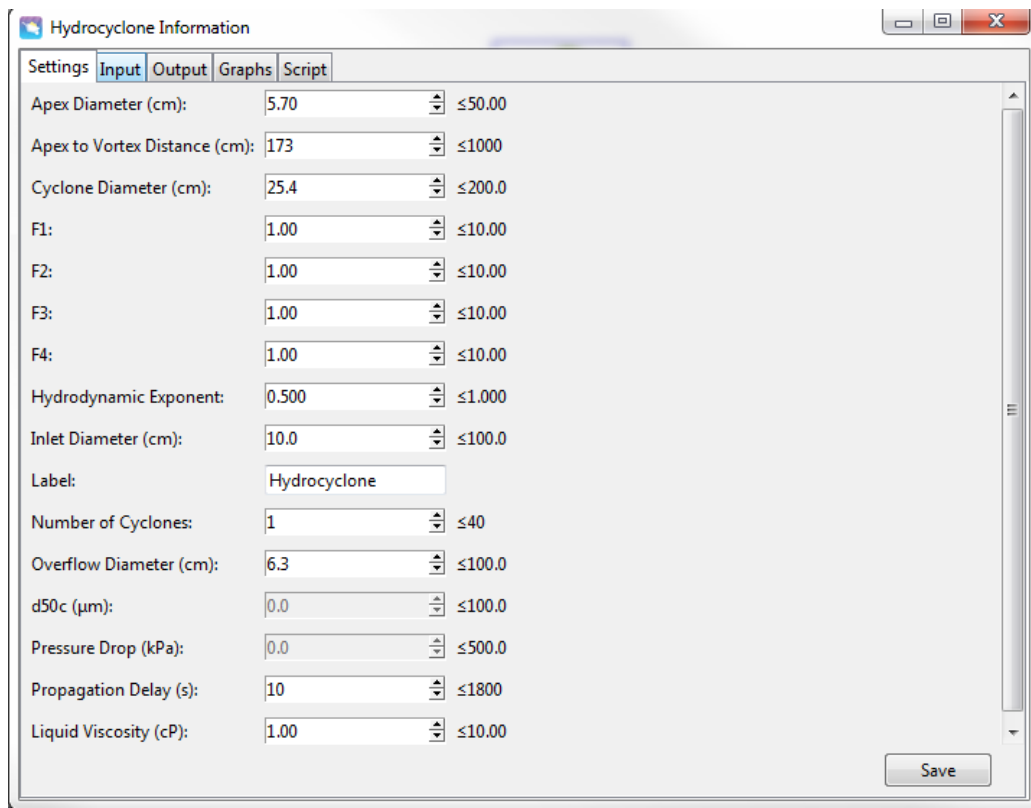

The variables for the hydrocyclone include the apex diameter (in centimeter), distance between Apex and Vortex (in centimeter), cyclone diameter (in centimeter), hydrodynamic exponent, inlet diameter (in centimeter), number of hydrocyclone, overflow diameter (in in centimeter), propagation delay and liquid viscosity (in centipoise).

The user can change the parameters by editing the values in appropriate boxes. To save these changes, the user has to click on the “Save” button.

In a circuit, the hydrocyclone is always paired with the sump pump to provide water to it. Without the addition of sump pump, the hydrocyclone will give wrong output.

Size Range (mm)	Flow (T/h)	Flow (%)	Attributes	Value
137.0 - 123.0	0.000	0.000	Solids Density (SG)	2.65
123.0 - 111.0	0.000	0.000	Solids Flow (T/h)	0.00
111.0 - 100.0	0.000	0.000	Solids Flow (m³/h)	0.00
100.0 - 90.00	0.000	0.000	Solids Flow (gal/min)	0.00
90.00 - 81.00	0.000	0.000	Solids Proportion (%)	100.00
81.00 - 72.90	0.000	0.000	Water Density (SG)	1.00
72.90 - 65.60	0.000	0.000	Water Flow (T/h)	0.00
65.60 - 59.00	0.000	0.000	Water Flow (m³/h)	0.00
59.00 - 53.10	0.000	0.000	Water Flow (gal/min)	0.00
53.10 - 47.80	0.000	0.000	Pulp Density (SG)	2.65
47.80 - 43.00	0.000	0.000	Pulp Flow (T/h)	0.00
43.00 - 38.70	0.000	0.000	Pulp Flow (m³/h)	0.00
38.70 - 34.90	0.000	0.000	Pulp Flow (gal/min)	0.00
34.90 - 31.40	0.000	0.000	D80 RR New (mm)	0.01
31.40 - 28.20	0.000	0.000	D80 RR Old (mm)	0.01
28.20 - 25.40	0.000	0.000	D80 GGS (mm)	0.01
25.40 - 22.90	0.000	0.000	D80 Linear (mm)	0.01
22.90 - 20.60	0.000	0.000	Power (kW)	0.00

Underflow:				
Size Range (mm)	Flow (T/h)	Flow (%)	Attributes	Value
137.0 - 123.0	0.000	0.000	Solids Density (SG)	2.65
123.0 - 111.0	0.000	0.000	Solids Flow (T/h)	0.00
111.0 - 100.0	0.000	0.000	Solids Flow (m³/h)	0.00
100.0 - 90.00	0.000	0.000	Solids Flow (gal/min)	0.00
90.00 - 81.00	0.000	0.000	Solids Proportion (%)	100.00
81.00 - 72.90	0.000	0.000	Water Density (SG)	1.00
72.90 - 65.60	0.000	0.000	Water Flow (T/h)	0.00
65.60 - 59.00	0.000	0.000	Water Flow (m³/h)	0.00
59.00 - 53.10	0.000	0.000	Water Flow (gal/min)	0.00
53.10 - 47.80	0.000	0.000	Pulp Density (SG)	2.65
47.80 - 43.00	0.000	0.000	Pulp Flow (T/h)	0.00
43.00 - 38.70	0.000	0.000	Pulp Flow (m³/h)	0.00
38.70 - 34.90	0.000	0.000	Pulp Flow (gal/min)	0.00
34.90 - 31.40	0.000	0.000	D80 RR New (mm)	0.01
31.40 - 28.20	0.000	0.000	D80 RR Old (mm)	0.01
28.20 - 25.40	0.000	0.000	D80 GGS (mm)	0.01
25.40 - 22.90	0.000	0.000	D80 Linear (mm)	0.01
22.90 - 20.60	0.000	0.000	Power (kW)	0.00
Overflow:				
Size Range (mm)	Flow (T/h)	Flow (%)	Attributes	Value
137.0 - 123.0	0.000	0.000	Solids Density (SG)	2.65

Size Range (mm)	Flow (T/h)	Flow (%)	Attributes	Value
137.0 - 123.0	0.000	0.000	Solids Density (SG)	2.65
123.0 - 111.0	0.000	0.000	Solids Flow (T/h)	0.00
111.0 - 100.0	0.000	0.000	Solids Flow (m ³ /h)	0.00
100.0 - 90.00	0.000	0.000	Solids Flow (gal/min)	0.00
90.00 - 81.00	0.000	0.000	Solids Proportion (%)	100.00
81.00 - 72.90	0.000	0.000	Water Density (SG)	1.00
72.90 - 65.60	0.000	0.000	Water Flow (T/h)	0.00
65.60 - 59.00	0.000	0.000	Water Flow (m ³ /h)	0.00
59.00 - 53.10	0.000	0.000	Water Flow (gal/min)	0.00
53.10 - 47.80	0.000	0.000	Pulp Density (SG)	2.65
47.80 - 43.00	0.000	0.000	Pulp Flow (T/h)	0.00
43.00 - 38.70	0.000	0.000	Pulp Flow (m ³ /h)	0.00
38.70 - 34.90	0.000	0.000	Pulp Flow (gal/min)	0.00
34.90 - 31.40	0.000	0.000	D80 RR New (mm)	0.01
31.40 - 28.20	0.000	0.000	D80 RR Old (mm)	0.01
28.20 - 25.40	0.000	0.000	D80 GGS (mm)	0.01
25.40 - 22.90	0.000	0.000	D80 Linear (mm)	0.01
22.90 - 20.60	0.000	0.000	Power (kW)	0.00

The previous three tabs show the input and output of a hydrocyclone. The user can see the output of both the overflow and underflow in the same table.

The above three tabs show the difference between the weight distribution in different size ranges for a particular input and output of a hydrocyclone.

The “Graph” tab will show the different graphs for underflow and overflow.

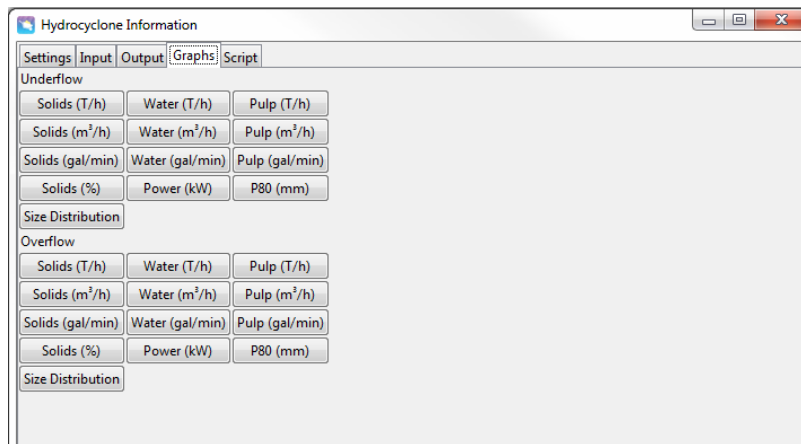

The hydrocyclone is a very sensitive equipment and minor changes in the parameters can affect the performance. Below, the range of each parameter is mentioned where the hydrocyclone will work.

Inlet area: 7% of cross section of cylindrical chamber

Vortex finder area: 30% of cyclone diameter

Apex diameter: 10-35% of the cyclone diameter

Cone angle: 10°-20°

2.5 Sump Pump

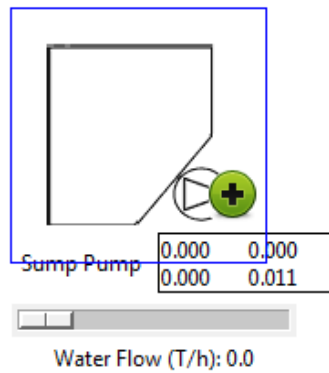

Sump Pump Icon

To change the sump pump settings, the user can right click on the “SumpPump” icon. A menu will pop up with the title “SumpPump Settings”.

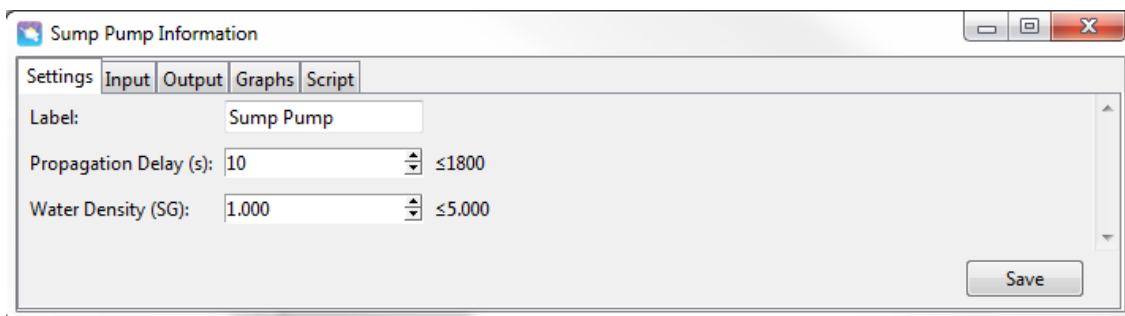
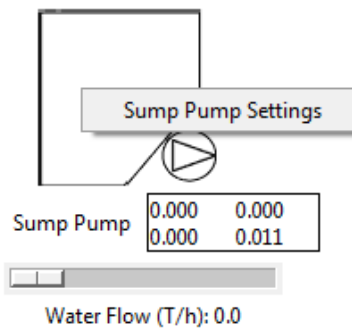

Here, the user has the option to change propagation delay, tonnage of water and the specific gravity of water. Changing specific gravity of water implies that the sump pump is now pumping a liquid that is not water.

Screenshot of the 'Sump Pump Information' window with the 'Settings' tab selected. The window displays a table with columns for Size Range (mm), Flow (T/h), Flow (%), Attributes, and Value.

Size Range (mm)	Flow (T/h)	Flow (%)	Attributes	Value
137.0 - 123.0	0.000	0.000	Solids Density (SG)	2.65
123.0 - 111.0	0.000	0.000	Solids Flow (T/h)	0.00
111.0 - 100.0	0.000	0.000	Solids Flow (m³/h)	0.00
100.0 - 90.00	0.000	0.000	Solids Flow (gal/min)	0.00
90.00 - 81.00	0.000	0.000	Solids Proportion (%)	100.00
81.00 - 72.90	0.000	0.000	Water Density (SG)	1.00
72.90 - 65.60	0.000	0.000	Water Flow (T/h)	0.00
65.60 - 59.00	0.000	0.000	Water Flow (m³/h)	0.00
59.00 - 53.10	0.000	0.000	Water Flow (gal/min)	0.00
53.10 - 47.80	0.000	0.000	Pulp Density (SG)	2.65
47.80 - 43.00	0.000	0.000	Pulp Flow (T/h)	0.00
43.00 - 38.70	0.000	0.000	Pulp Flow (m³/h)	0.00
38.70 - 34.90	0.000	0.000	Pulp Flow (gal/min)	0.00
34.90 - 31.40	0.000	0.000	D80 RR New (mm)	0.01
31.40 - 28.20	0.000	0.000	D80 RR Old (mm)	0.01
28.20 - 25.40	0.000	0.000	D80 GGS (mm)	0.01
25.40 - 22.90	0.000	0.000	D80 Linear (mm)	0.01
22.90 - 20.60	0.000	0.000	Power (kW)	0.00

Screenshot of the 'Sump Pump Information' window with the 'Output' tab selected. The window displays a table with columns for Size Range (mm), Flow (T/h), Flow (%), Attributes, and Value. The 'O:' label is visible above the table.

O: Size Range (mm)	Flow (T/h)	Flow (%)	Attributes	Value
137.0 - 123.0	0.000	0.000	Solids Density (SG)	2.65
123.0 - 111.0	0.000	0.000	Solids Flow (T/h)	0.00
111.0 - 100.0	0.000	0.000	Solids Flow (m³/h)	0.00
100.0 - 90.00	0.000	0.000	Solids Flow (gal/min)	0.00
90.00 - 81.00	0.000	0.000	Solids Proportion (%)	100.00
81.00 - 72.90	0.000	0.000	Water Density (SG)	1.00
72.90 - 65.60	0.000	0.000	Water Flow (T/h)	0.00
65.60 - 59.00	0.000	0.000	Water Flow (m³/h)	0.00
59.00 - 53.10	0.000	0.000	Water Flow (gal/min)	0.00
53.10 - 47.80	0.000	0.000	Pulp Density (SG)	2.65
47.80 - 43.00	0.000	0.000	Pulp Flow (T/h)	0.00
43.00 - 38.70	0.000	0.000	Pulp Flow (m³/h)	0.00
38.70 - 34.90	0.000	0.000	Pulp Flow (gal/min)	0.00
34.90 - 31.40	0.000	0.000	D80 RR New (mm)	0.01
31.40 - 28.20	0.000	0.000	D80 RR Old (mm)	0.01
28.20 - 25.40	0.000	0.000	D80 GGS (mm)	0.01
25.40 - 22.90	0.000	0.000	D80 Linear (mm)	0.01
22.90 - 20.60	0.000	0.000	Power (kW)	0.00

As the sump pump is not a separate unit process, the output and input tabs will show the same data. The sump pump is there only to add water to the existing circuit parameters. It is used in conjunction with hydrocyclone.

2.6 Screens

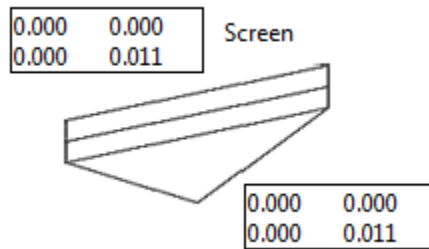

Screen Icon

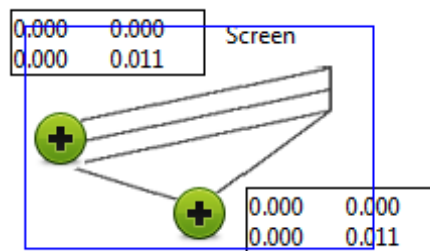

Just like the hydrocyclone, the screen has two outputs, namely, overflow and underflow.

To change the screen settings, the user can right click on the screen icon and then click on the “Screen Settings” button.

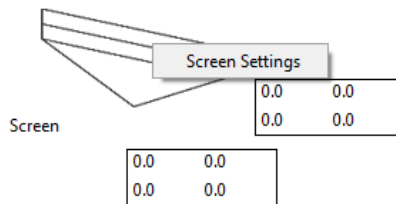

The following window opens after clicking on the “Screen Settings”.

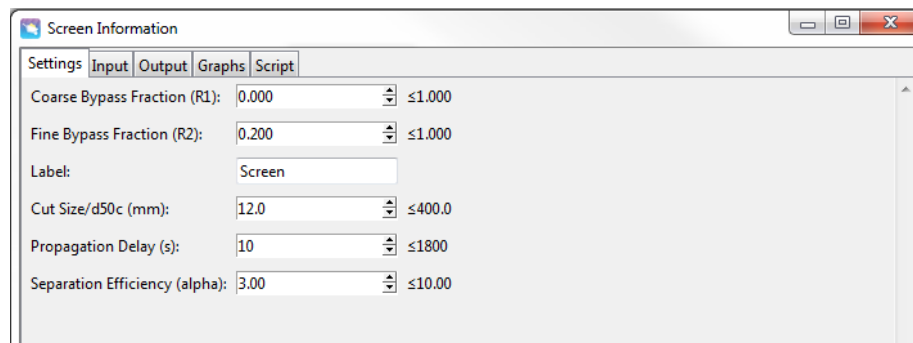

Here, the user has the option of setting their own coarse bypass fraction (R1), fine bypass fraction (R2), cut size (d50c in mm), propagation delay and separation efficiency (α).

Size Range (mm)	Flow (T/h)	Flow (%)	Attributes	Value
137.0 - 123.0	0.000	0.000	Solids Density (SG)	2.65
123.0 - 111.0	0.000	0.000	Solids Flow (T/h)	0.00
111.0 - 100.0	0.000	0.000	Solids Flow (m³/h)	0.00
100.0 - 90.00	0.000	0.000	Solids Flow (gal/min)	0.00
90.00 - 81.00	0.000	0.000	Solids Proportion (%)	100.00
81.00 - 72.90	0.000	0.000	Water Density (SG)	1.00
72.90 - 65.60	0.000	0.000	Water Flow (T/h)	0.00
65.60 - 59.00	0.000	0.000	Water Flow (m³/h)	0.00
59.00 - 53.10	0.000	0.000	Water Flow (gal/min)	0.00
53.10 - 47.80	0.000	0.000	Pulp Density (SG)	2.65
47.80 - 43.00	0.000	0.000	Pulp Flow (T/h)	0.00
43.00 - 38.70	0.000	0.000	Pulp Flow (m³/h)	0.00
38.70 - 34.90	0.000	0.000	Pulp Flow (gal/min)	0.00
34.90 - 31.40	0.000	0.000	D80 RR New (mm)	0.01
31.40 - 28.20	0.000	0.000	D80 RR Old (mm)	0.01
28.20 - 25.40	0.000	0.000	D80 GGS (mm)	0.01
25.40 - 22.90	0.000	0.000	D80 Linear (mm)	0.01
22.90 - 20.60	0.000	0.000	Power (kW)	0.00

The above table shows the feed size range and the corresponding tonnage.

Oversize:				
Size Range (mm)	Flow (T/h)	Flow (%)	Attributes	Value
137.0 - 123.0	0.000	0.000	Solids Density (SG)	2.65
123.0 - 111.0	0.000	0.000	Solids Flow (T/h)	0.00
111.0 - 100.0	0.000	0.000	Solids Flow (m³/h)	0.00
100.0 - 90.00	0.000	0.000	Solids Flow (gal/min)	0.00
90.00 - 81.00	0.000	0.000	Solids Proportion (%)	100.00
81.00 - 72.90	0.000	0.000	Water Density (SG)	1.00
72.90 - 65.60	0.000	0.000	Water Flow (T/h)	0.00
65.60 - 59.00	0.000	0.000	Water Flow (m³/h)	0.00
59.00 - 53.10	0.000	0.000	Water Flow (gal/min)	0.00
53.10 - 47.80	0.000	0.000	Pulp Density (SG)	2.65
47.80 - 43.00	0.000	0.000	Pulp Flow (T/h)	0.00
43.00 - 38.70	0.000	0.000	Pulp Flow (m³/h)	0.00
38.70 - 34.90	0.000	0.000	Pulp Flow (gal/min)	0.00
34.90 - 31.40	0.000	0.000	D80 RR New (mm)	0.01
31.40 - 28.20	0.000	0.000	D80 RR Old (mm)	0.01
28.20 - 25.40	0.000	0.000	D80 GGS (mm)	0.01
25.40 - 22.90	0.000	0.000	D80 Linear (mm)	0.01
22.90 - 20.60	0.000	0.000	Power (kW)	0.00
Undersize:				
Size Range (mm)	Flow (T/h)	Flow (%)	Attributes	Value
137.0 - 123.0	0.000	0.000	Solids Density (SG)	2.65
123.0 - 111.0	0.000	0.000	Solids Flow (T/h)	0.00
111.0 - 100.0	0.000	0.000	Solids Flow (m³/h)	0.00
100.0 - 90.00	0.000	0.000	Solids Flow (gal/min)	0.00
90.00 - 81.00	0.000	0.000	Solids Proportion (%)	100.00
81.00 - 72.90	0.000	0.000	Water Density (SG)	1.00
72.90 - 65.60	0.000	0.000	Water Flow (T/h)	0.00
65.60 - 59.00	0.000	0.000	Water Flow (m³/h)	0.00
59.00 - 53.10	0.000	0.000	Water Flow (gal/min)	0.00
53.10 - 47.80	0.000	0.000	Pulp Density (SG)	2.65
47.80 - 43.00	0.000	0.000	Pulp Flow (T/h)	0.00
43.00 - 38.70	0.000	0.000	Pulp Flow (m³/h)	0.00
38.70 - 34.90	0.000	0.000	Pulp Flow (gal/min)	0.00
34.90 - 31.40	0.000	0.000	D80 RR New (mm)	0.01
31.40 - 28.20	0.000	0.000	D80 RR Old (mm)	0.01
28.20 - 25.40	0.000	0.000	D80 GGS (mm)	0.01
25.40 - 22.90	0.000	0.000	D80 Linear (mm)	0.01
22.90 - 20.60	0.000	0.000	Power (kW)	0.00

The table above shows the amount of particles in each size range for overflow and underflow of a screen. Oversize means particles that overflow while undersize means particles that pass through the screen and report to underflow.

The “Graph” tab will show the different graphs.

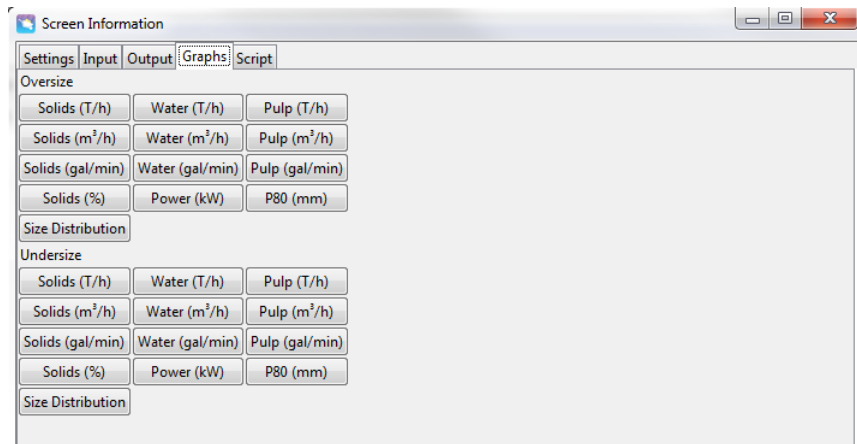

2.7 Splitter 2

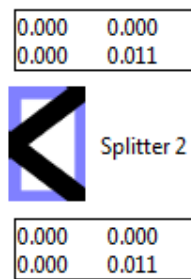

Splitter 2 Icon

Splitter 2 is used to split an input stream into two output streams.

To change the Splitter 2 settings, the user can right click on the splitter icon and then click on the “Splitter 2 Settings” button.

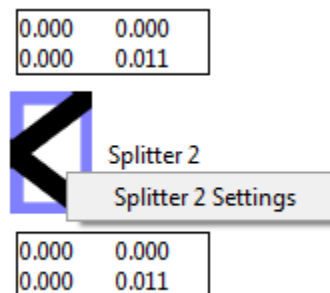

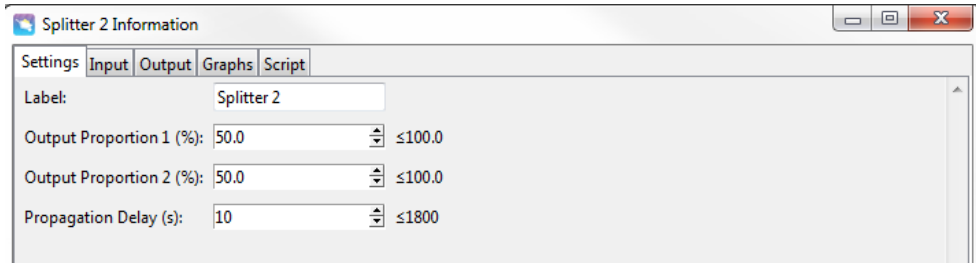

In the above tab, user can select the number of outputs from the splitter and set the respective percentage.

“Propagation delay” means the delay in output of splitter. 1 step delay is equal to 1 iteration. So if a user opts for larger step delay, the output of splitter will take longer to display.

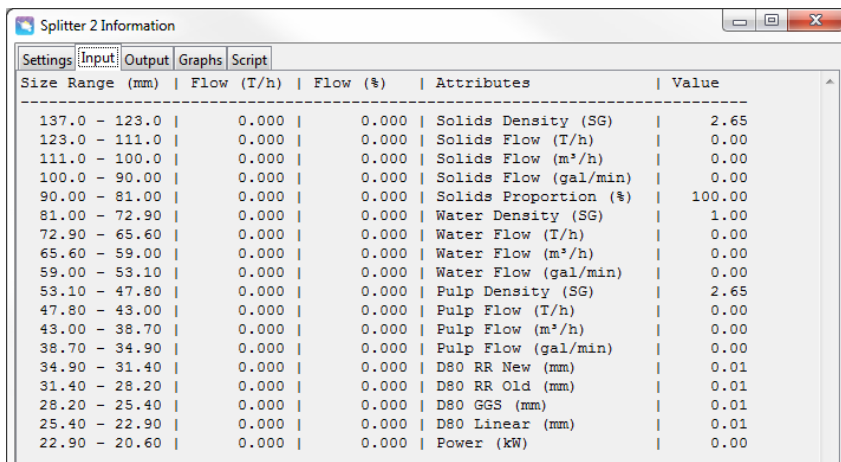

In the “Input” and “Output” tab the user can see the input and output of the splitter.

The splitter does not change the physical properties of the incoming feed. It only splits them into two or more parts.

The user can see the graphs for different outputs by clicking on the “Graph” tab.

2.8 Splitter 4

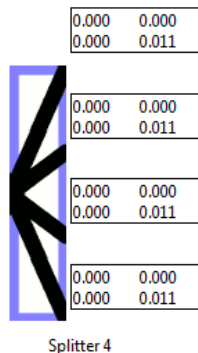

Splitter 4

Splitter 4 Icon

Splitter 4 is used to split an input stream into four output streams.

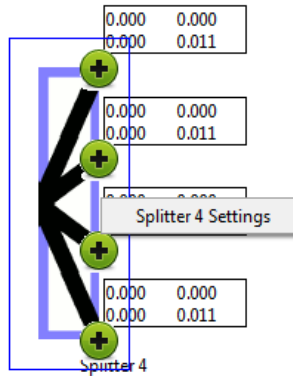

To change the Splitter 4 settings, the user can right click on the splitter icon and then click on the “Splitter 4 Settings” button.

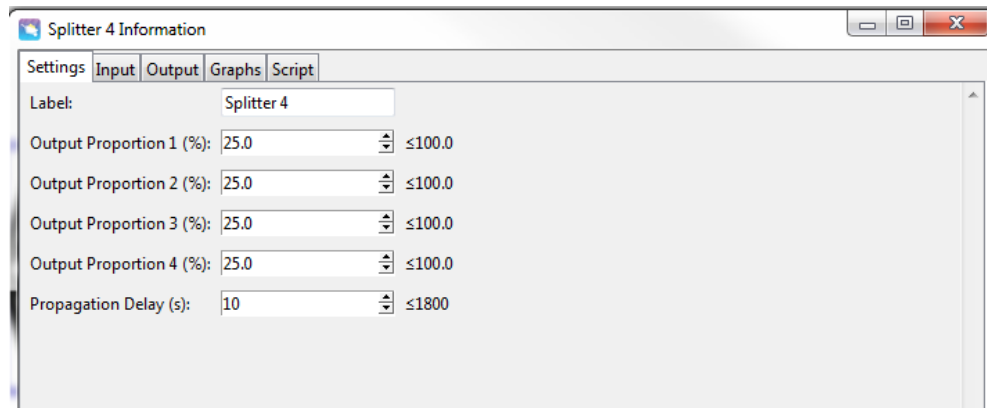

In the above tab, user can select the number of outputs from the splitter and set the respective percentage.

The screenshot shows the 'Splitter 4 Information' dialog box with the 'Input' tab selected. It displays a table of input stream attributes and values.

Size Range (mm)	Flow (T/h)	Flow (%)	Attributes	Value
137.0 - 123.0	0.000	0.000	Solids Density (SG)	2.65
123.0 - 111.0	0.000	0.000	Solids Flow (T/h)	0.00
111.0 - 100.0	0.000	0.000	Solids Flow (m³/h)	0.00
100.0 - 90.00	0.000	0.000	Solids Flow (gal/min)	0.00
90.00 - 81.00	0.000	0.000	Solids Proportion (%)	100.00
81.00 - 72.90	0.000	0.000	Water Density (SG)	1.00
72.90 - 65.60	0.000	0.000	Water Flow (T/h)	0.00
65.60 - 59.00	0.000	0.000	Water Flow (m³/h)	0.00
59.00 - 53.10	0.000	0.000	Water Flow (gal/min)	0.00
53.10 - 47.80	0.000	0.000	Pulp Density (SG)	2.65
47.80 - 43.00	0.000	0.000	Pulp Flow (T/h)	0.00
43.00 - 38.70	0.000	0.000	Pulp Flow (m³/h)	0.00
38.70 - 34.90	0.000	0.000	Pulp Flow (gal/min)	0.00
34.90 - 31.40	0.000	0.000	D80 RR New (mm)	0.01
31.40 - 28.20	0.000	0.000	D80 RR Old (mm)	0.01
28.20 - 25.40	0.000	0.000	D80 GGS (mm)	0.01
25.40 - 22.90	0.000	0.000	D80 Linear (mm)	0.01
22.90 - 20.60	0.000	0.000	Power (kW)	0.00

“Propagation delay” means the delay in output of splitter. 1 step delay is equal to 1 iteration. So if a user opts for larger step delay, the output of splitter will take longer to display.

In the “Input” and “Output” tab the user can see the input and output of the splitter.

The splitter does not change the physical properties of the incoming feed. It only splits them into two or more parts.

The user can see the graphs for different outputs by clicking on the “Graph” tab.

The main use of splitter is to give freedom to the user so that they can split the feed. They can choose to divide the feed and send it to different unit operations and see the results.

2.9 Junction 2

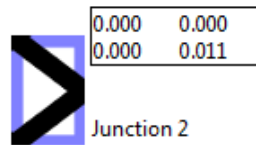

Junction 2 Icon

The use of Junction 2 is to join two different streams.

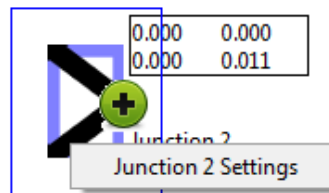

To change the Junction 2 settings, the user can right click on the splitter icon and then click on the “Junction 2 Settings” button.



In the above tab, the user can only change “Propagation Delay”.

2.10 Junction 4

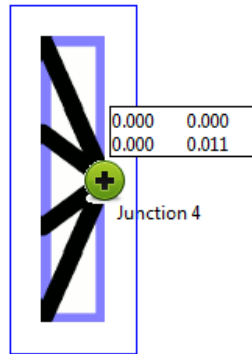

Junction 4 Icon

The use of Junction 4 is to join four different streams.

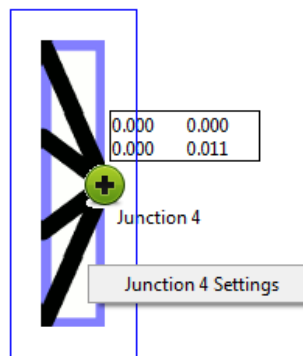

To change the Junction 4 settings, the user can right click on the splitter icon and then click on the “Junction 4 Settings” button.

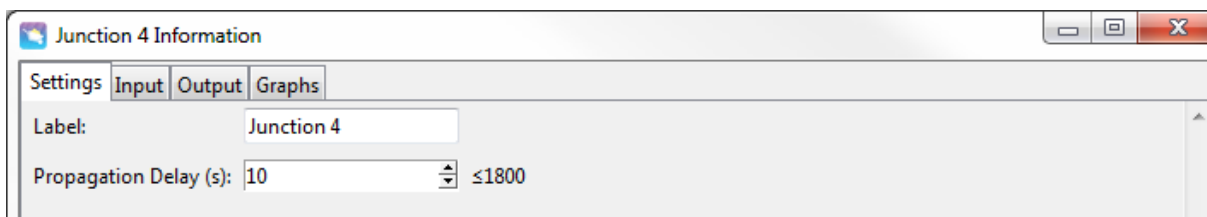

In the above tab, the user can only change “Propagation Delay”.

2.11 Sub Circuit

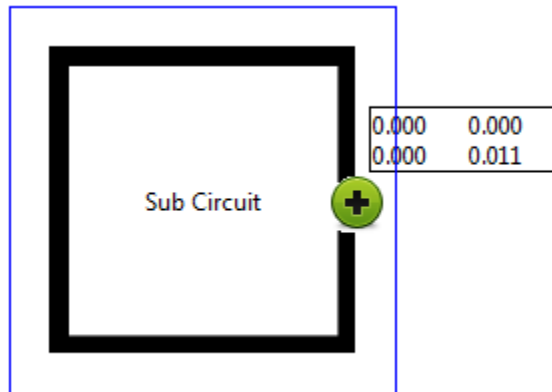

Sub Circuit Icon

The sub circuit is just the extension of normal screen. It gives the user flexibility to expand the circuit or construct complicated circuits.

When the user click on “+”, a new tab opens up as shown below:

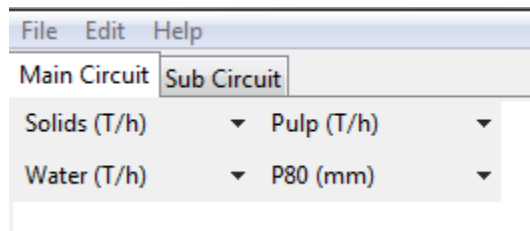

The screenshot below shows the “sub circuit” tab.



2.12 Circuit Output

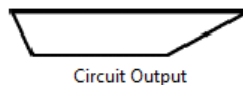

Circuit Output Icon

The circuit output displays the output of the circuit. Similar to the splitter, it does not change any physical properties.

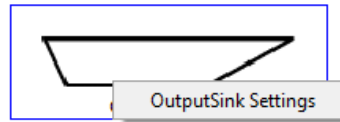

Right clicking on the circuit output icon opens a message box named “OutputSink Settings” from where the user can change the propagation delay.

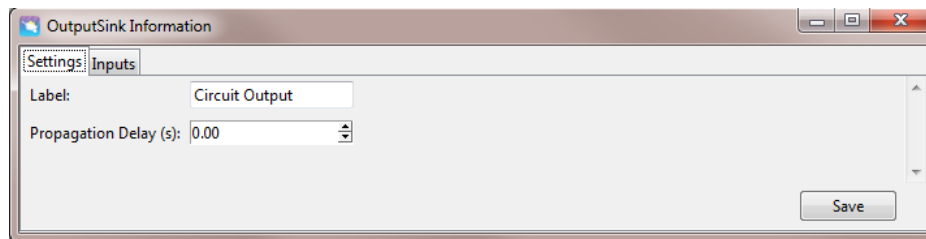

In every unit operation parameter, the maximum permissible values are mentioned. The user should keep the values within that limit.

3. Operation

3.1 Getting Started

1. On running the application the user will see white canvas which serves as a drawing board to draw any flow sheet.

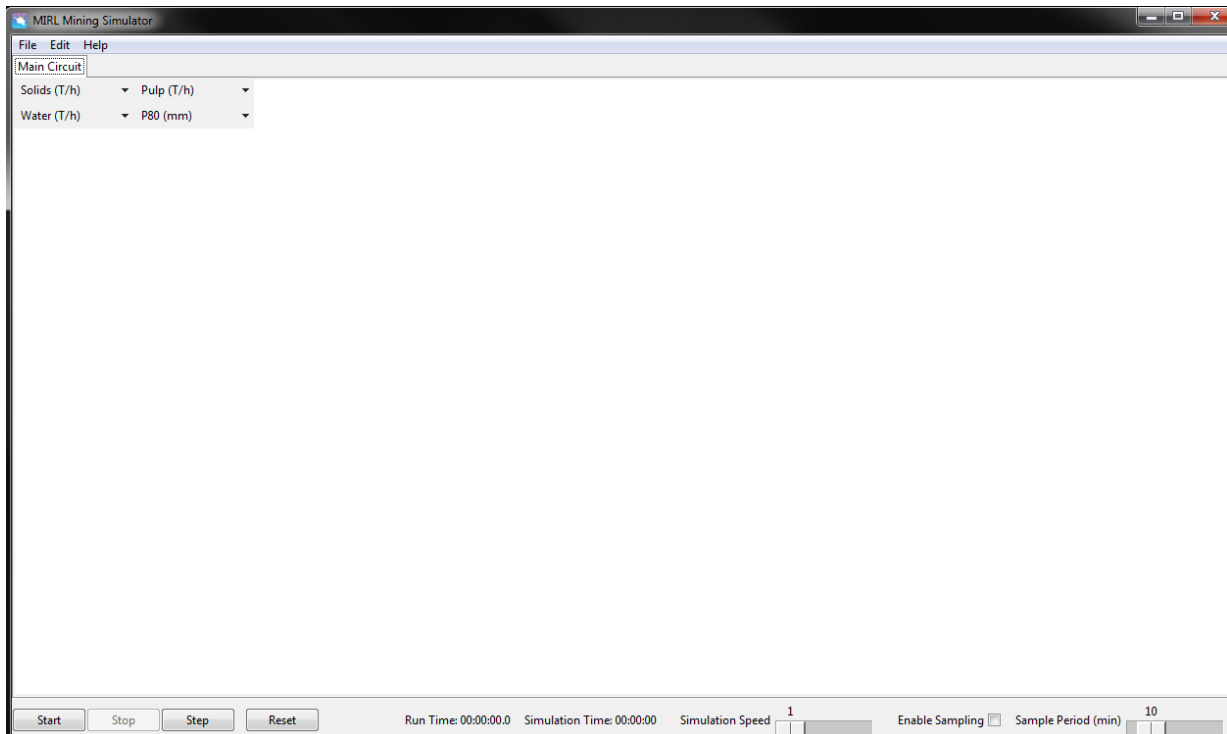

Figure 1: Drawing Canvas

At the bottom right side of the canvas, the user can see two clocks labelled “Run Time” and “Simulation Time”. Run time shows the time since the simulation was started while the simulation time shows the time for which the process runs in real time at a processing plant. The simulation time can be adjusted by dragging the simulation speed slider left or right.

At simulation speed of “1”, 1 second of run time is equivalent to 30 seconds of simulation time while at a simulation speed of “600”, 1 second of run time is equivalent to 30 minutes of simulation time.

The simulator creates “CSV” files which contains data from different unit process at different times. The software gives user the freedom to select a time period to do the sampling. This means if the user selects a sample period of 10 minutes, the simulator will record the data at every 10 minute interval and store it in a csv format.

If the user wishes not to store the data, then they can uncheck the “Enable Sampling” radio button at the bottom right corner of the simulator window.

2. Right click anywhere on the drawing board to access the equipments icon library, you can also access icon library by going to Menu Bar under **Edit > Add**.

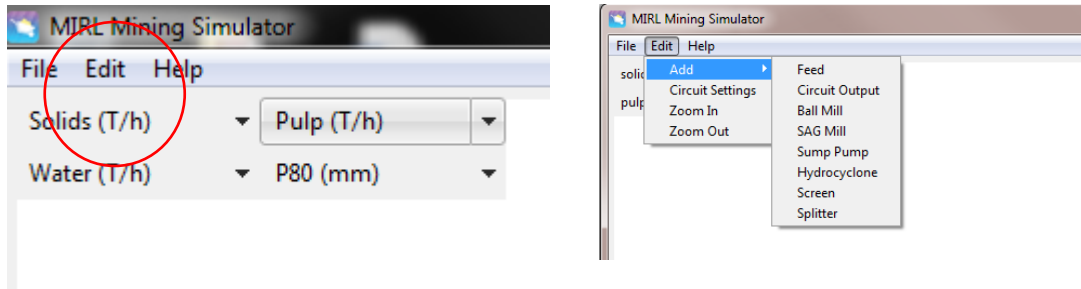

Figure 2: Add Equipment

3. The library consists of equipments of the comminution and classification processes such as grinding, classification and handling units.
4. Select the equipments based on your choice or the flowsheet you are attempting to draw. The version is modular in nature and the order of equipment selection will not affect the simulation results.
5. The equipment icons can be placed anywhere on the drawing canvas by:
 - a. Selecting the icon by clicking on icon you want to move. Upon clicking, the icon gets highlighted and green “+” sign appears (*Figure 1*Figure 3).
 - b. You can also drag multiple icons by pressing **CTRL** and selecting multiple units by clicking on it.

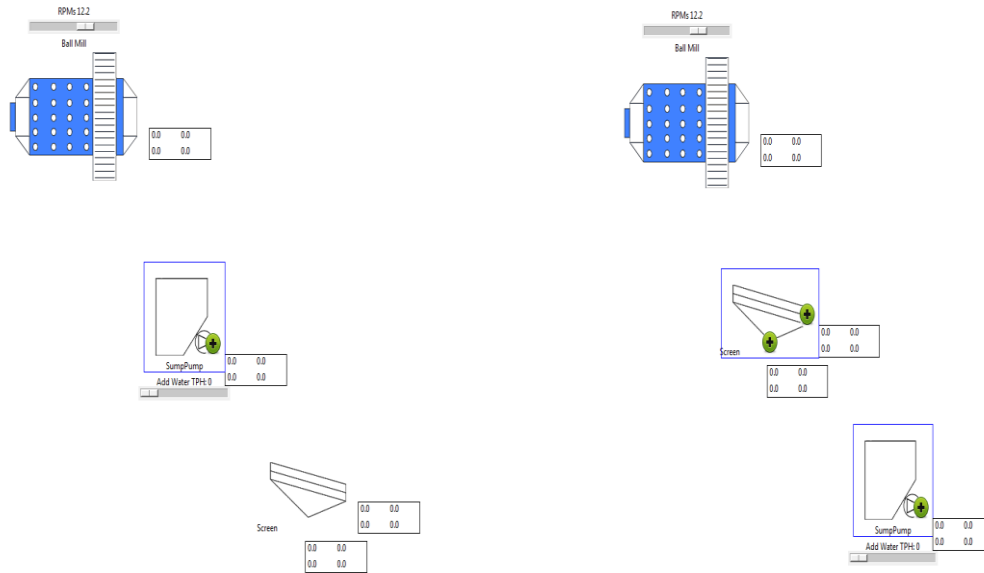
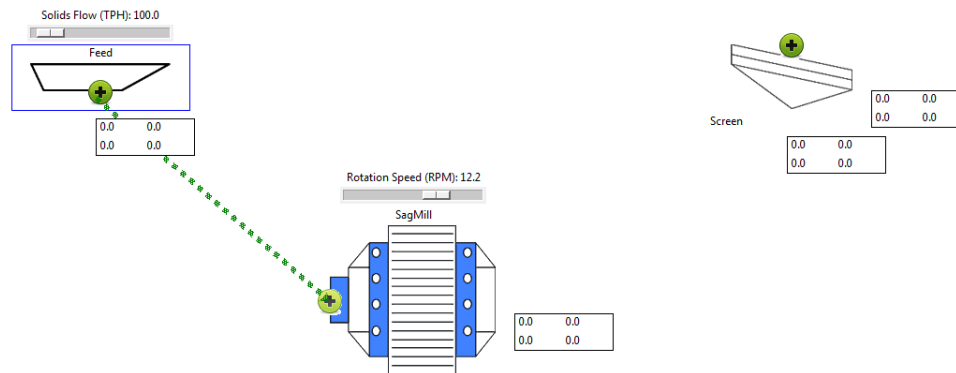

Figure 3: Selection of Equipment Icon, Left: Single Unit, Right: Multiple Unit

6. Once the units are in place it should be interconnected by the stream lines which represents the flow of material (solid, water and slurry) from one equipment to another.
7. The stream line between two equipments can be drawn by selecting the equipment from which the stream line will be originating.
 - i) After selecting equipment icon will be highlighted and “+” sign will appear. Upon clicking the “+” sign, you can see the possibilities of joining the line other units.



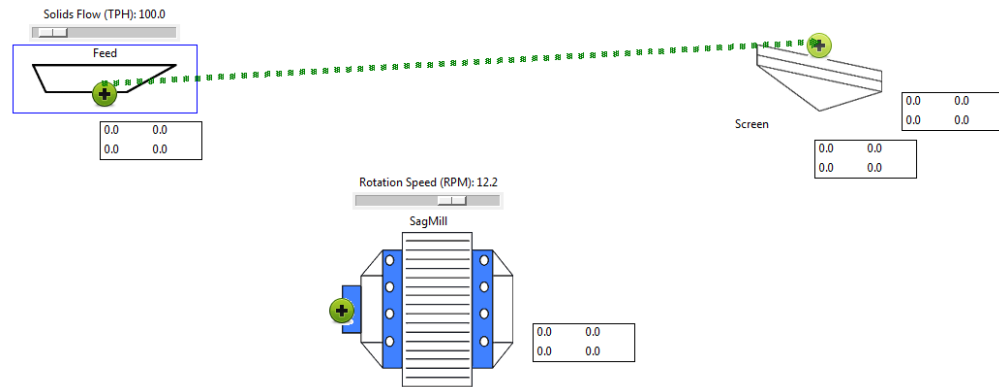

Figure 4: Possibilities for joining stream lines

The dotted line turns green when the pointer reaches another “+” sign which means that the user can connect the stream as shown in the above screenshots.

- ii) Click on the other “+” sign, the stream line will appear itself.

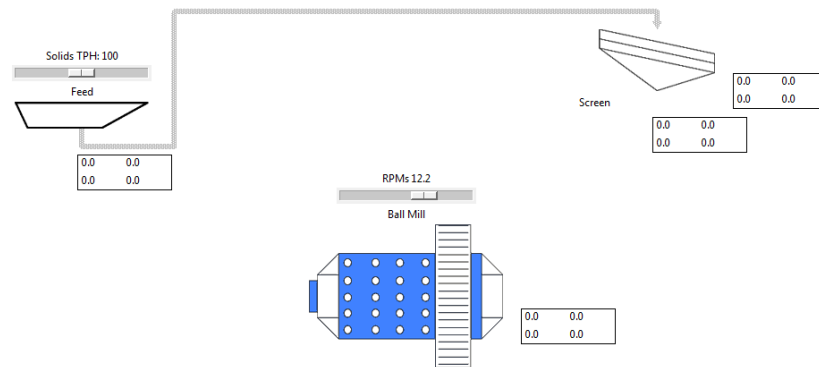

Figure 5: Create Stream Line

- iii) Stream line can be deleted by reselecting them (which turns them into green) and pressing **Delete** button on keyboard.

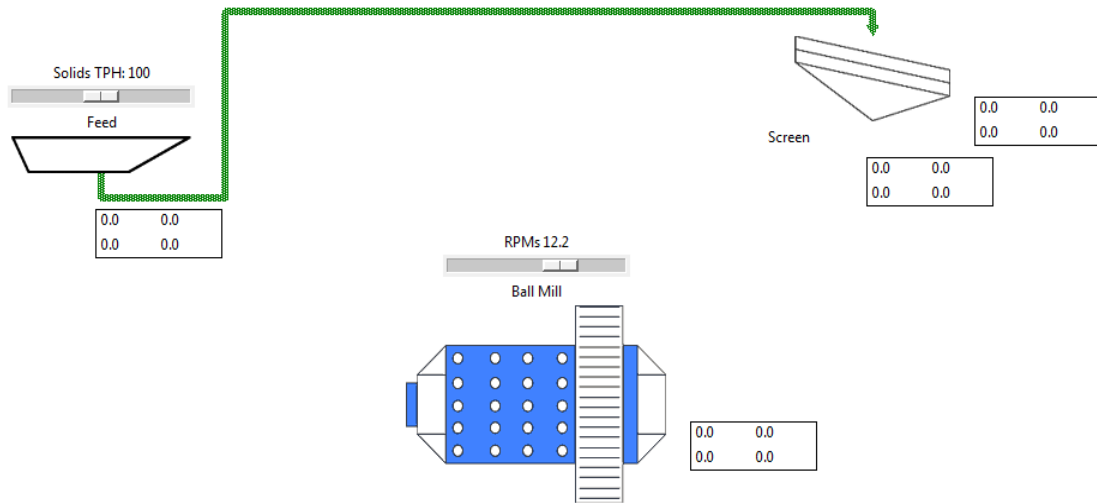

Figure 6: Delete Stream Line

8. Ensure all the equipments are properly connected. The product stream should be connected to circuit output. In case of multiple product, multiple circuit output should be selected (Figure 7).

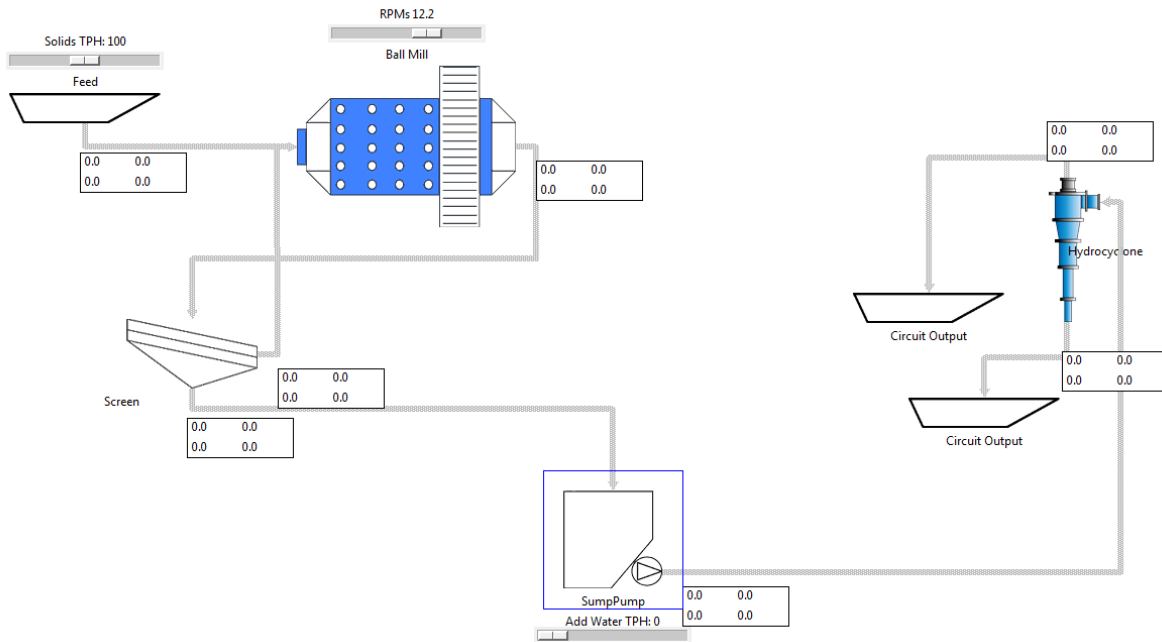
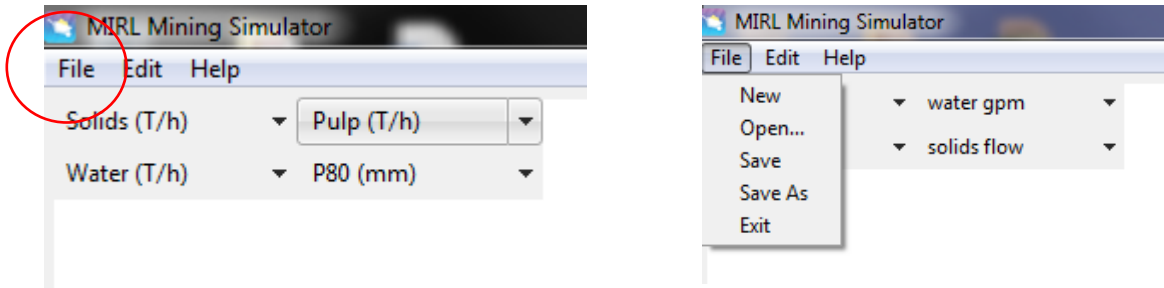

Figure 7: Product Stream

- The flowsheet drawn can be saved as well. The software has the feature to save the flowsheet anytime when the application is running. This can be done by going to Menu Bar and selecting **File > Save** or by using the “**Save As**” function also.



Enter the desired file name of the flowsheet and click save. The flowsheet will be saved with an extension **.sim**.

If the user changes the settings of individual unit processes and saves the flowsheet, it will be saved with an extension **.mirl_scenario**.

3.2 Data

Once the flowsheet is drawn, it requires design and operating data for simulation. This includes dimension of the equipments and operating feed, water and other model parameters.

- The data can be entered by double clicking the equipment icon.
- A dialog box of equipment settings appears, typical example of a ball mill is shown in Figure 8.
- User can enter the design specification by typing in value for a particular process unit or by clicking arrows provided. Default value of parameters are already being provided.
- The ore characteristics data such as particle size distribution and weight distribution can also be changed under circuit setting option.
 - This can be accessed by going to Menu Bar under **Edit > Circuit Settings**.

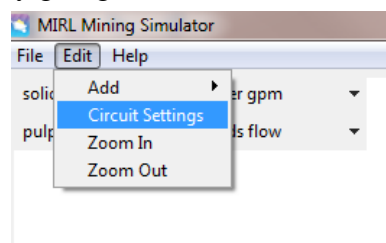

Parameter	Value
Ball Density (g/cm ³):	7.86
Ball Diameter (m):	0.03
Belly Length (m):	8.70
Critical Speed:	18.96
Label:	BallMill
Ln(R/D ³)M:	0.0 1.1 4.499 3.973 0.0 0.
Mill Diameter (m):	5.00
% of Critical Speed:	10.02
Volume % of Balls:	30.00
Propagation Delay (s):	5.00
Rotation Speed (RPM):	1.90
Selection Matrix:	1.0 1.0 1.0 1.0 1.0 1.0 1.0 1.0 1.0 1.0 1.0 1.0 1.0 1.0 1.0 1.0 1.0 1.0 1.0 1.0
Size Knots (mm):	0.0 0.01 2.0 32.0 4096.0
Use Appearance Function:	<input type="checkbox"/>
Use size knots as D5, D50, D80:	<input checked="" type="checkbox"/>

Figure 8: Equipment Setting Dialog for Ball Mill

- b. Enter the size range which you intend to simulate and corresponding particle size distribution will change and then hit save. The size ranges should be in microns.

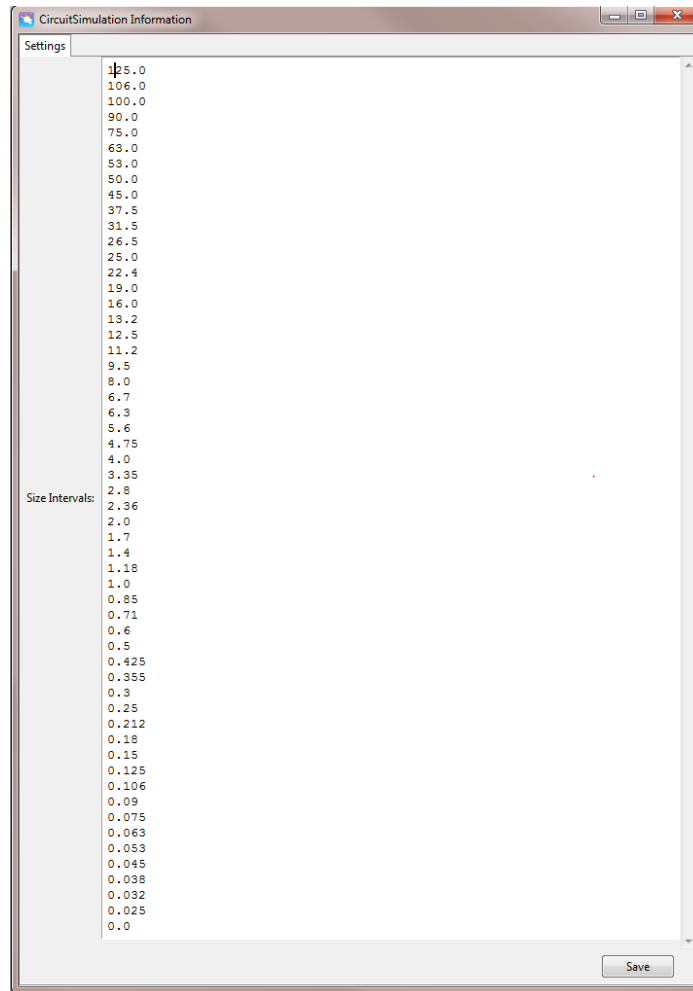

Figure 9: Circuit Settings

3.3 Simulating the flowsheet

After entering the data the simulator is ready to use. The simulation can be started by clicking the **Start** button at the bottom left corner of the interface. Similarly the simulation can be stopped by clicking **Stop** button next to start. On clicking the **Step** button, only one iteration is done. This is helpful in visualizing material flow step by step. **Reset** button resets the circuit to the original state.

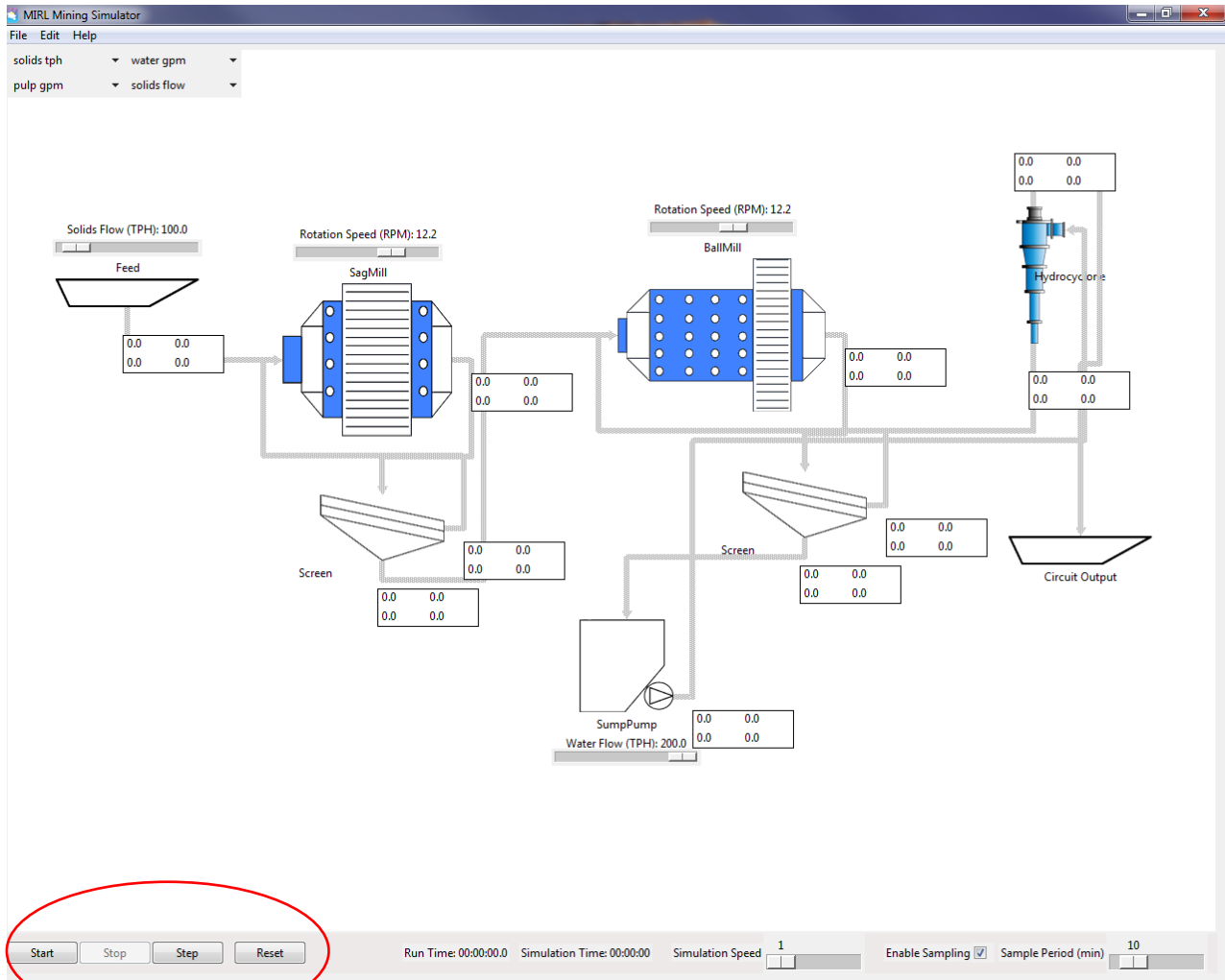
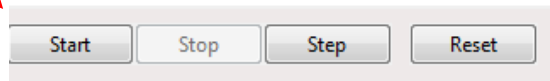
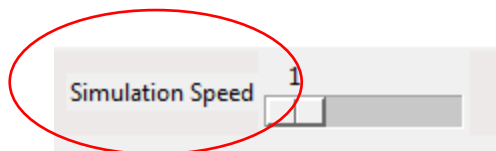

Figure 10: Start/Stop Simulations



The simulator is equipped with the feature to increase and decrease the simulation speed which is the number of iteration or calculation the simulator will be performing in a minute. This can be adjusted through a slider labelled “Simulation Speed” provided at the bottom center of the main drawing canvas.



3.4 Simulation Results

The simulation results and the response of the variables can be viewed in two ways. One is on the equipment basis i.e. the input and output response associated with each equipment while the other is few selected process variables which are/can be allowed displayed on the drawing canvas.

- 1) Input and output response of the variables associated with every equipment can be accessed by double clicking the equipment icon of the equipment. For example in Figure 8 for a ball mill the dialog box contains input and output tabs next to settings tab (Figure 11).

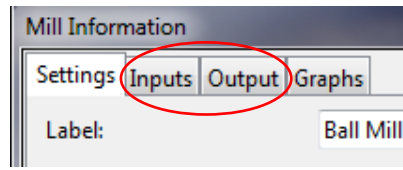

Figure 11: Input-Output Tabs

Figure 12 shows the input data to sag mill at a particular instance of simulation.

 A screenshot of the 'Mill Information' dialog box with the 'Inputs' tab selected. It displays a table with columns for 'Size Range mm', 'Tons', 'Percent', 'Attributes', and 'Value'.

Size Range mm	Tons	Percent	Attributes	Value
125.00 - 106.00	68.074	68.074%	Gravity of Solids (SG)	2.65
106.00 - 100.00	25.986	25.986%	Solids TPH	100.00
100.00 - 90.00	3.252	3.252%	Solids Flow Rate (m ³ /hr)	37.74
90.00 - 75.00	1.680	1.680%	Solids Flow Rate (gpm)	8.57
75.00 - 63.00	0.293	0.293%	Percent Solid	74.1%
63.00 - 53.00	0.510	0.510%	Gravity of Water (SG)	1.00
53.00 - 50.00	0.169	0.169%	Water TPH	35.00
50.00 - 45.00	0.026	0.026%	Water Flow Rate (m ³ /hr)	35.00
45.00 - 37.50	0.003	0.003%	Water Flow Rate (gpm)	7.95
37.50 - 31.50	0.008	0.008%	Gravity of Pulp (SG)	1.86
31.50 - 26.50	0.000	0.000%	Pulp TPH	135.00
26.50 - 25.00	0.000	0.000%	Pulp Flow Rate (m ³ /hr)	72.74
25.00 - 22.40	0.000	0.000%	Pulp Flow Rate (gpm)	16.52
22.40 - 19.00	0.000	0.000%	D80 RR (mm)	115.85
19.00 - 16.00	0.000	0.000%	RR Old	30.39
16.00 - 13.20	0.000	0.000%	D80 GGS (mm)	962.54
13.20 - 12.50	0.000	0.000%	Power (kW)	0.00

Figure 12: Input Data to Ball Mill

- 2) From an operator or an engineer's prospective process variables such as mass flow rate of solids/water or percent solids, mill power, product particle size etc. are monitored at regular interval and are crucial. Hence, the simulator allows these variable to be displayed on main drawing canvas simulator allow to view these variables from the dashboard. These variables are displayed with the stream originating from the equipment (Figure 133).

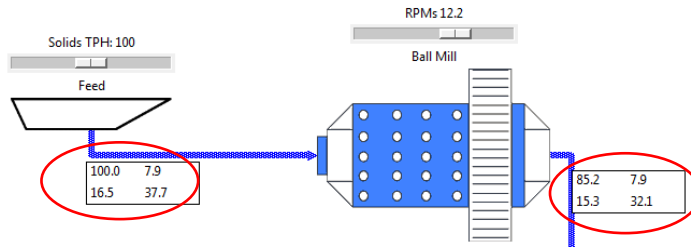

Figure 13: Display of process variables on drawing canvas

Onscreen displays four variables and the choice of the variable can be made by clicking drop down arrows under menu bar (top – left corner below **File** option, **Error! Reference source not found.**).



Figure 14: Choosing variables to be displayed

User can also see the trends of the selected variable and how they change with time during the simulation. For example in Figure 13 the user can see how mill response (power) has changed by clicking on the values displayed.

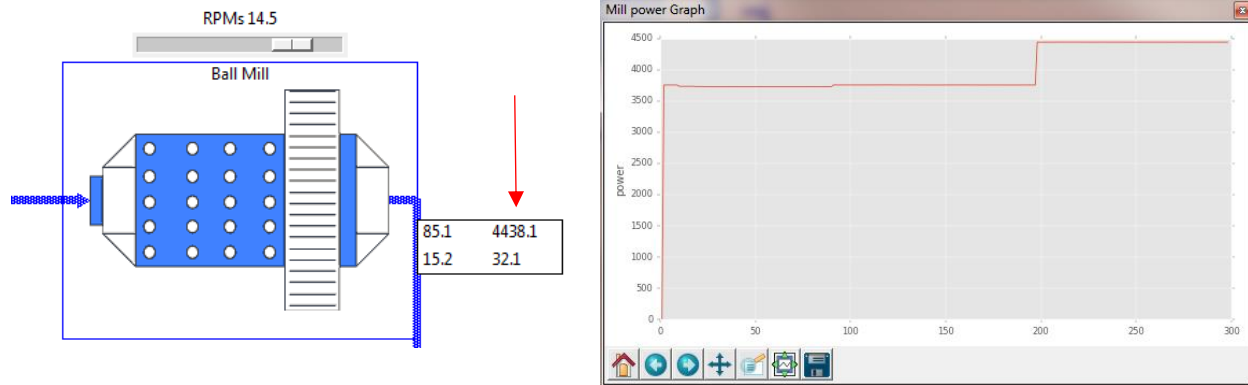

Figure 15: Data Trends

4. Example

People not directly related to Mining/Mineral industry or having less technical knowledge in the field can start with the example flowsheet of a typical grinding circuit of a gold mine operating in Alaska.

4.1 Circuit Description

This flowsheet consists of a feeder, sag mill, ball mill, hydrocyclone and sump-pumps. The sag mill is used for primary grinding, (i.e. it will reduce the size of incoming feed to a certain limit) which is fed by the means of a feeder. The material after being reduced in size in sag mill is discharged into a sump pump. This material is then transferred to ball mill for further size reduction operating in close circuit with a cyclone (Figure).

The ground material is then subjected to classification based on size using cyclone of a particular cut size. The underflow which is the coarse material is sent to ball mill for further size reduction while the overflow is reported to circuit output for subsequent operation.

So our circuit has:

- Solid tonnage, water to sag mill, sag mill discharge sump and cyclone sump as inputs to the circuit which are manipulated variables and can be changed during the simulation.
- The main product of the circuit is cyclone overflow whose size is supposed to be in the range of 60 ± 10 microns.
- Along with that the response of the circuit includes solid mass flow rate, water volumetric flow rate, particle size of the respective streams and cyclone overflow and mill power.

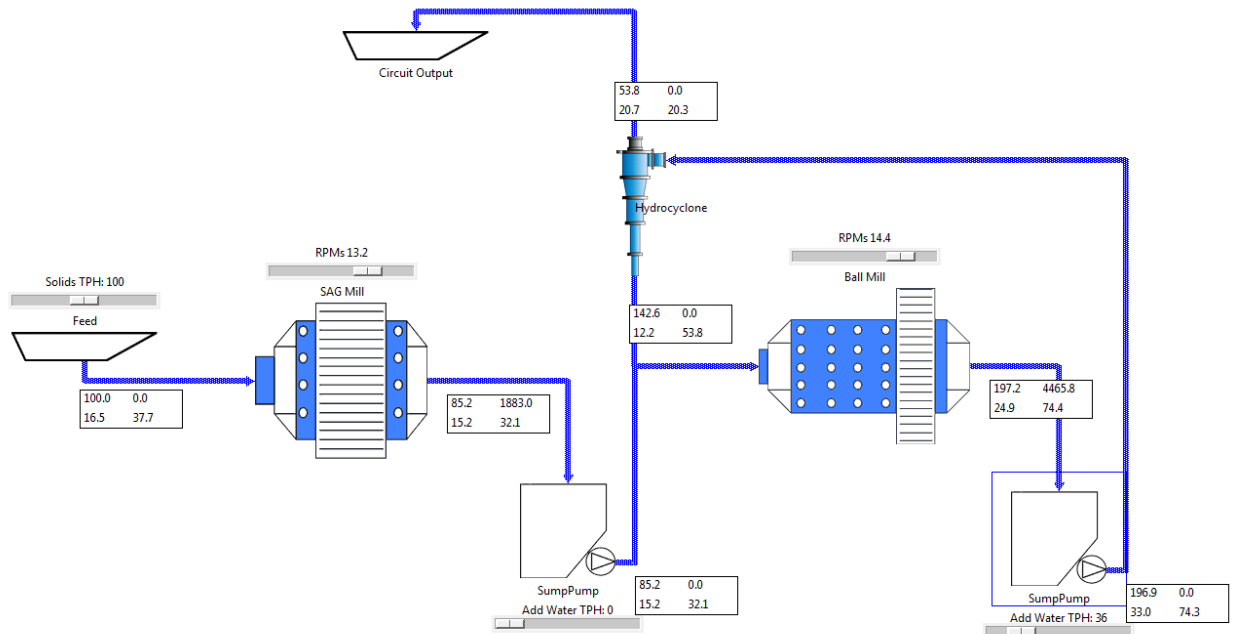

Figure 16: Example Flowsheet

The design and other model parameters are pre-defined.

4.2 Objective

As an operator your objective is to ensure all the response variables which are critical from operational point of view are within acceptable limit ensuring maximum production.

Task:

- Maintain circuit output particle size and maximize solid tph.
- Maintain sag mill power in the range of 500 kW to 550 kW by varying the operating speed (but the maximum permissible limit of the speed is 14.6 rpm which is 80 percent of critical speed).
- Maintain ball power in the range of 570 kW to 630 kW by varying the rpm from 14.3 to a maximum value of 16.8.
- Mill power is also affected by feed tonnage and water addition to the mill. Indicate how the response is affected by changing both.
- Ensure cyclone overflow is in range of 50 to 70 micron. Overgrinding also leads to reduced recovery for downstream processes.
- Less fluctuation is response and input resembles smooth operation.
- Operate sag in a percent solid range of 65-75.

- Ball mill percent solid in the range of 45- 55.

Explain the following

- Effect of cyclone feed specific gravity on overflow size.
- Effect of percent solids on hydrocyclone outputs.

5. Reference

AMIT 135 & AMIT 145 Course Content

<http://mirl.uaf.edu/research/preparing-the-unemployed-for-the-mining-sector-a-taacct-funded-project/>