

# Electrical Level 3



Motor Calculations 26309-14



# Objectives

**When trainees have completed this lesson, they should be able to do the following:**

1. Size branch circuits and feeders for electric motors.
2. Size and select overcurrent protective devices for motors.
3. Size and select overload relays for electric motors.
4. Size and select devices to improve the power factor at motor locations.
5. Size motor short circuit protectors.
6. Size multi-motor branch circuits.
7. Size motor disconnects.

This is a knowledge-based module; there are no Performance Tasks.



# 1.0.0 – 2.3.0

## Introduction; Motor Basics

- The three basic types of motors are squirrel-cage induction motors, wound-rotor induction motors, and synchronous motors.
- **NEC Article 430** covers motor circuits and motor control connections, while **NEC Article 440** covers air conditioning and refrigeration equipment.

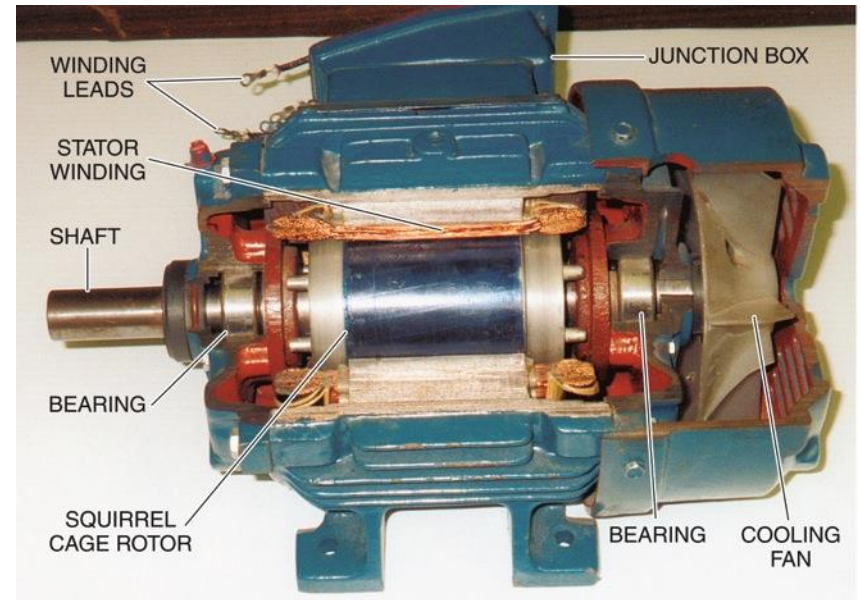

26309-14\_F01.EPS

## Squirrel Cage Rotor

- A squirrel-cage motor consists of steel laminations mounted on a frame (the stator) and a rotating shaft with embedded copper or aluminum windings (the rotor).
- When the stator is energized, a current is induced in the rotor. The speed at which the magnetic field rotates is known as the synchronous speed.

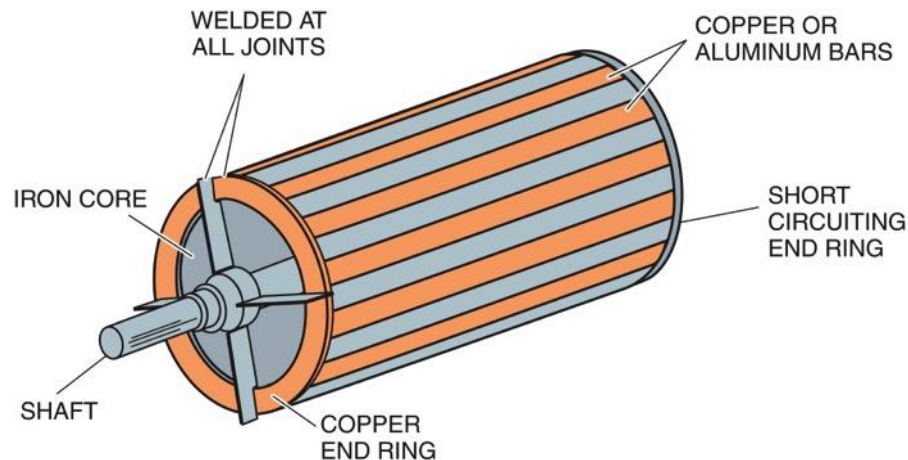

26309-14\_F02.EPS

## Types of Windings Found in Three-Phase Motors

- The stator windings of three-phase motors are connected in either a delta or a wye configuration.
- Some motors start in a wye configuration to reduce inrush current and then switch to a delta configuration when running.

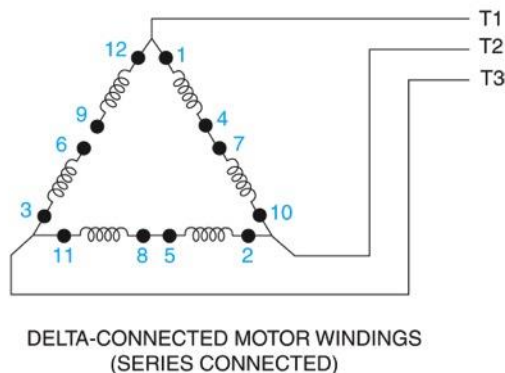
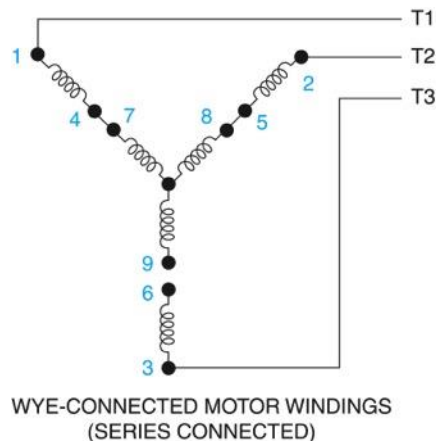

26309-14\_F03.EPS

# 1.0.0 – 2.3.0

## Dual Voltage, Wye-Connected, Three-Phase Motors

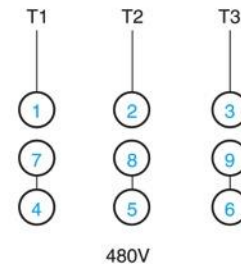
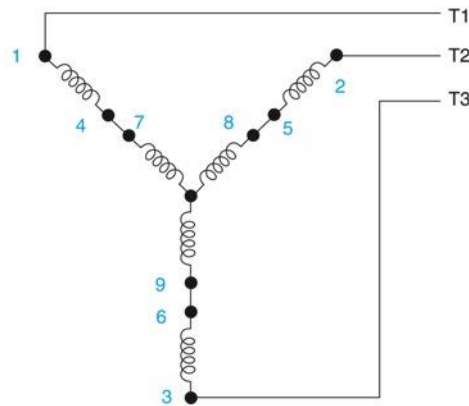

480V

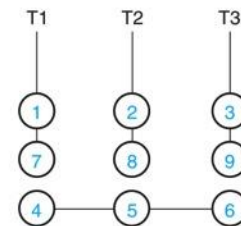
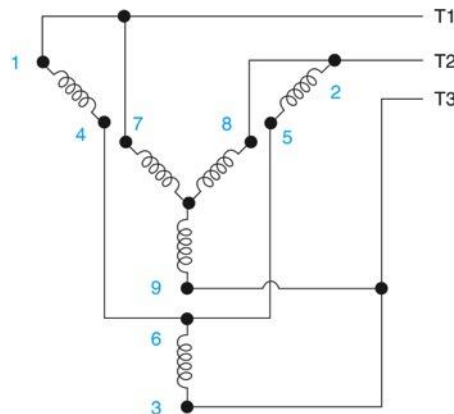

208/240V

26309-14\_F04.EPS



# 1.0.0 – 2.3.0

## Equivalent Parallel Circuit

- The leads are connected in series for the higher voltage and in parallel for the lower voltage.
- At the lower voltage, leads 4, 5, and 6 are connected together, as shown here.

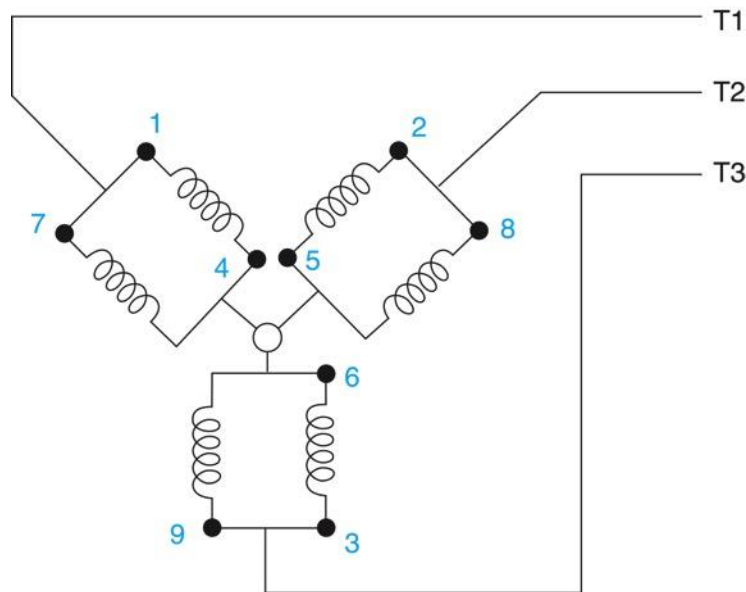

26309-14\_F05.EPS



# 1.0.0 – 2.3.0

## Arrangement of Leads in a Nine-Lead, Delta-Wound, Dual-Voltage Motor

Many delta-connected motors also have nine leads, but there are only three circuits of three leads each.

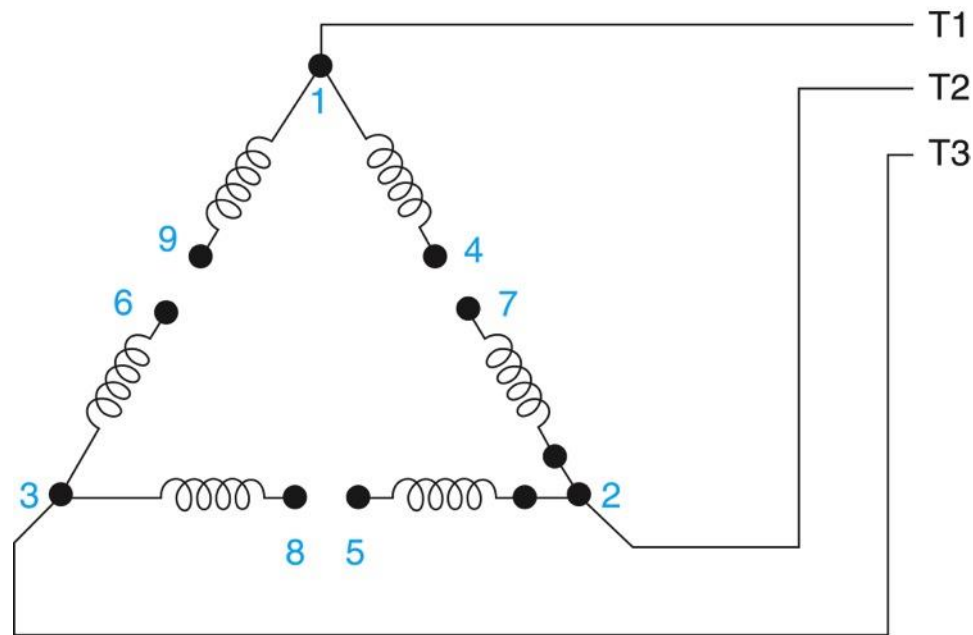

26309-14\_F06.EPS





# 1.0.0 – 2.3.0

## Lead Connections for a Three-Phase, Dual-Voltage, Delta-Wound Motor

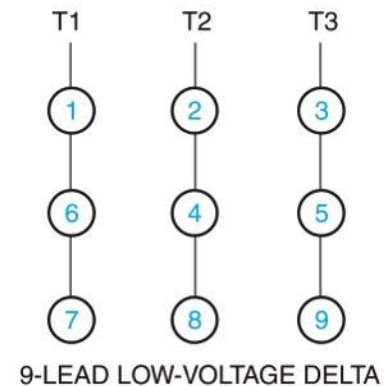
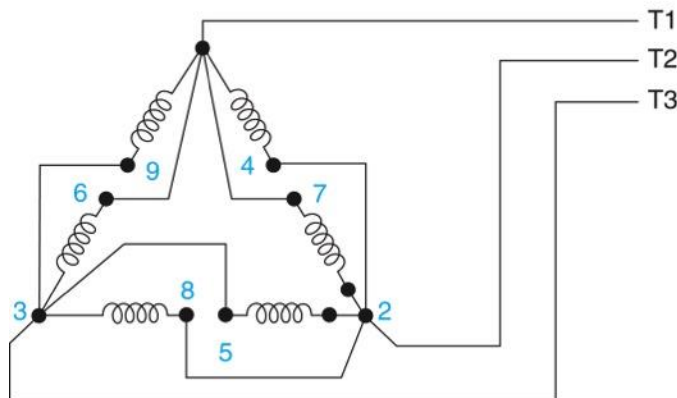
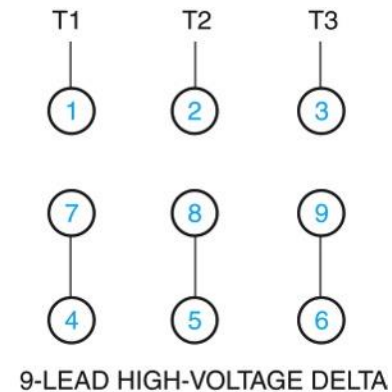
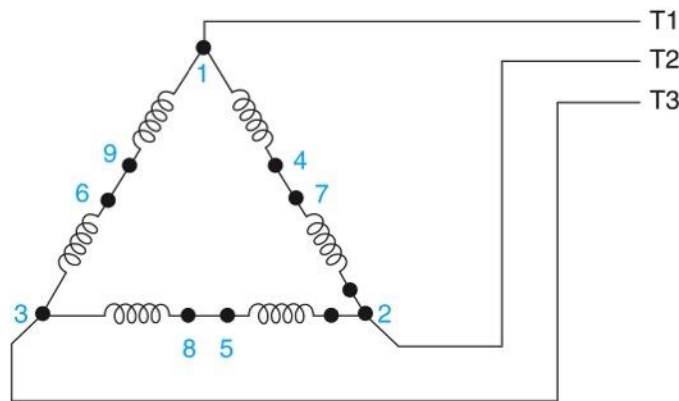

26309-14\_F07.EPS



# 1.0.0 – 2.3.0

## Lead Connections for a 12-Lead, Dual-Voltage, Delta-Wound Motor

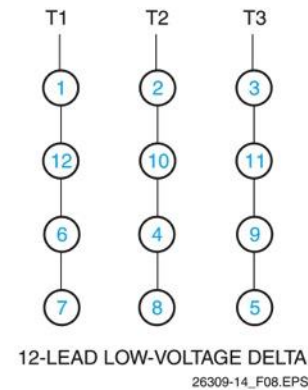
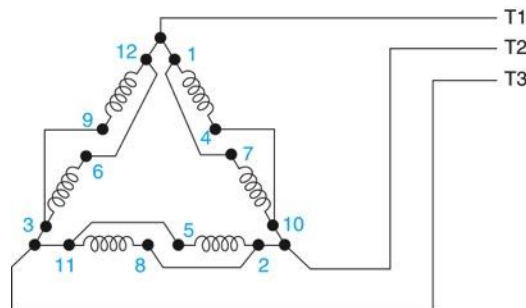
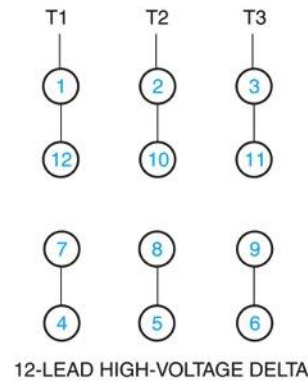
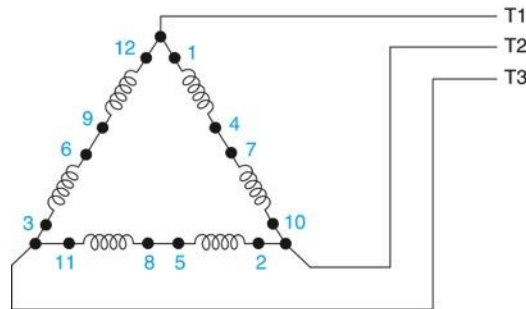

# 1.0.0 – 2.3.0

## Next Session... Fifteen-Lead Motor

- Some three-phase motors designed for operation above 600V have 15 or 18 leads.
- A 15-lead motor has three coils per phase, as shown here. Note that the leads are numbered in a spiral as with a nine-lead motor.

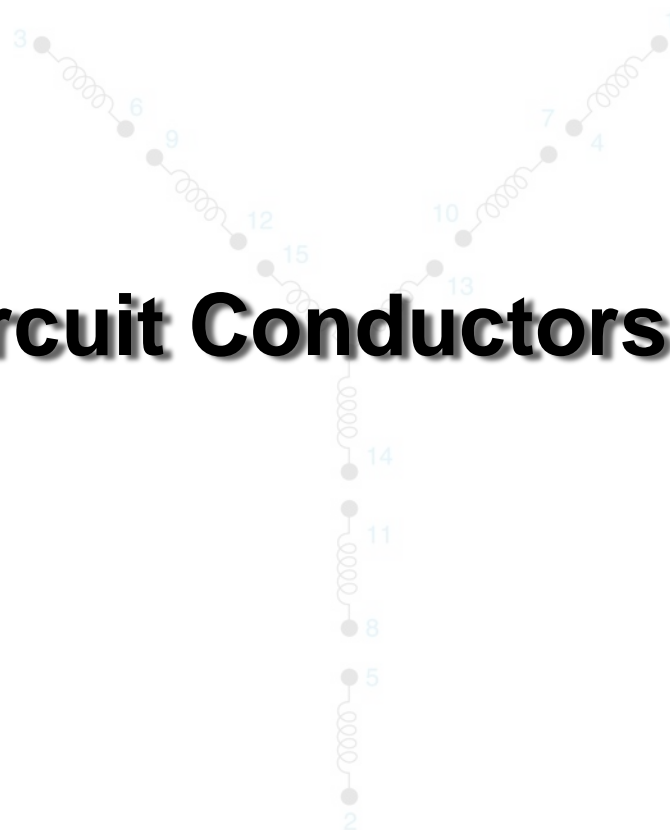

26309-14\_F09.EPS



## 3.0.0 – 3.3.0

# Calculating Motor Circuit Conductors

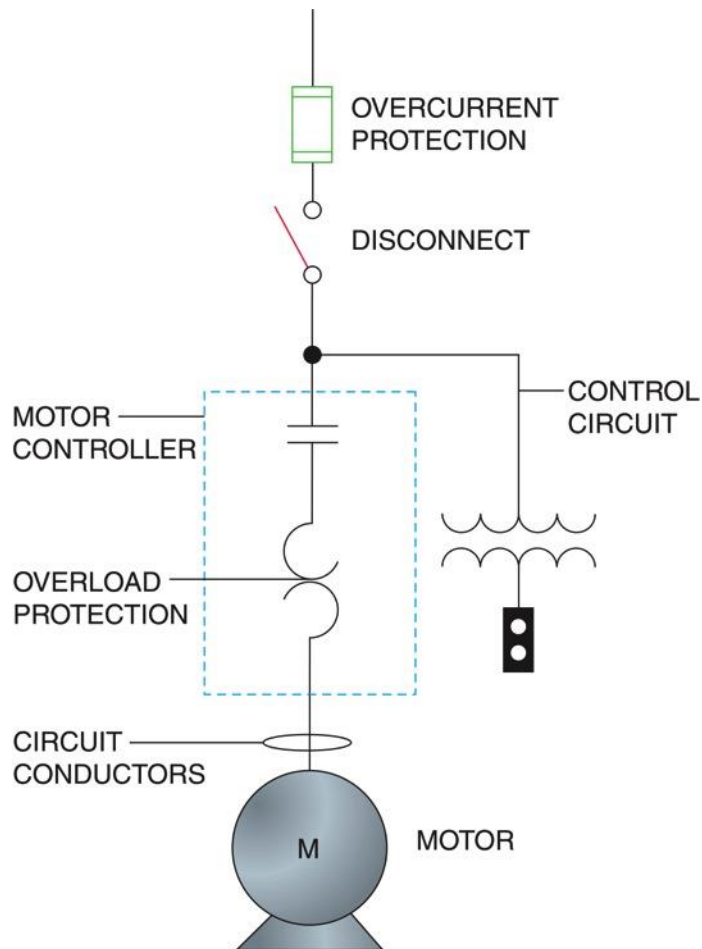

26309-14\_F10.EPS

- The basic components of a motor circuit include the circuit conductors, overload protection, motor controller, control circuit, disconnect switch, and overcurrent protection.
- In some cases, a switch can serve as both the control and the disconnect, or a fuse/circuit breaker can be used to provide both overload and overcurrent protection.

## 3.0.0 – 3.3.0

# Typical Motor Control Center

- To size the feeder conductors for more than one motor, find the full-load current of each motor in **NEC Table 430.250**, then multiply the value of the largest motor by 1.25 and add the sum of the remaining motors.
- The calculated amperage may have to be increased for the circuit voltage drop and/or power loss.

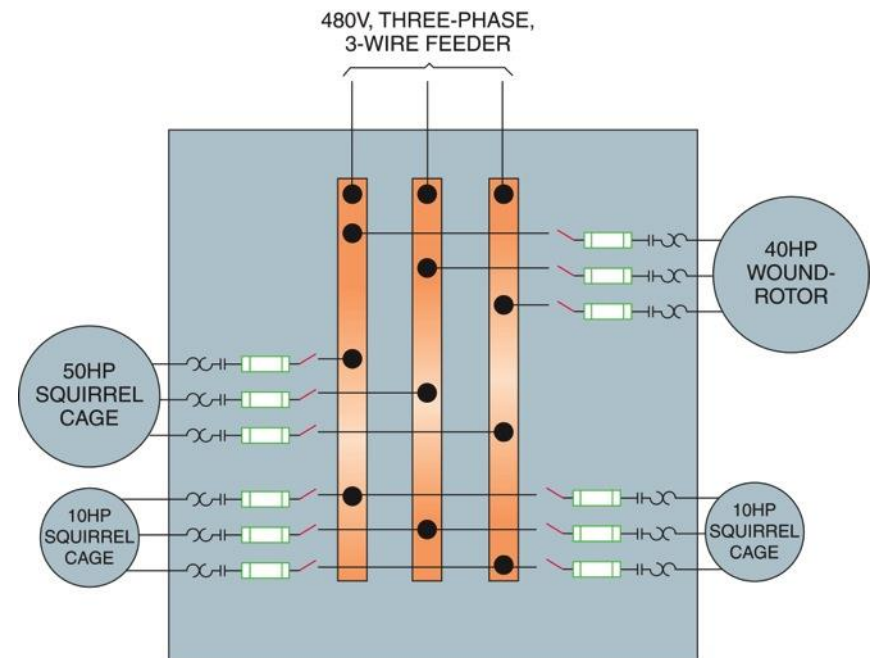

26309-14\_F11.EPS

# 3.0.0 – 3.3.0

## Next Session... Motor Branch Circuits

To size the branch circuit conductors feeding the individual motors, find the full-load current of each motor in *NEC Table 430.250*, then multiply the value of each motor by 1.25.

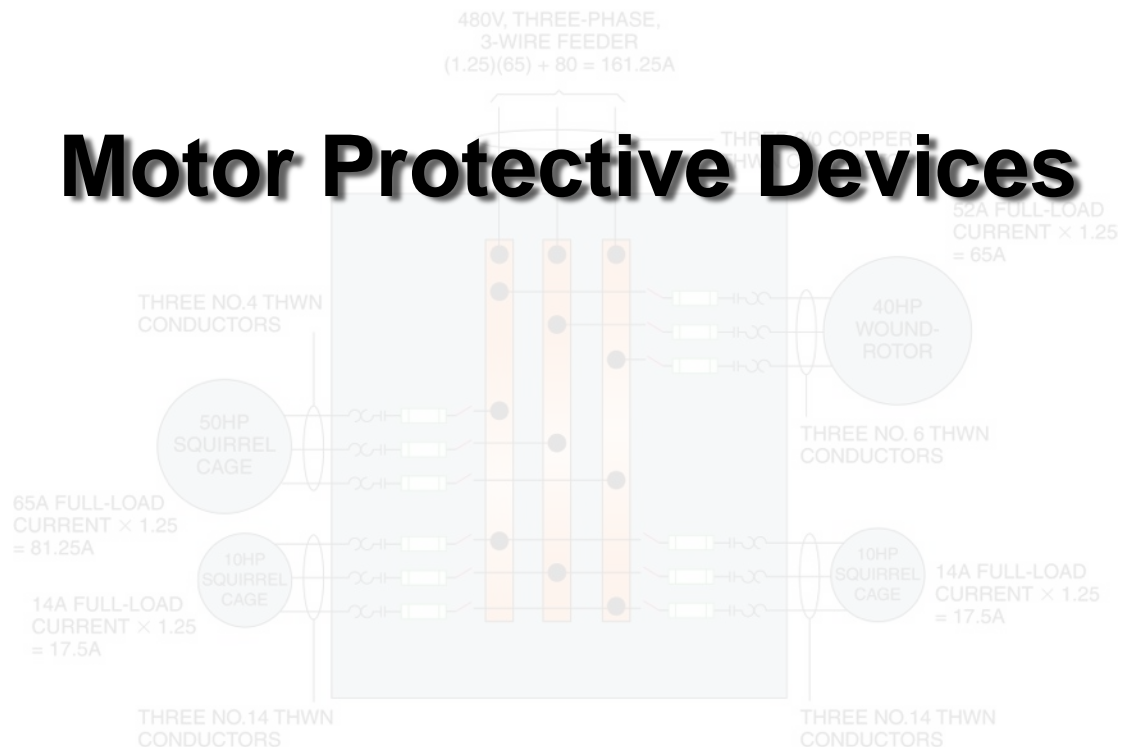

26309-14\_F12.EPS



# 4.0.0 – 4.2.0

## Motor Protective Devices

- Generally, two levels of overcurrent protection are required for motor circuits: overload protection and short circuit (including ground fault) protection.
- Ordinary motors must have short circuit/ground fault protection sized at 300% of the motor's full-load current, while DC and wound-rotor motors can have protection sized at 150%.

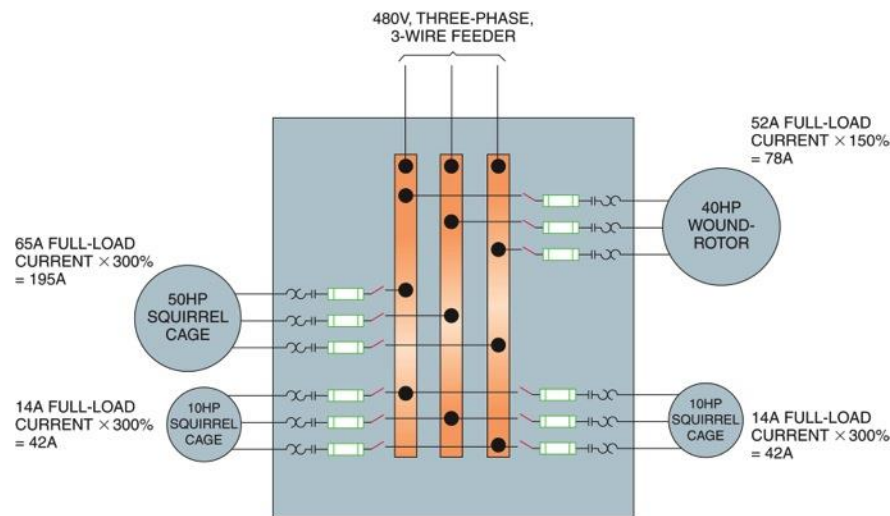

26309-14\_F13.EPS



# 4.0.0 – 4.2.0

## Fuse Application Guidelines for Motor Branch Circuits

Type of Motor	Dual-Element, Time-Delay Fuses			Nontime-Delay Fuses
	Motor Overload and Short Circuit	Backup Overload and Short Circuit	Short Circuit Only (Based on <i>NEC</i> Tables 430.247 through 430.250 current ratings)	Short Circuit Only (Based on <i>NEC</i> Tables 430.247 through 430.250 current ratings)
Service Factor 1.15 or Greater or 40°C Temp. Rise or Less	125% or less of motor nameplate current	125% or next standard size (not to exceed 140% of motor nameplate current)	150% to 175%	150% to 300%
Service Factor Less Than 1.15 or Greater Than 40°C Temp. Rise	115% or less of motor nameplate current	115% or next standard size (not to exceed 130% of motor nameplate current)	150% to 175%	150% to 300%

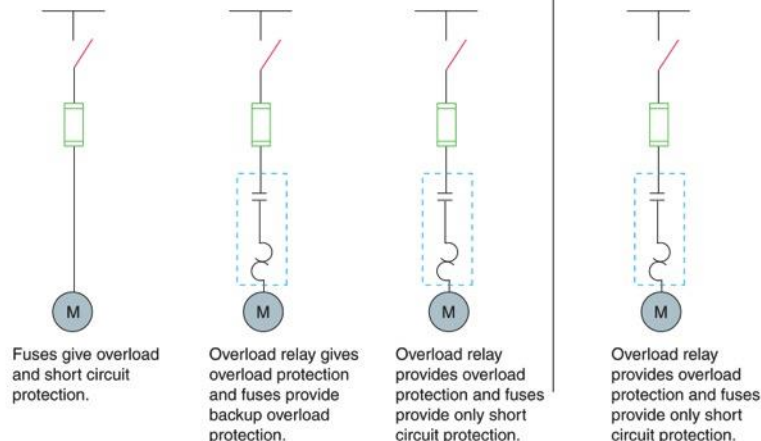

26309-14\_F14.EPS





## 4.0.0 – 4.2.0

# Determining Running Current With an Ammeter

- When supplying overcurrent protection for an existing oversized motor, determine the full-load running current of the motor using an ammeter.
- Size the overcurrent protection based on the measured current. Label the fuse clips with the fuse type and size for future replacements.

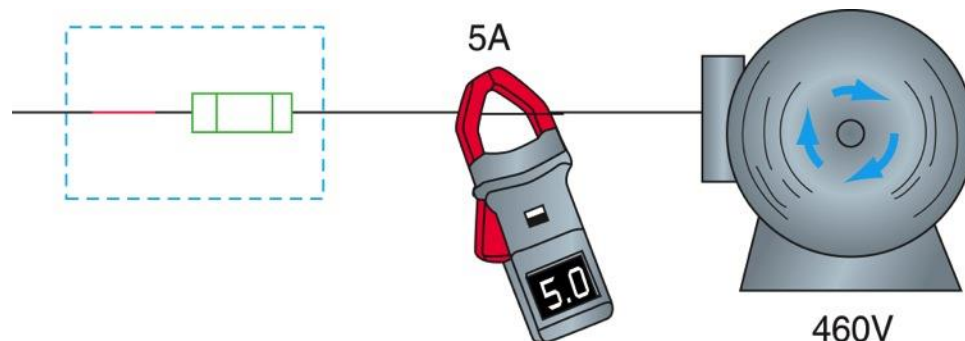

26309-14\_F15.EPS

## 4.0.0 – 4.2.0

# Motor Starting Current Characteristics

- The current of a motor during the first half cycle can be as much as 11 times higher than the motor's full-load amps (FLA).
- After the first half-cycle, the motor drops to the locked-rotor current and remains there for several seconds. It then drops to the motor FLA.

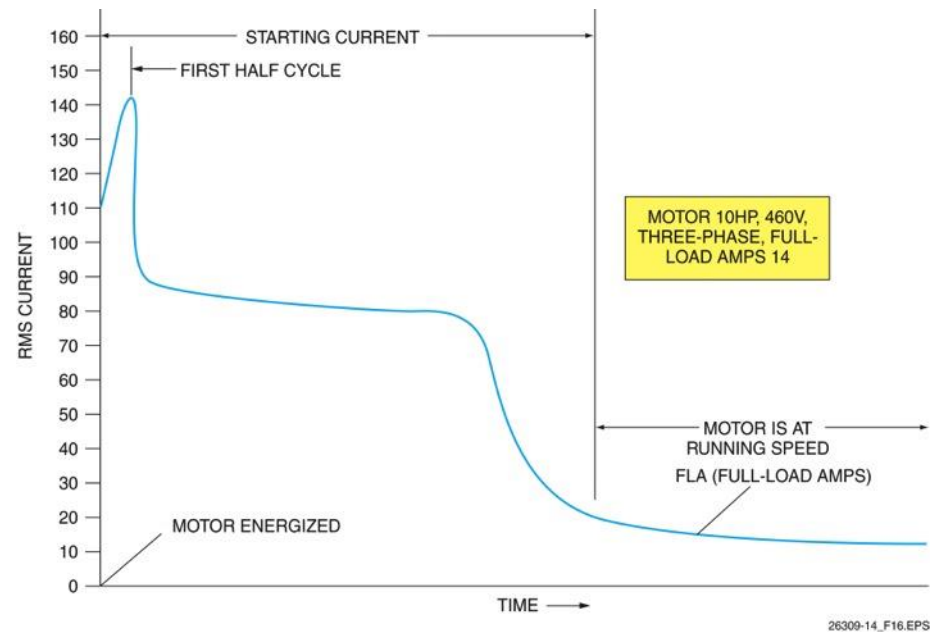

## 4.0.0 – 4.2.0

# Think About It – Overload Protection

In a 230V/460V motor such as the one shown here, which applied voltage requires the larger overload protection device?



26309-14\_SA01.EPS

## 4.0.0 – 4.2.0

# Time-Current Characteristics of Dual-Element Fuses and Overload Heaters

- The main types of devices used to provide motor overload protection include overload relays, fuses, and circuit breakers.
- Motor protective devices should have time-current characteristics similar to motor damage curves, only faster.

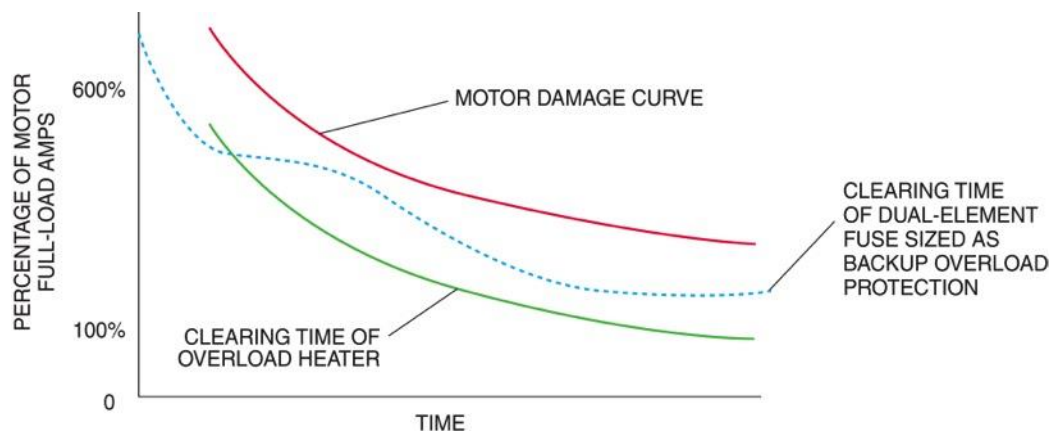

26309-14\_F17.EPS



## 4.0.0 – 4.2.0

# Circuit Components of a Typical 10-Horsepower Motor

- The overload relay is typically sized at 115% of the rated current.
- Dual-element fuses are sized at 125% for 1.15 service factor motors and 115% for 1.0 service factor motors.

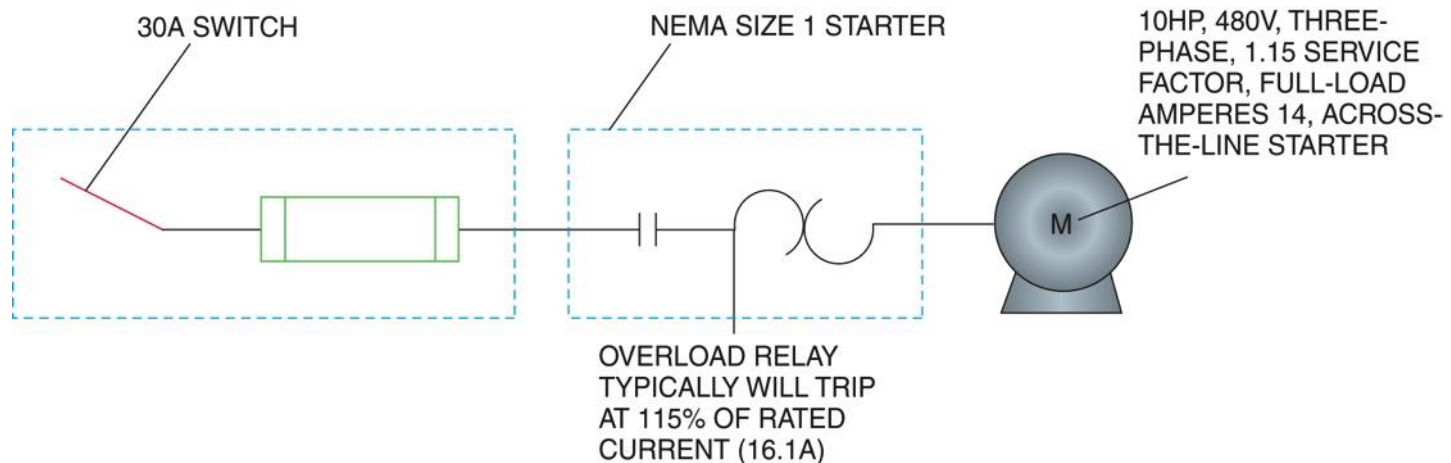

26309-14\_F18.EPS



## Circuit Breakers

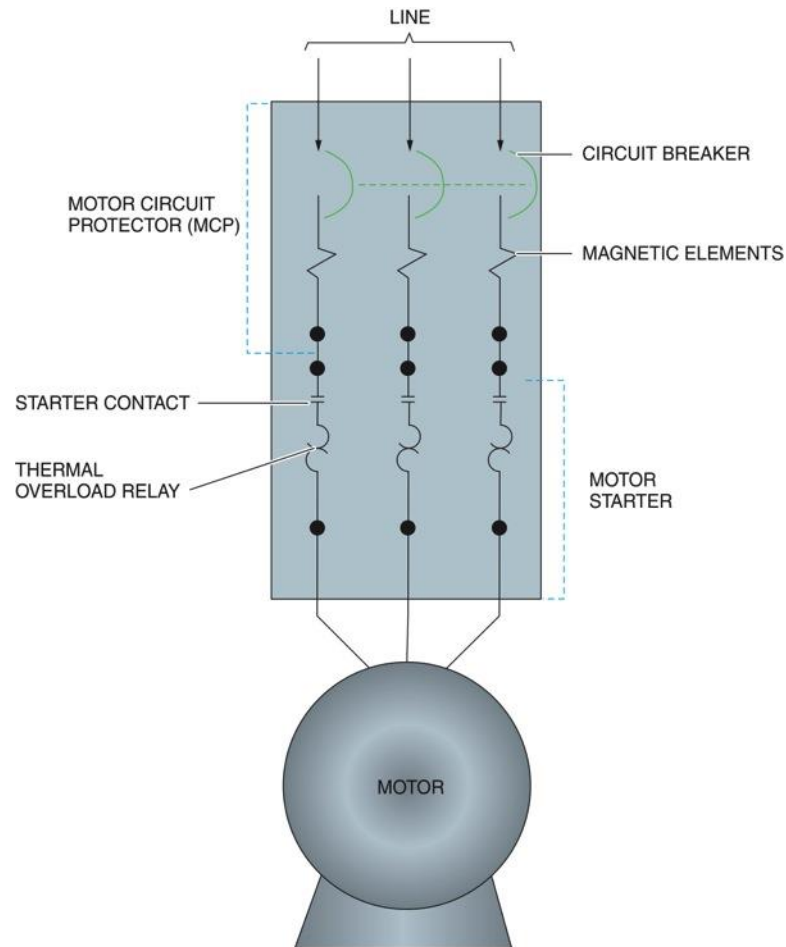

26309-14\_F19.EPS



# 5.0.0 – 5.2.0

## Next Session... 30-Horsepower Design B Energy-Efficient Motor Circuit

### Multi-Motor Branch Circuits; Equipment Grounding Conductors for Motor Feeder and Branch Circuits



26309-14\_F20.EPS



## 6.0.0 – 7.0.0

# Multi-Motor Branch Circuits; Equipment Grounding Conductors for Motor Feeder and Branch Circuits

- Two or more motors of no more than 6A each are permitted on a 20A branch circuit at 120V or a 15A branch circuit at 600V.
- Two or more motors of any rating with individual overload protection may be installed on a single branch circuit that is protected by a motor short circuit protective device (MSCP).

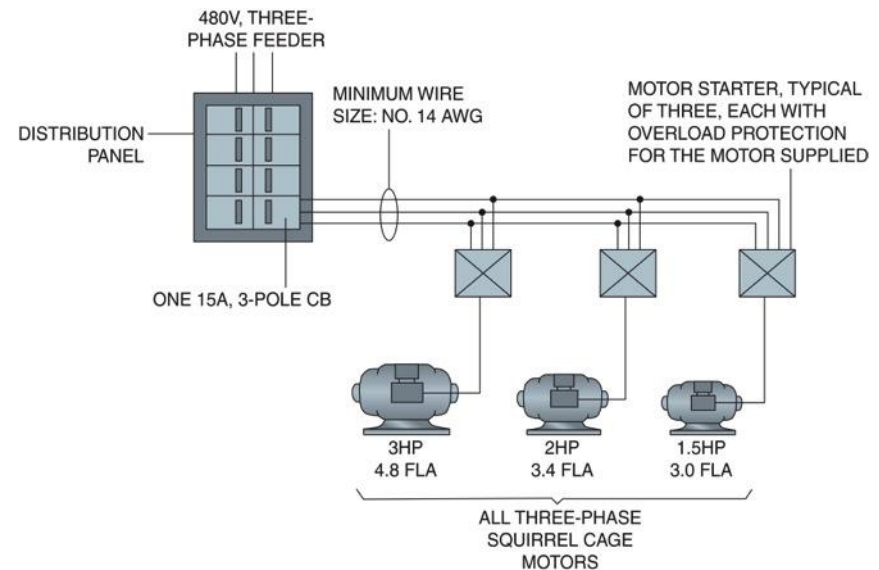

26309-14\_F21.EPS



## 6.0.0 – 7.0.0

# Several Smaller Motors Supplied by One Branch Circuit

- **NEC Section 430.53(B)** requires branch circuit protection to be no greater than the maximum amperes permitted by **NEC Section 430.52** for the lowest rated motor of the group.
- Per **NEC Table 430.52**, the maximum protection rating for a circuit breaker is 250% of the lowest rated motor (in this case,  $2.5 \times 1.1\text{A} = 2.75\text{A}$ ).

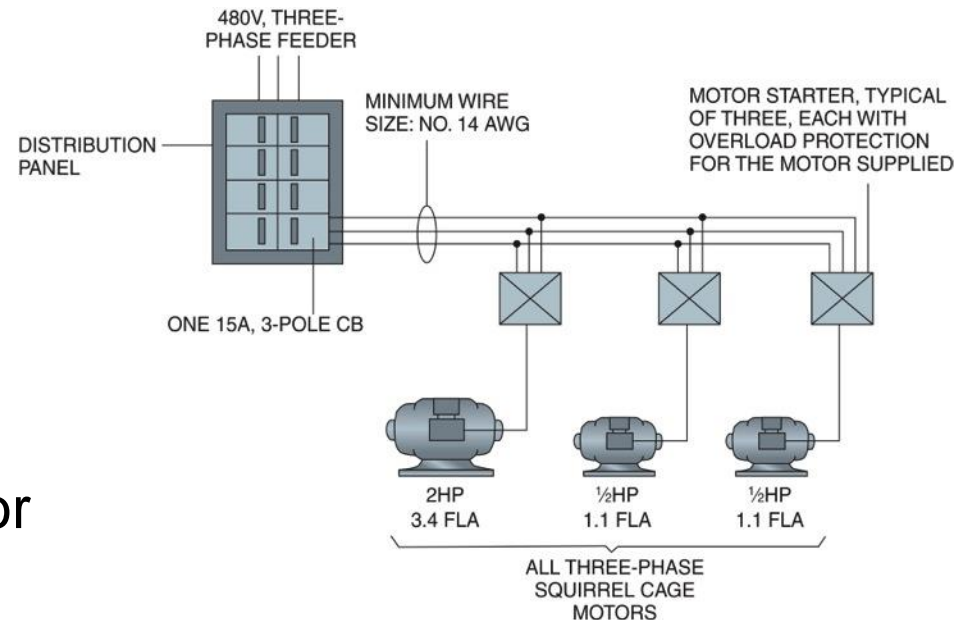

26309-14\_F22.EPS



## 8.0.0

# Power Factor Correction at Motor Terminals

- Power factor correction can be provided by installing capacitors at the induction motor.
- Ideally, capacitors should be installed between the overload device and the disconnect (Point 2 on the diagram shown here). Capacitors located at Point 3 will require a change in overload protection.

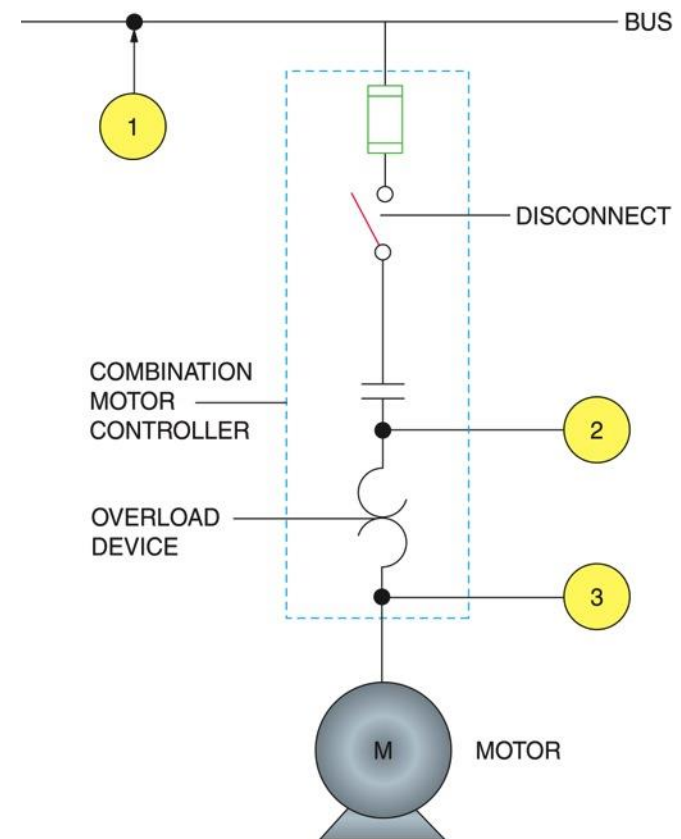

26309-14\_F23.EPS

# 8.0.0

## Next Session... Power Factor Correction Table

Nominal Motor Speed in RPM																
3600			1800			1200			900			720			600	
Induction Motor Horsepower Rating	Capacitor Rating kVAR	Line Current Reduction %	Capacitor Rating kVAR	Line Current Reduction %	Capacitor Rating kVAR	Line Current Reduction %	Capacitor Rating kVAR	Line Current Reduction %	Capacitor Rating kVAR	Line Current Reduction %	Capacitor Rating kVAR	Line Current Reduction %	Capacitor Rating kVAR	Line Current Reduction %		
3	1.5	14	1.5	15	1.5	20	2	27	2.5	35	3.5	41				
5	2	12	2	13	2	17	3	25	4	32	4.5	37				
7.5	2.5	11	2.5	12	3	15	4	22	5.5	30	6	34				
10	3	10	3	11	3.5	14	5	21	6.5	27	7.5	31				
15	4	9	4	10	4.5	13	6	19	8	23	9.5	27				
20	5	9	5	10	5.5	12	7	18	9	21	12	25				
25	6	9	6	10	6.5	11	8	17	11	20	14	23				
30	7	8	7	9	7.5	10	9	16	12	18	16	22				
40	9	8	9	9	9	10	11	15	15	16	20	20				
50	12	8	11	9	11	10	13	13	19	15	24	19				
60	14	8	14	8	13	10	15	12	22	15	27	19				
75	17	8	16	8	15	10	18	11	26	14	32.5	18				
100	22	8	21	8	18	10	25	10	32.5	13	40	17				
125	27	8	26	8	21	9	30	10	40	13	47.5	16				
150	32.5	8	30	8	24	9	35	10	47.5	12	52.5	15				
200	40	8	37.5	8	28	9	42.5	10	60	12	65	14				
250	50	8	45	7	35	8	52.5	9	70	11	77.5	13				

**Wrap Up**



# Wrap Up

## 3-2-1

- 3 – Write 3 important things learned during class
- 2 – Write 2 questions you have about the material
- 1 – Write 1 thought you had about the material



# Next Session...

## MODULE EXAM

Review the complete module to prepare for the module exam. Complete the Module Review as a study aid.

