

Electrical Level 3



Practical Applications of Lighting 26303-14



Objectives

When trainees have completed this lesson, they should be able to do the following:

1. Explain how the lighting terms *lumen*, *candlepower*, and *footcandle* relate to one another.
2. Classify lighting fixtures by type and application.
3. Identify the general lighting pattern produced by each type of fixture.
4. Identify the lighting requirements associated with lighting systems used in selected applications such as office buildings, schools, theaters, hazardous areas, etc.
5. Identify various dimming systems and their components.
6. Use manufacturers' lighting fixture catalogs to select the appropriate lighting fixtures for specific lighting applications.



Performance Tasks

1. Using manufacturers' catalogs, select the appropriate lighting fixtures for specific lighting situations.
2. While touring selected structures to observe their lighting systems:
 - Identify the various types of lighting fixtures used.
 - Explain the specific purpose(s) served by the different fixtures.
 - Identify the lighting system class of service.



Introduction; Lumens, Candlepower, and Footcandles

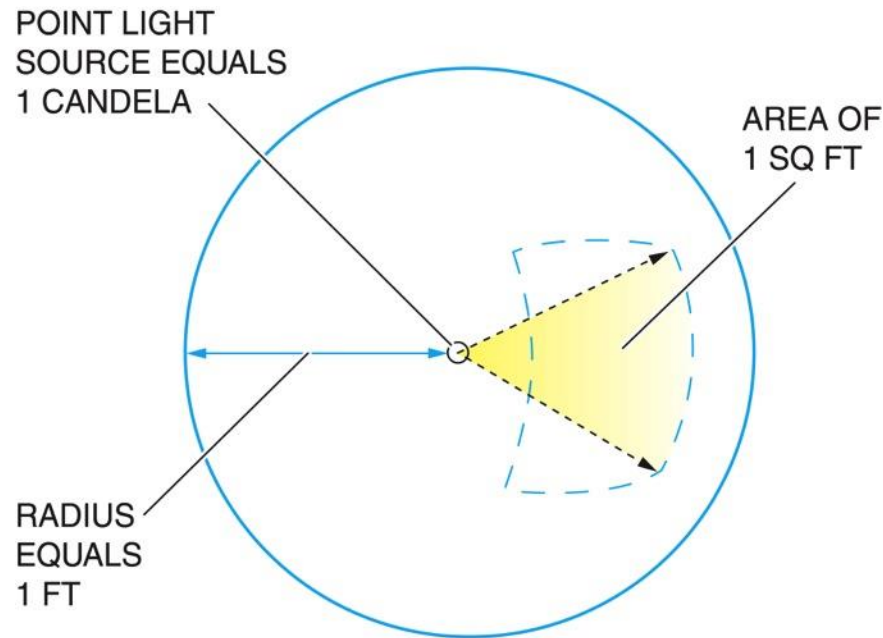

One lumen equals the amount of light cast upon one square foot of the inner surface of a hollow sphere of one-foot radius when a light source of one candela is placed at the center of the sphere.

1.0.0 – 2.0.0

Definition of One Footcandle

- The terms *footcandle* and *candlepower* are often confused. The footcandle (fc) is used to measure illuminance, or the total amount of light per unit area.
- Candlepower (cp) measures the intensity of a light source in a given direction.

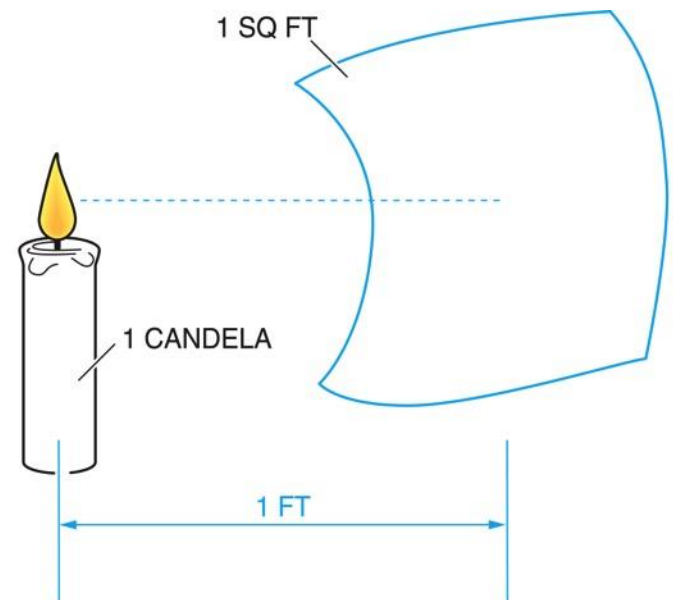

One lumen falling on one square foot of surface illuminates the surface to an intensity of one footcandle.

26303-14_F02.EPS

3.0.0 – 3.3.0

Classification of Lighting Fixtures

- Lighting can be classified by layout and location, luminaire types, and type of service.
- Classification by layout and location includes: general and localized general lighting, local lighting, task lighting, accent (directional) lighting, wall wash, and egress (exit) lighting.

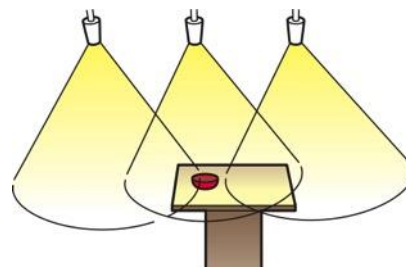

(A) GENERAL

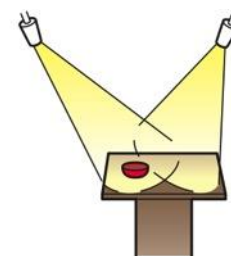

(B) TASK

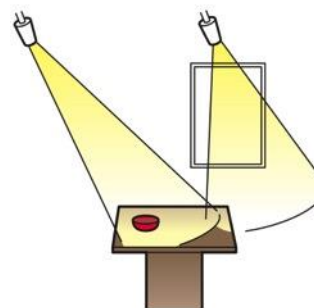

(C) ACCENT

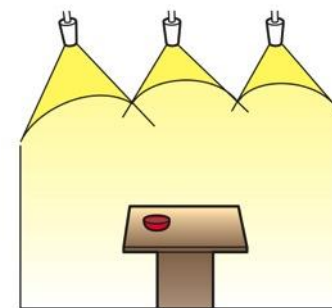

(D) WALL WASH

26303-14_F03.EPS

3.0.0 – 3.3.0

Next Session...

CIE Classifications of Lighting Fixtures

(A) DIRECT

0-10%
90-100%

(B) SEMI-DIRECT

10-40%
60-90%

Practical Applications of Lighting Fixtures

(C) GENERAL DIFFUSE

40-60%
40-60%

(D) DIRECT-INDIRECT

40-60%
40-60%

(E) SEMI-INDIRECT

60-90%
10-40%

(F) INDIRECT

90-100%
0-10%

- The Commission Internationale de l'Eclairage (CIE) classifies luminaires for general lighting by the percentage of light emitted above and below the horizontal plane.
- Lighting is also classified by type of service: industrial, commercial, residential, street lighting, and security/floodlighting.

26303-14_F04.EPS



4.0.0 – 4.1.4

Practical Applications of Lighting Fixtures



DIFFUSED FIXTURES



DOWNLIGHTS

- Incandescent fixtures are used mainly in indoor residential and commercial lighting applications.
- Since incandescent bulbs were phased out of production in January 2014, the lamps in these fixtures are being replaced with compact fluorescent bulbs.
- Ceiling-mounted fixtures with diffusers are used for general lighting. Ceiling-mounted downlights provide accent lighting or task illumination.

26303-14_F05.EPS

4.0.0 – 4.1.4

Incandescent Wall-Mounted Fixtures



- Incandescent wall fixtures provide either diffused or directional lighting.
- Wall-mounted downlights are used to provide accent and/or display lighting, while uplights provide indirect light. Sconces are used in hallways or stairways as accent lights.

26303-14_F06.EPS

4.0.0 – 4.1.4

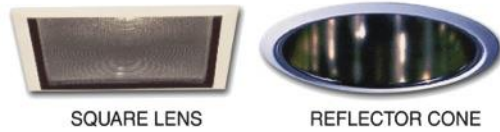

PULL-DOWN ADJUSTABLE

(A) STANDARD DOWNLIGHTS

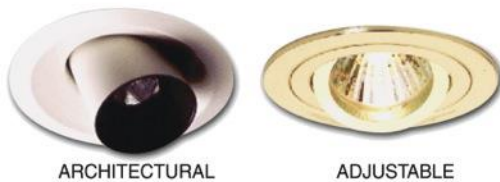

PINHOLE APERTURE

(B) LOW-VOLTAGE DOWNLIGHTS

26303-14_F07.EPS

Recessed Incandescent Downlights (Below Ceiling View)

- Recessed incandescent downlights provide lighting without the intrusion of a fixture and are often used in room with low ceilings.
- Recessed fixtures can provide general lighting, accent or task lighting, and wall washing.

4.0.0 – 4.1.4

Recessed Incandescent Downlights (Outline Views)

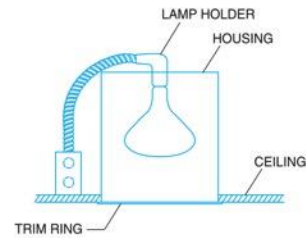

(A) CAN

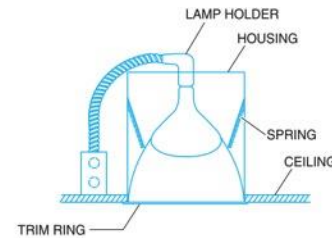

(B) PARABOLIC REFLECTOR

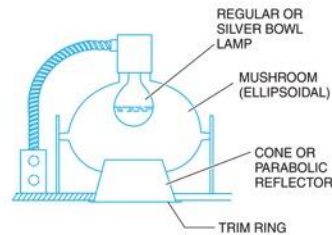

(C) ELLIPSOIDAL REFLECTOR

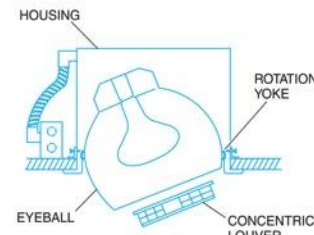

(D) RECESSED EYEBALL

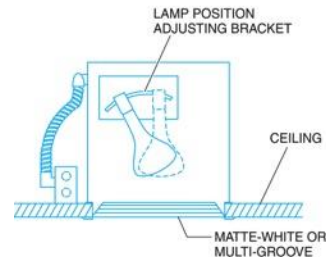

(E) DIRECTIONAL

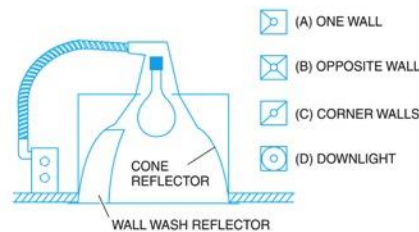

(F) MOVABLE WALL WASHER

26303-14_F08.EPS



4.0.0 – 4.1.4

Typical Commercial/ Residential Suspended Incandescent Lighting Fixtures



26303-14_F09.EPS

- Suspended fixtures are hung by a chain, aircraft wire, cord, conduit, or stem and include diffusers where the fixture is in the occupant's line of sight.
- Suspended fixtures are typically used to provide decorative or accent lighting. Fixtures hung above a dining table are normally positioned 30" to 32" above the table to prevent glare.

4.0.0 – 4.1.4

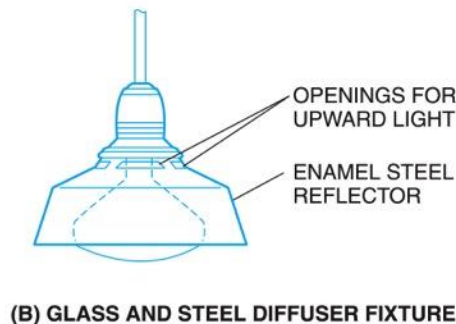
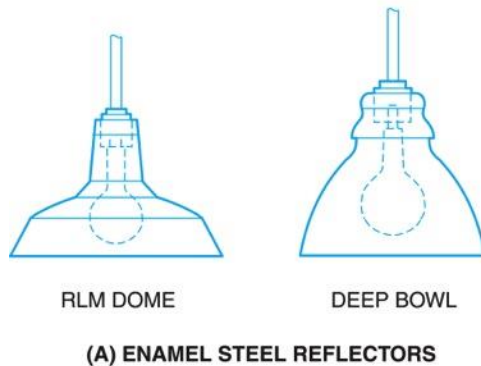
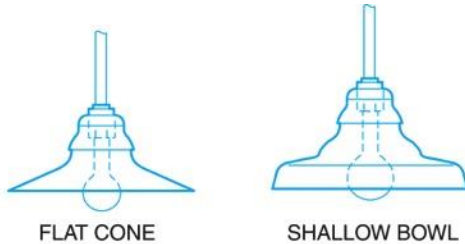

26303-14_F10.EPS

Incandescent Suspended Lighting Fixtures

Suspended incandescent fixtures equipped with enamel or steel reflectors are typically used in commercial applications.

4.0.0 – 4.1.4

Typical Incandescent Track Lighting Fixtures



- Track lighting allows light to be directed as desired for general lighting, accent lighting, task lighting, and wall washing.
- Track fixtures rotate and also provide horizontal adjustment to achieve the desired effect.

26303-14_F11.EPS

4.2.0 – 4.2.2



FRAMED



WRAPAROUND



SOFT CLOUD



DOME



UNDER CABINET



SHALLOW MUSHROOM

26303-14_F12.EPS

Fluorescent Lighting Fixtures

- Fluorescent fixtures are available for use in surface-mounted, suspended, and recessed fixtures, and can be used to provide general, accent, and task lighting.
- These fixtures are typically provided with white acrylic diffusers and use circline or compact fluorescent lamps.

4.2.0 – 4.2.2

Surface/Suspension-Mounted Fluorescent Lighting Fixtures

- Some fluorescent fixtures are designed so that they may be either surface-mounted or pendant-mounted.
- Strip or channel fixtures are typically used in storage rooms and warehouses, while the others are used where aesthetics are more important, such as offices, factories, schools, and retail stores.



(A) STRIP OR CHANNEL



(B) WRAPAROUND



(C) TASK AREA



(D) COMMERCIAL INDUSTRIAL
4-LAMP T-5HO FIXTURE



(E) COMMERCIAL INDUSTRIAL
8-LAMP T-8 FIXTURE

26303-14_F13.EPS

4.2.0 – 4.2.2

Recessed Troffers

- Recessed troffers are used to provide uniform general lighting over specific task/work areas.
- These square or rectangular fixtures can be installed in the recesses above plaster, drywall, or suspended ceilings.



2 × 4 LENSED TROFFER



2 × 2 PARABOLIC



4" × 4" PARABOLIC
STRETTO



2 × 4 PARABOLIC

26303-14_F14.EPS

4.3.0

High-Intensity Discharge (HID) Lighting Fixtures

- High-bay and low-bay high-intensity discharge (HID) fixtures are used extensively in industrial applications.
- High-bay fixtures deliver focused light onto the work plane, while low-bay fixtures deliver more evenly spaced light.

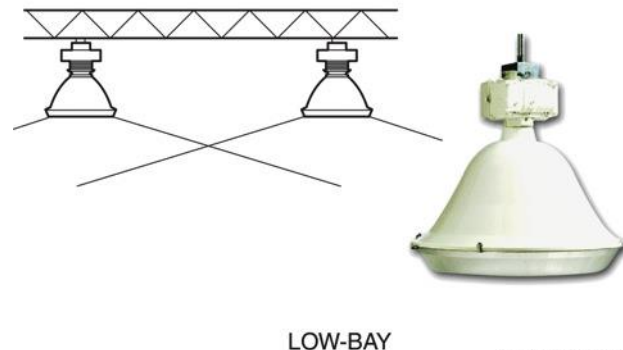
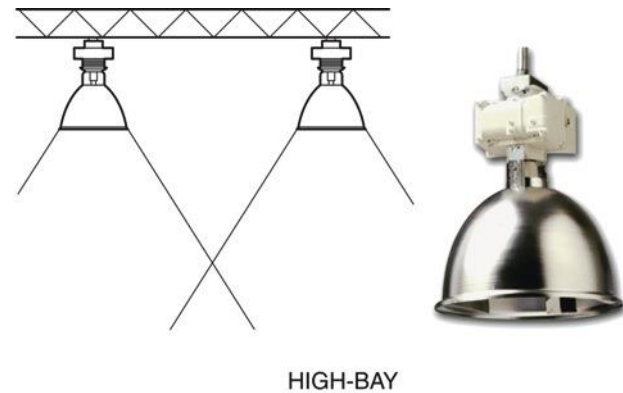

26303-14_F15.EPS

4.4.0

Outdoor Lighting Fixtures

- Because of their efficiency and long life, HID fixtures are commonly used in outdoor lighting applications.
- Most of these fixtures use high-pressure sodium or metal halide lamps.

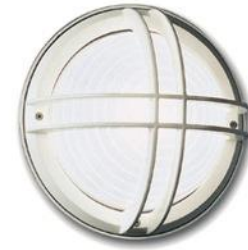

WALL MOUNT



PARKING GARAGE

26303-14_F16.EPS

4.4.0

Pole-Mounted and Other Outdoor Fixtures

- Pole-mounted fixtures are used for roadway and parking lot lighting. They supply light in wide distribution patterns in order to permit greater spacing between poles.
- Walkways are frequently illuminated using bollard fixtures.
- Floodlights and spotlights are used for both sporting events and to illuminate building facades.



26303-14_F17.EPS

4.5.0

Emergency and Exit Lighting Fixtures

- Emergency lights provide illumination in hallways, stairways, and at exits.
- This type of fixture charges a battery when AC power is applied and transfers battery power to the fixture in the event of a power loss.



26303-14_F18.EPS

4.6.0

Induction Lighting Systems

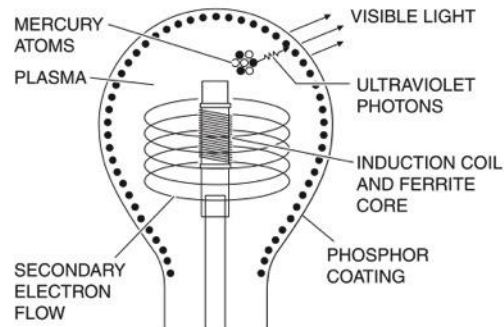

(A) QL DISCHARGE PRINCIPLE

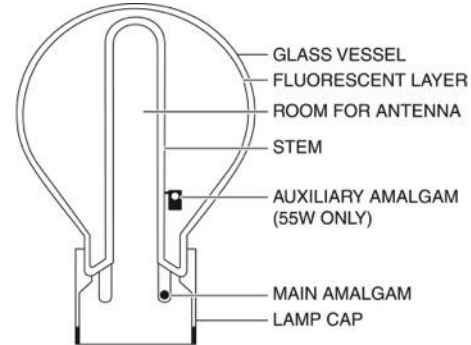

(B) VESSEL CROSS SECTION

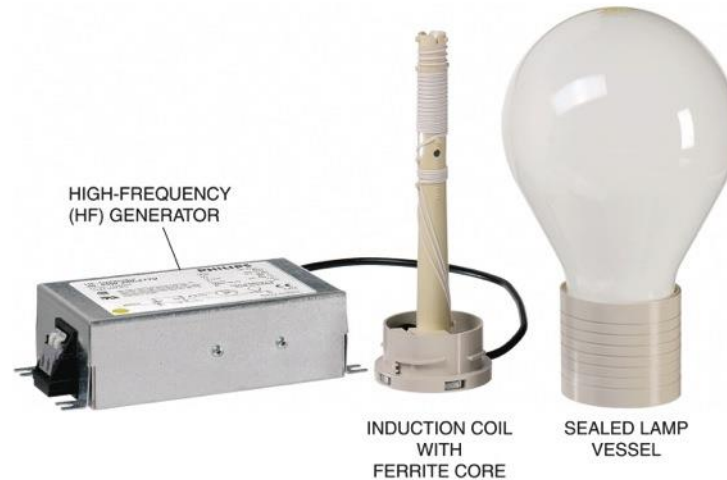

(C) QL SYSTEM COMPONENTS

26303-14_F19.EPS



4.6.0

ICETRON® Induction Lighting System

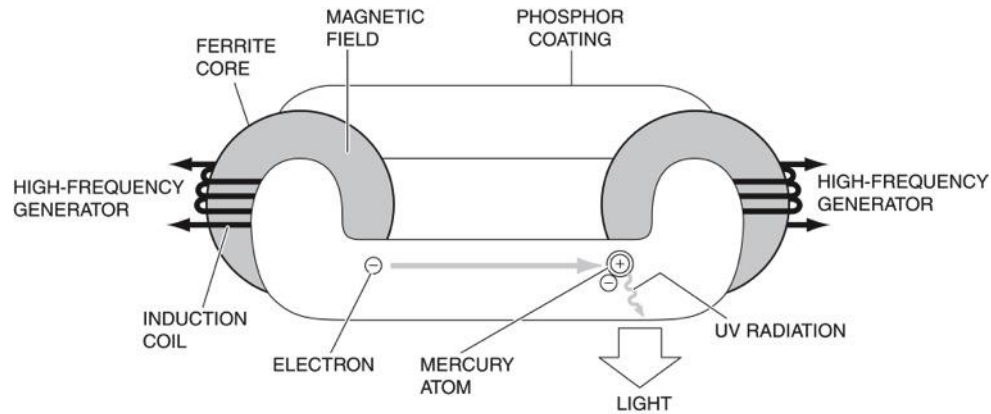

(A) ICETRON® DISCHARGE PRINCIPLE



(B) ICETRON® SYSTEM COMPONENTS

26303-14_F20.EPS



4.6.0

QL and ICETRON® Induction Lighting System Applications



(A) ICETRON® STREET, WALKWAY,
OR PARKING LOT FIXTURE



(B) ICETRON® POST-TOP
FIXTURE



(C) QL PARKING GARAGE
FIXTURE



(D) ICETRON® WALL-MOUNTED FIXTURE



(E) QL LOW-BAY FIXTURES

26303-14_F21.EPS

4.7.0 – 4.7.2

Light-Emitting Diode (LED) Technology

- Light-emitting diode (LED) fixtures provide high-intensity lighting with minimal power use and long service life.
- LEDs are now widely used for traffic lights, exit lighting, step lighting, video displays, accent lighting, and many other applications.



(A) LARGE RGB VIDEO DISPLAY



(B) TRAFFIC SIGNAL



(C) EXIT AND EMERGENCY LIGHTING



(D) PATH AND STAIR STEP LIGHTING

26303-14_F22.EPS

4.7.0 – 4.7.2

Individual Color-Changing LED Lamps

- Color-changing LEDs can be used for architectural and special-effects lighting systems.
- Some types require the use of special drivers or sequencers, while other are self-contained and do not require a digital controller.



(A) RGB 30° SELF-CONTAINED LAMPS



(B) RGB 30° AND 60° SELF-CONTAINED LAMPS

26303-14_F23.EPS

4.7.0 – 4.7.2

Individual Fixed-Color LED Lamps

Fixed-color LEDs are designed for use in existing fixtures and can be used to replace incandescent lamps.



LED FLAME TIP BULB



LED G25 GLOBE BULB



G11 GLOBE BULBS

26303-14_F24.EPS

4.7.0 – 4.7.2

Edge-Lit LED Cove Lighting

Solid-state lighting (SSL) is the newest generation of LED technology and provides high-brightness and ultra high-brightness downlighting for a variety of applications, including the retail store lighting shown here.



26303-14_F25.EPS

4.7.0 – 4.7.2

RFI-Free LED Ceiling Lighting Fixtures

- This radio frequency interference (RFI)-free lighting is ideal for use in magnetic resonance imaging (MRI) suites.
- In addition to not interfering with the operation of the equipment, it provides a soothing view for patient relaxation.



LUMINOUS SKYCEILING WITH RFI-FREE LED LIGHTING
OVER MRI MACHINE



LED TROFFER

26303-14_F26.EPS

4.7.0 – 4.7.2

Low-Bay LED Lighting Fixture

- Low-bay LED lighting fixtures are available for a variety of commercial applications.
- Each fixture provides 2,500 lumens with a power consumption of only 75W. Larger versions are available for use in streetlights.



26303-14_F27.EPS

4.7.0 – 4.7.2

LED Streetlights



26303-14_F28.EPS



4.8.0

Hazardous and Adverse Location Lighting Fixtures

- Lighting fixtures used in hazardous (classified) locations are completely enclosed to protect against sparks, flashes, and explosions.
- **NEC Article 500** covers the requirements for hazardous locations.



WARNING LIGHTS



LIGHTING FIXTURE

26303-14_F29.EPS

4.9.0 – 4.10.0

Next Session... Vandal-Resistant Lighting Fixtures; Lighting Fixture Illumination Control

- Vandal-resistant lighting fixtures are designed for use in unsupervised public areas.
- These heavy-duty fixtures feature impact-resistant lenses and/or guards and tamperproof hardware.

Special-Purpose Wiring Systems Used for Lighting

Performance Task

This session will conclude with trainees using manufacturers' catalogs to select the appropriate lighting fixtures for specific lighting situations.



26303-14_F30.EPS



6.0.0 – 6.1.0

Special-Purpose Wiring Systems Used for Lighting

- Special-purpose wiring systems include manufactured system wiring, lighting trolley busways, and strut-type channel systems.
- Manufactured system wiring uses a feeder adapter and wiring components with special connectors to add fixtures to the circuit without the need for additional hard wiring.

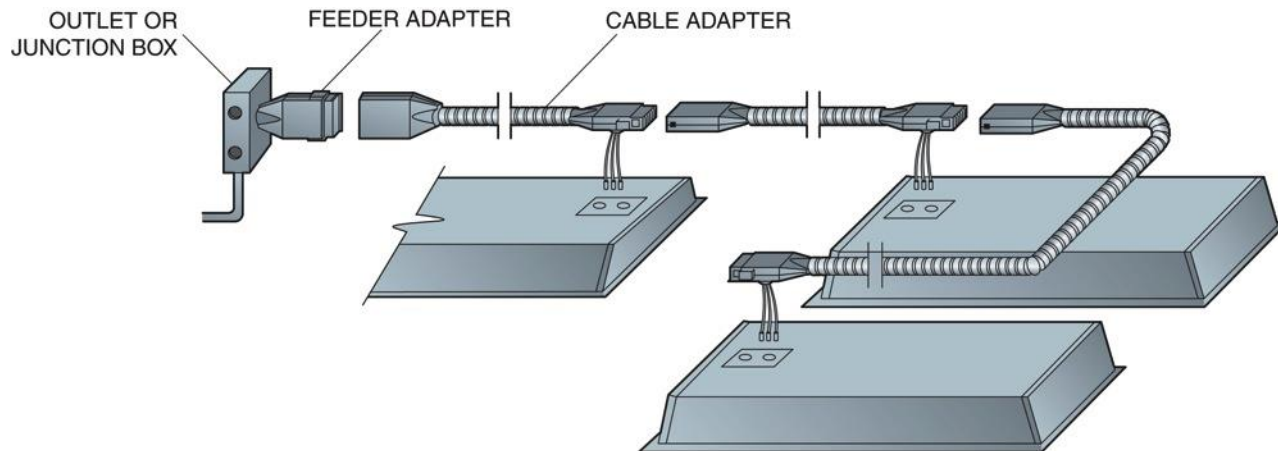

26303-14_F31.EPS

6.2.0

Lighting Trolley Busways

- Lighting trolley busways provide flexibility similar to track lighting.
- Fixtures can easily be positioned as desired along the busway and additional trolleys added or removed as desired.

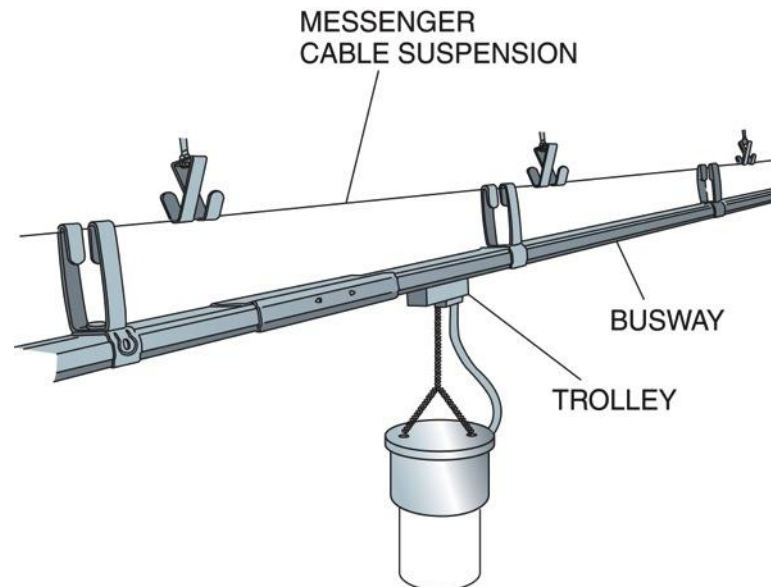

26303-14_F32.EPS



6.3.0

Strut-Type Channel Systems

- Strut-type channel systems provide both fixture support and wiring, and are used in commercial and industrial applications.
- The hardware and hangers vary by manufacturer.

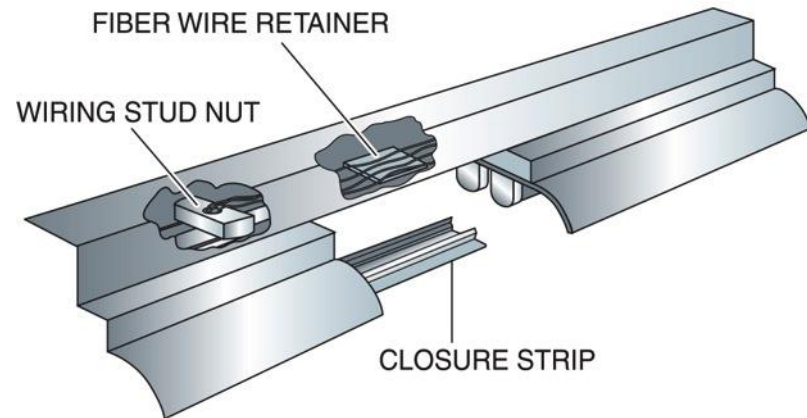
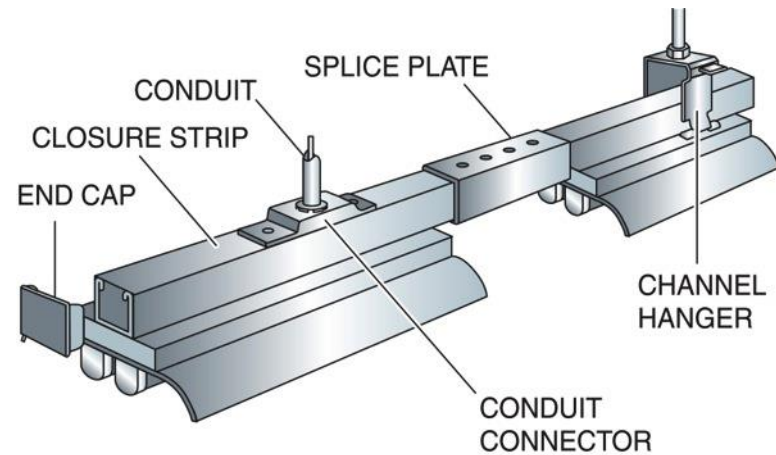

26303-14_F33.EPS



7.0.0 – 7.1.0

Dimming

- Dimmers can be used both to control lighting for mood and to preserve energy.
- Incandescent and tungsten halogen lighting fixtures can be dimmed by reducing the voltage across the filament. Either autotransformer-type or solid state dimmer controls can be used.

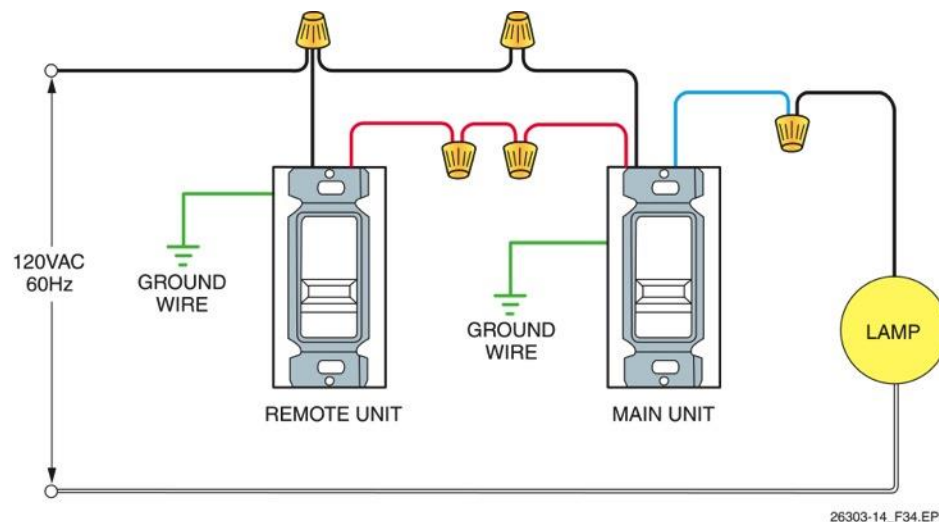

7.2.0

Fluorescent Lamps

- Special dimming ballasts and controls are required when dimming fluorescent fixtures. Fluorescent fixtures cannot be dimmed down to zero like incandescent and tungsten halogen types.
- Most dimmer ballasts use solid-state circuitry to provide a low-level signal to the dimming control to regulate the lamp's current and output.

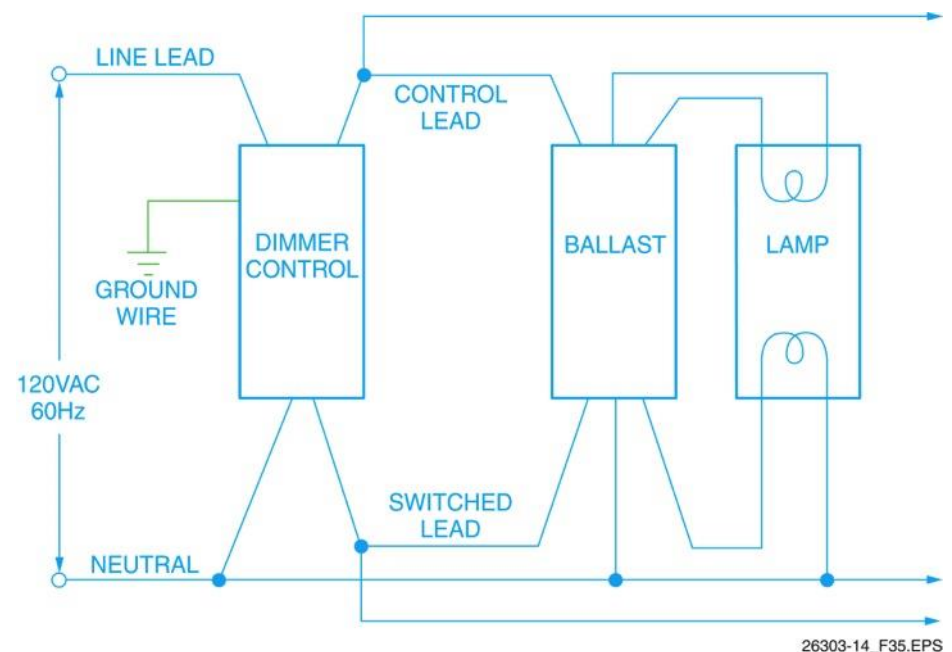

7.2.0

Basic Control Circuit to Control Dimming of Multiple Fluorescent Fixtures

- Energy-management systems can be connected to control multiple fluorescent dimming fixtures.
- Follow the manufacturer's instructions for burn-in when installing dimmable fluorescent fixtures.

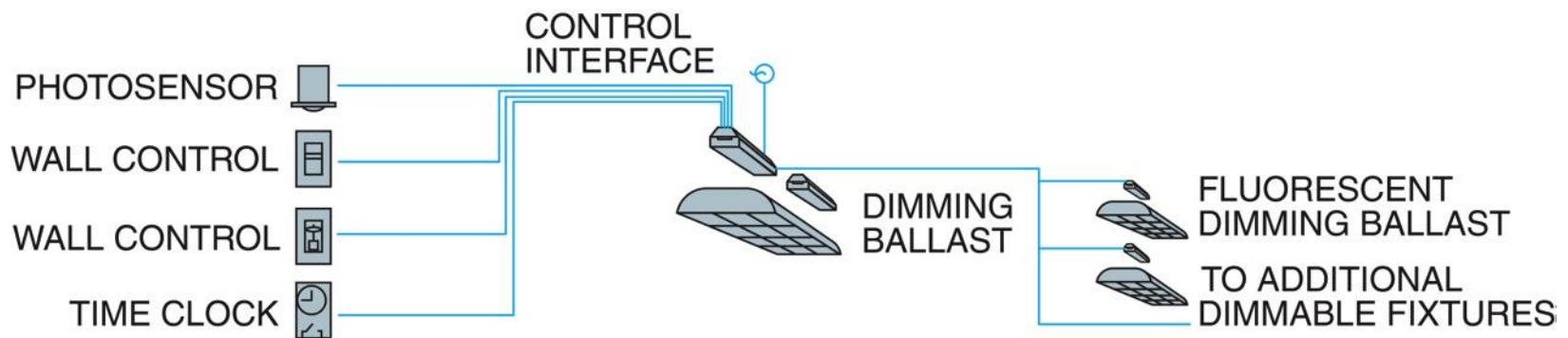

26303-14_F36.EPS

7.3.0

HID Lamps

- HID fixtures operate best at full power but can be dimmed for energy conservation if necessary.
- HID lamps respond much slower to dimming operations than incandescent or fluorescent types.

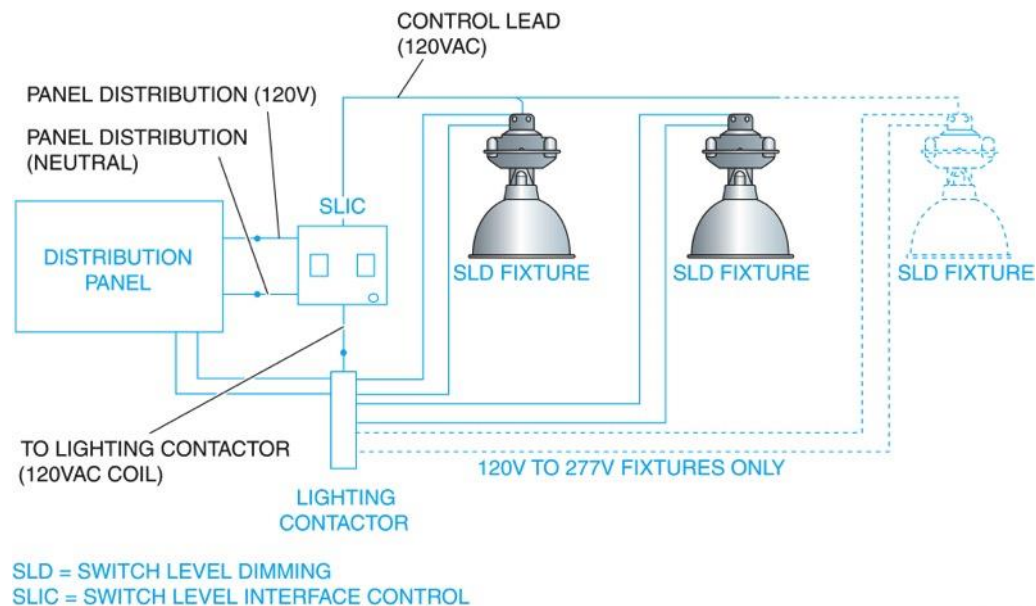

26303-14_F37.EPS



7.3.0

Simplified Automatic HID Light Dimming System

- The HID circuit shown here allows for zone control of HID fixtures.
- It also includes an occupancy detector that increases illumination when it senses the presence of an occupant and reduces it for energy conservation when the occupant leaves.

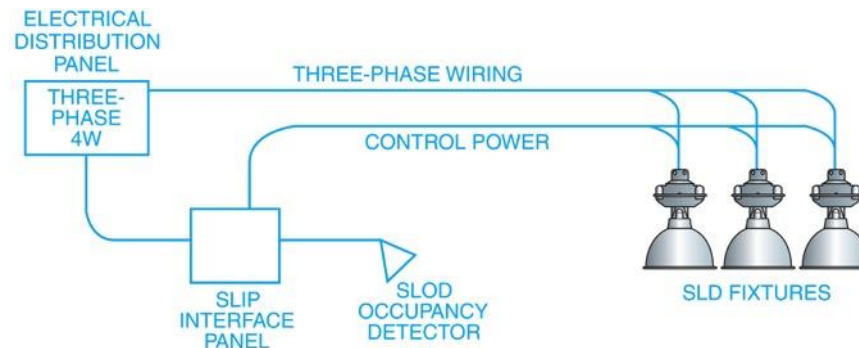

SLIP = SWITCH LEVEL INTERFACE PANEL
SLOD = SWITCH LEVEL OCCUPANCY DETECTOR
SLD = SWITCH LEVEL DIMMING

26303-14_F38.EPS

7.4.0

Next Session... Dimmer Control Racks

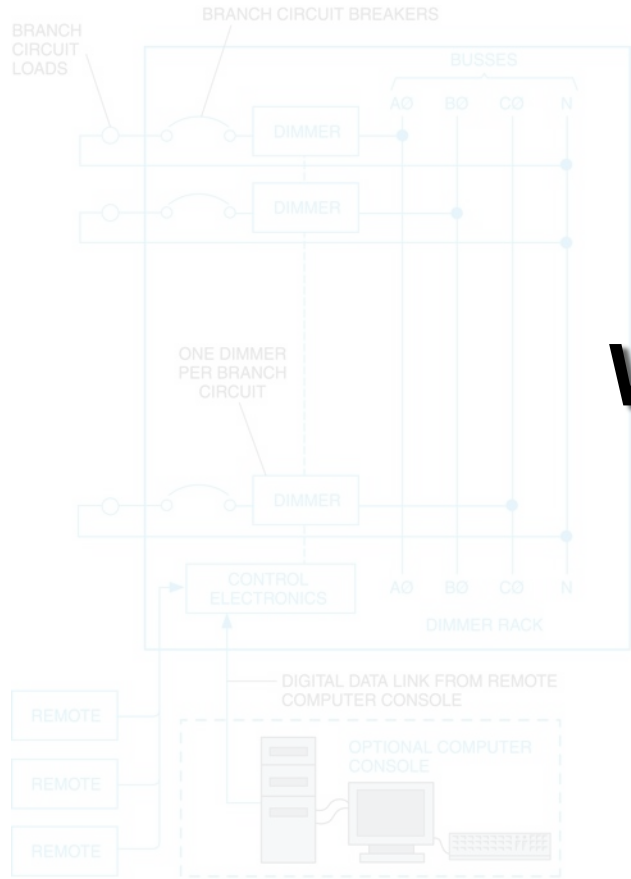

Wrap Up

Performance Task

This session will conclude with trainees touring selected structures to observe their lighting systems and identifying the various types of lighting fixtures used, the specific purposes(s) served by the different fixtures, and identifying the lighting system class of service.

26303-14_F39.EPS



Wrap Up

3-2-1

- 3 – Write 3 important things learned during class
- 2 – Write 2 questions you have about the material
- 1 – Write 1 thought you had about the material



Next Session...

MODULE EXAM

Review the complete module to prepare for the module exam. Complete the Module Review as a study aid.

