

2

1

B

B

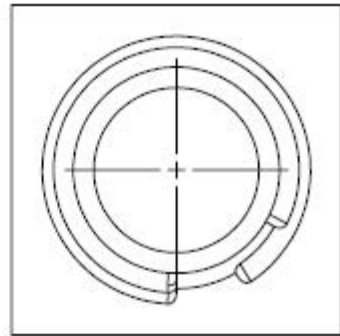
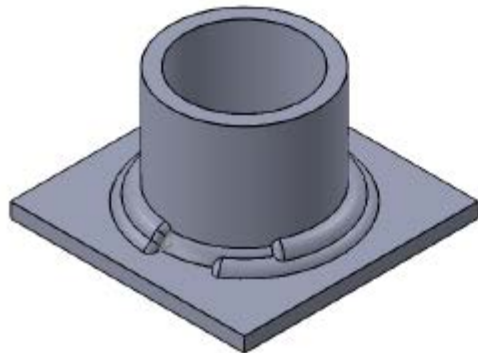

A

A

PROCESS:	GMAW
ELECTRODE CLASSIFICATION:	E70S-6
ELECTRODE SIZE:	.035"
POSITION:	2F
WELD SIZE/ # OF BEADS:	6
AMPERAGE/WFS:	100-250
VOLTAGE:	18-22

ROOT FACE:	
ROOT OPENING:	

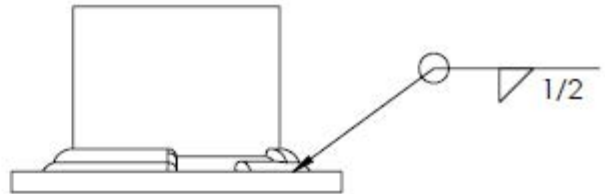

TITLE: Pipe to Plate		
SIZE A	DWG. NO.	REV
SCALE: 1:2	SHEET 1 OF 1	

DIMENSIONS ARE IN INCHES
TOLERANCES:
FRACTIONAL: ±
ANGULAR: MACH ± BEND ±
TWO PLACE DECIMAL ±
THREE PLACE DECIMAL ±

2

1

